

## Standard Features – Beer Dispenser Model #ADD-60

- Holds (2) ½ kegs
- Double tap towers
- Includes 4 "D" system keg couplers
- Foamed-in-place polyurethane insulation
- (4) epoxy-coated shelf
- Environmentally-safe R290 refrigerant
- LED lights illuminate interior
- (2) locking self-closing door with recessed handles
- 115V; 1/5 HP
- ETL listed. Conforms to UL STD. 471, Certified to CSA STD. C22. 2No.120
- Conforms to NSF/ANSI STD. 7

## Construction

Exterior Material	Black Coated Steel
Interior Material	Painted aluminum
Insulation Material	Foamed-In-Place Polyurethane
Shelf	(4) 23-5/8 x 18-1/8 epoxy-coated steel
Taps	(4) 10-1/4 faucet height

## Dimensions

Exterior Dimensions	60-3/4"W x 24-3/8"D x 35-5/8"H
Interior Dimensions	48-1/4"W x 18-1/2"D x 28-7/8"H
Shipping Dimensions	51-1/4"W x 27-1/2"D x 41-3/4"H
Tower Dimensions	16" H 3" Diameter
Net Volume	17.3 cu. ft.
Net Weight	276 lb.
Gross Weight	319 lb.

## Model #ADD-60

### Cooling

Temperature Range	33°F-40°F
Refrigerant	R290
Max. Ambient Temperature	90°F
Defrosting	Automatic
Temperature Controller	Digital
Horsepower	1/5

### Electrical

Voltage	115
Amps	3
Hz	60
Phase	1
Plug Type	NEMA-5-15P
Electrical Cord Length	96"



Parts & Labor

Compressor

## PLAN VIEW

Front View

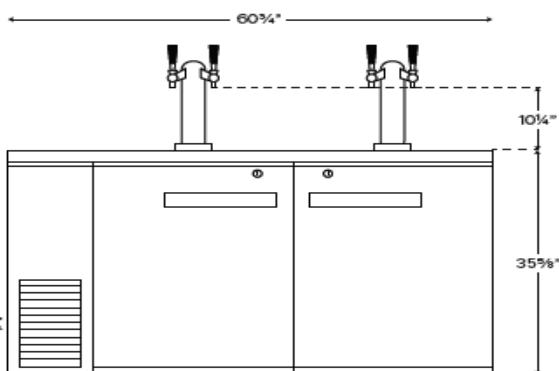

Side View

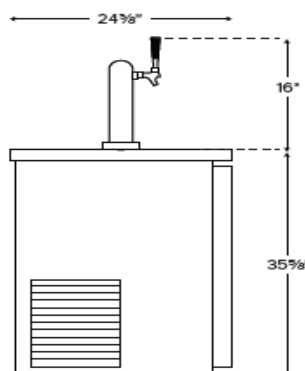

Top View

