



Model #AMC-49

Cooling

Temperature Range	33°F-40°F
Refrigerant	R290
Max. Ambient Temperature	90°F
Defrosting	Automatic
Temperature Controller	Digital
Horsepower	1/5

Electrical

Voltage	115
Amps	2.88
Hz	60
Phase	1
Plug Type	NEMA-5-15P
Electrical Cord Length	96"

Standard Features – Cold Wall Milk Cooler (12 Crate)

- Environmentally safe R290 refrigerant
- White powder coated steel exterior
- Painted aluminum interior
- Holds up to 12 milk crates
- Cold wall refrigeration system
- Foamed-in-place insulation
- Fold down door with flip top lid
- 18.5 Cu. Ft. interior
- Digital temperature controller
- 115V; 1/5 HP
- ETL listed. Conforms to UL STD. 471, Certified to CSA STD. C22. 2No.120
- Conforms to NSF/ANSI STD. 7

Construction

Exterior Material	Powder Coated
Interior Material	Painted aluminum
Insulation Material	Foamed-In-Place Polyurethane

Dimensions

Exterior Dimensions	49W x 30-5/8"D x 41-3/8"H
Interior Dimensions	45-7/8"W x 27"D x 25-3/4"H
Shipping Dimensions	50-1/4"W x 31-1/4"D x 45-1/4"H
Net Volume	18.5 cu. ft.
Net Weight	243 lb.
Gross Weight	275 lb.



Parts & Labor

Compressor

PLAN VIEW

Front View

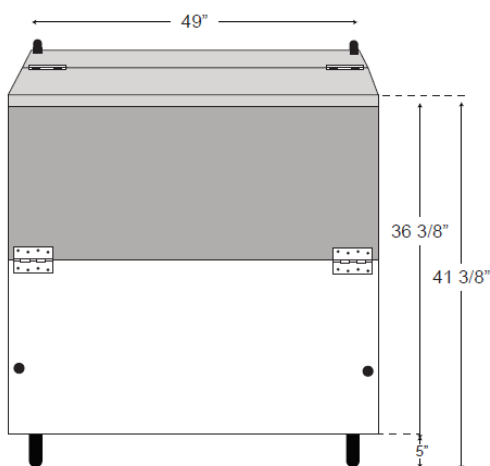

Side View

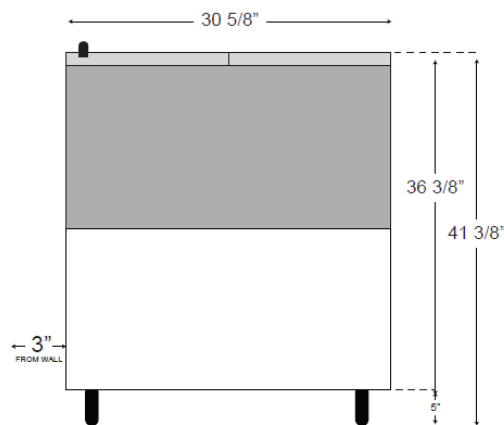

Top View

