



FR FOOD RETHERMALIZERS / BAIN-MARIE HEATERS

Models FR-3, FR-4, FR-6, FR-9, FR-3B, FR-4B, FR-6B, FR-9B

The Hatco FR is designed to be used with a Bain-Marie or food reconstitutor, to heat or hold foods at safe temperatures between 140°F and 190°F (60°-88°C).

FLEXIBILITY

The FR mounts easily to the underside of a holding vessel, leaving the entire vessel area free. Water is continually circulated to avoid any "cool" spots. The unit controls water temperature from 140°F (60°C) to 190°F (88°C).

The Hatco FR is shipped factory assembled, pre-wired, and includes standard 2" (51 mm) plated brass plumbing fittings for mounting into a holding tank. A full-size template is supplied to properly locate fitting holes.

QUALITY

The following features assure the finest performance for years to come:

- Every Hatco FR is equipped with an ECO (Energy Cut-Off) wired into the electrical circuit. This built-in protection "breaks" the power to the elements if the temperature of the water goes above the normal thermostat setting.
- FR models feature a stainless steel tank with a five-year limited warranty.
- An optional low-water cut-off is available to prevent element burn-out due to a low water condition.
- The Hatco FR has separate sump and heating compartment drains for cleaning and sanitizing.



FR-9
(Patented)

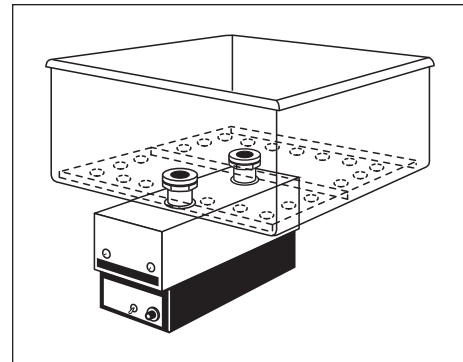

FR Series
Installation
with Vessel
and Baffle
(Supplied by
others)

WATER QUALITY REQUIREMENTS

Incoming water in excess of 3.0 grains of hardness per gallon (GPG) (.75 grains of hardness per liter) must be treated and softened before being supplied to water heater(s). Water containing over 3.0 GPG (.75 GPL) will decrease the efficiency and reduce the operating life of the unit.

Note: Product failure caused by liming or sediment buildup is not covered under warranty.

FOOD RETHERMALIZING REQUIREMENTS

NSF Standard 4 has added performance requirements for food rethermalizing. The requirements mirror the requirements for food rethermalizing in the FDA Food Code. The basic requirement is that food reaches a temperature of 165°F (74°C) in a time period of two hours or less.

Appliances that are manufactured for the purpose of rethermalizing food will need to meet these performance requirements in order to be listed to NSF Standard 4.

Hatco sells a heating unit specifically made to be used for food rethermalizing, however, the heating unit is designed to be incorporated into a hot water bath rethermalizer. Hatco does not supply the vessel that contains the water, nor the system which determines how food is placed and held in the vessel. The Hatco FR unit simply attaches to the bottom of the vessel and supplies hot water to the vessel.

Hatco does supply sizing recommendations to enable the appliance manufacturer to correctly size the FR unit to the vessel. However, there are variables in the way that the vessel is manufactured that affect its ability to pass the NSF performance requirements. The Hatco FR unit is listed with NSF for construction only. Due to the fact that the FR is only a portion of a larger system, it is impossible to do performance testing until the FR unit is incorporated onto the water vessel.

The result is that it is the responsibility of the vessel manufacturer to have the entire rethermalizing appliance tested and listed in accordance with NSF Standard 4. Simply hanging an NSF listed FR unit on the appliance does not transfer NSF listing to the entire appliance.



HATCO CORPORATION P.O. Box 340500 Milwaukee, WI 53234-0500 U.S.A.
(800) 558-0607 • (414) 671-6350 • Fax (800) 543-7521 • Int'l. Fax (414) 671-3976
www.hatcocorp.com • E-mail: equipsales@hatcocorp.com

Form No. FR Spec Sheet

Printed in U.S.A.
August 2009

A City Discount



FR FOOD RETHERMALIZERS / BAIN-MARIE HEATERS

Models FR-3, FR-4, FR-6, FR-9, FR-3B, FR-4B, FR-6B, FR-9B

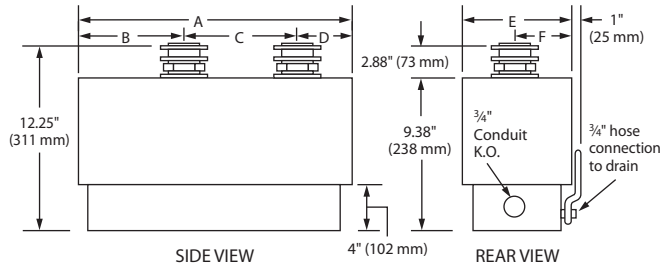

DIMENSIONS

Single or 3-Phase: 6.75"W x 16.88"D x 12.25"H (171 x 429 x 311 mm).
Balanced 3-Phase: 8"W x 17.13"D x 12.25"H (203 x 435 x 311 mm).
FR-9 480V model: 8"W x 17.13"D x 12.63"H (203 x 435 x 321 mm).

Model	A	B	C	D	E	F
1- or 3-phase	16.88"	5.5"	8.5"	2.88"	6.75"	3.38"
	429 mm	140 mm	216 mm	73 mm	171 mm	86 mm
Bal. 3-phase	17.13"	4.63"	8.5"	4"	8"	4"
	435 mm	117 mm	216 mm	102 mm	203 mm	102 mm

VOLTAGE

208 or 240 volts, 50/60 Hz, standard. 480 volts and export voltages available.

PLUG CONFIGURATIONS (FR-3 and FR-4 only)

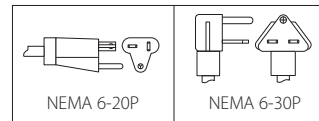

FR-3: 208 or 240 volts uses NEMA 6-20P.

FR-4: 208 volts uses NEMA 6-30P, 240 volts uses NEMA 6-20P, NEMA 6-30P - Canada.

SPECIFICATIONS

Model	kW	Phase	Shipping Weight
FR-3	3.0	1	24 lbs. (11 kg)
FR-4	4.5	1	24 lbs. (11 kg)
FR-6	6.0	1 or 3*	27 lbs. (12 kg)
FR-9	9.0	1 or 3*	27 lbs. (12 kg)
FR-3B	3.0	Balanced 3	30 lbs. (14 kg)
FR-4B	4.5	Balanced 3	30 lbs. (14 kg)
FR-6B	6.8	Balanced 3	30 lbs. (14 kg)
FR-9B	9.0	Balanced 3	30 lbs. (14 kg)

* Open delta on 3-phase. Larger circuit required than for balanced 3-phase of equal kW.

SIZING INFORMATION

For a Bain-Marie or steam table: **MINIMUM 750 WATTS PER SQUARE FOOT** (0,8 watts per sq. cm) of vessel top.

For a Food Rethermalizer: **MINIMUM 2000 WATTS PER SQUARE FOOT** (2,2 watts per sq. cm) of vessel top.

Use one FR for a Bain-Marie up to 6' (1829 mm) long. Over 6' (1829 mm), minimum two required.

MUST BE INSTALLED WITH A PERFORATED WATER BAFFLE. This baffle is **not supplied** with heater. The FR should be positioned with no more than 3' (914 mm) on either side when mounted in holding vessel. Consult factory or installation manual for fabricating details.

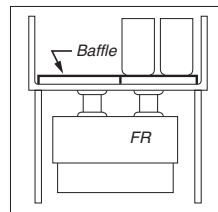

ELECTRICAL RATINGS

208 Volt kW Rating	Phase	Amps	Wire Size AWG	Fuse or Circuit Breaker
3	1	14,5	12	20
4,5	1	22	10	30
6	1	29	8	40
6	3*	25	8	40
6,8	3 (Bal.)	18,8	10	30
9	1	43	4	60
9	3*	37	6	50
9	3 (Bal.)	25	10	40

240 Volt kW Rating	Phase	Amps	Wire Size AWG	Fuse or Circuit Breaker
3	1	12,5	12	20
4,5	1	19	10	30
6	1	25	8	40
6	3*	22	10	30
6,8	3 (Bal.)	14,4	12	20
9	1	38	6	50
9	3*	33	8	40
9	3 (Bal.)	22	10	30

* Open Delta - standard construction (Amperage higher than balanced 3-phase).

OPTIONS (NOT FOR RETROFIT)

- Stainless Steel Body and Base
- Low-Water Cut-Off
- Wiring to CSA Specifications
- 4' (1219 mm) Cord with Plug (NEMA 6-20P) and Receptacle (NEMA 6-20R) (FR-3 only)

- 4' (1219 mm) Cord with Plug (NEMA 6-30P) and Receptacle (NEMA 6-30R) (FR-4 only)
- Security Package

ACCESSORIES

- Flush Hose Kit

PRODUCT SPECS

Food Reconstitutor/Bain-Marie Heater

The electric heater designed to hold foods in the bain-marie or heat and hold frozen foods in a food reconstitutor shall be a Hatco Model ... as manufactured by the Hatco Corporation, Milwaukee, WI 53234 U.S.A.

With 24/7 service (U.S. and Canada only), the Hatco Model FR shall be rated at ... kW, ... volts, ... phase. The heater shall be complete with all internal plumbing and wiring ready for external installation to the bottom of the holding vessel.

The heater tank shall be of stainless steel construction and dual reservoir design; one reservoir to contain a permanently submerged heating

element, the other to trap and collect soil which can be emptied easily by a convenient drain.

The heater shall be equipped with an external thermostat adjustment calibrated from 140°F to 190°F (60° to 88°C) to control the water temperatures and an overtemperature device to protect the unit from overheating. There shall also be an indicator light to signal when water is up to temperature and another to indicate power is on.

The heater shall consist of stainless steel front and silver-gray hammertone body (or stainless steel body and base).

HATCO CORPORATION P.O. Box 340500 Milwaukee, WI 53234-0500 U.S.A. • (800) 558-0607 • (414) 671-6350
Fax (800) 543-7521 • Int'l. Fax (414) 671-3976 • www.hatcocorp.com • E-mail: equipsales@hatcocorp.com