



# Designer Series Electric Hot Plate

Item: \_\_\_\_\_  
 Quantity: \_\_\_\_\_  
 Project: \_\_\_\_\_  
 Approval: \_\_\_\_\_  
 Date: \_\_\_\_\_

Designer Series Electric Hot Plate

Models:

- ED-15H       ED-15HSE       EDU-15HSE



Model ED-15H

### Standard Features:

- Stainless steel front and sides
- 4" (102mm) Sanitary legs
- Easy clean design with recessed protected controls.
- Heat-On indicator lamps
- Two models configurations: ED-15H with two 8" (203mm) coil elements and suffix -15HSE models with two 8" (203mm) sealed solid elements
- "CE" approval only on model EDU-15HSE
- One-Year limited parts & labor warranty (USA & Canada only)

### Optional Features:

- Stainless steel back and bottom

Note : Stands are available see form # CS24/CSD

### Specifications:

Electric designer series hot plates available in two different model configurations. Model ED-15H has two high speed 8 1/2" (216mm) diameter coil elements, with easily removed porcelain enameled bowls and Models with suffix-15HSE have two 9" (229mm) sealed solid elements, with an energy saving feature automatically cycling down when not in use. All models have a six position switch for each element. Designed as stand alone or to be banked with other ED series equipment. 15" (381mm) wide, x 24" (610mm) deep x 11.25" (286mm) high, easy clean design stainless steel front and sides, recessed top and 4" (102mm) stainless steel legs.



Models	Total kW Load				Nominal Amperes Per Line							
					North America				Export			
	North America		Export		Single Phase		Hi Line -3 Phase		Single Phase		Hi Line - 2 or -3 Phase	
208V	240V	220V/380V	240V/415V	208V	240V	208V	240V	220V/380V	240V/415V	220V/380V	240V/415V	
ED-15H	4.2	4.2	4.2	4.2	21	18	18	16	20	18	10	9
ED-15HSE, EDU-15HSE	5.2	5.2	5.2	5.2	25	22	22	19	24	22	12	11

Model	Overall Dimensions			Cu Ft	Shipping Wt. Lb/kg
	Height	Width	Depth		
ED-15H	11-1/4" (286mm)	15" (381mm)	24" (610mm)	5	46/21
ED-15HSE	11-1/4" (286mm)	15" (381mm)	24" (610mm)	5	50/23

Garland products are not approved or authorized for home or residential use, but are intended for commercial applications only. Garland will not provide service, warranty, maintenance or support of any kind other than in commercial applications.

Installation Clearances	
Side	Rear
1.5" (38mm)	1.5" (38mm)

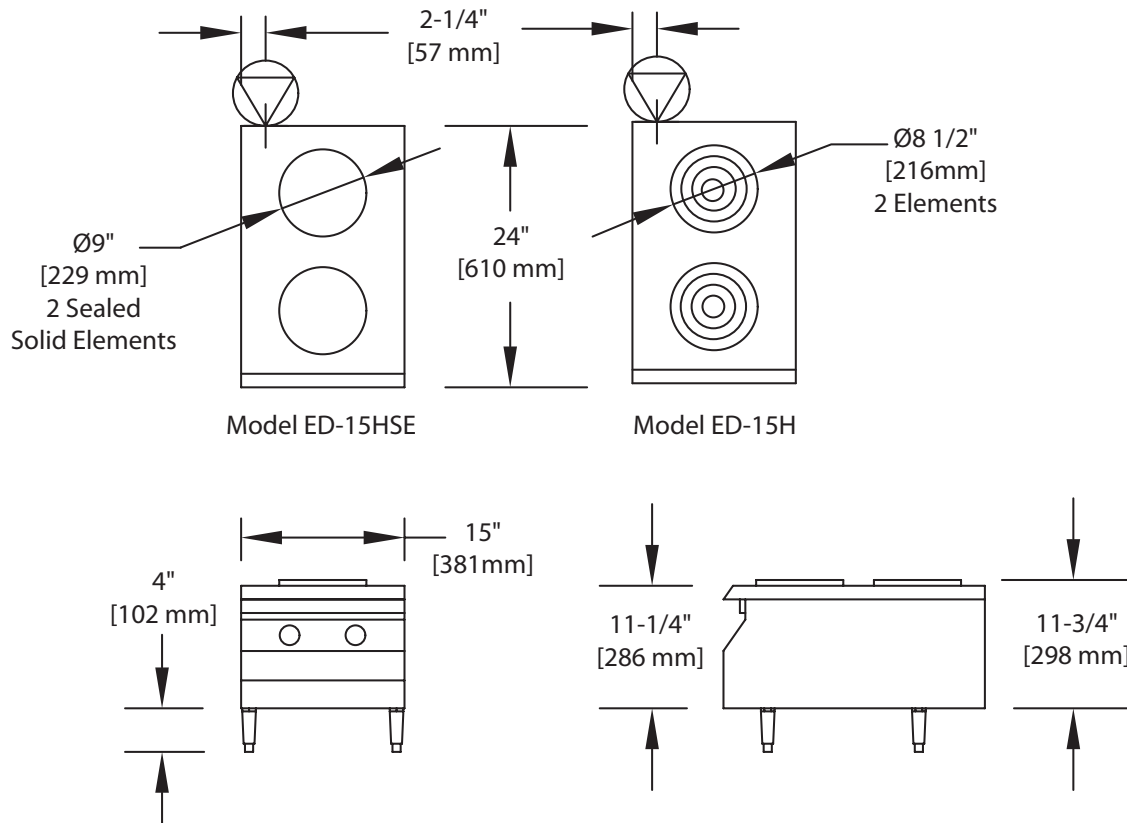

Form# ED-15H, ED-15HSE (09/19/13)