



**TRUE FOOD SERVICE  
EQUIPMENT, INC.**

2001 East Terra Lane • O'Fallon, Missouri 63366  
(636)240-2400 • Fax (636)272-2408 • (800)325-6152 • Intl Fax# (001)636-272-7546  
Parts Dept. (800)424-TRUE • Parts Dept. Fax# (636)272-9471 • www.truefmfg.com

Project Name: \_\_\_\_\_

Location: \_\_\_\_\_

Item #: \_\_\_\_\_ Qty: \_\_\_\_\_

Model #: \_\_\_\_\_

A/A #

S/S #

Model:  
**GDM-23W**

**Glass Door Wine Merchandiser:**  
*Swing Door Refrigerator*



**GDM-23W**

- ▶ The world's #1 manufacturer of glass door merchandisers.
  - ▶ Oversized, factory balanced, refrigeration system holds 33°F to 38°F (.5°C to 3.3°C).
  - ▶ Exterior - non-peel or chip black laminated vinyl; durable and permanent.
  - ▶ Interior - attractive, NSF approved, black aluminum interior sides and top liner with 300 series stainless steel floor. Mirrored back wall.
  - ▶ Self closing door. Positive seal, torsion type closure system. Door lock standard.
  - ▶ "Low-E", double pane thermal insulated glass door assembly with extruded aluminum frame. The latest in energy efficient technology.
  - ▶ Patented integrated door light (IDL) system for brighter, shadow free illumination.
  - ▶ Entire cabinet structure is foamed-in-place using Ecomate. A new, innovative, high density, polyurethane insulation that has zero ozone depletion potential (ODP) and zero global warming potential (GWP).
  - ▶ Four (4) adjustable wine racks and one (1) adjustable, heavy duty, black PVC coated wire shelf.
- Bottom mounted units feature**
- ▶ "No stoop" lower shelf to maximize product visibility.
  - ▶ Storage on top of cabinet.
  - ▶ Easily accessible condenser coil for cleaning.

**ROUGH-IN DATA**

Specifications subject to change without notice.  
Chart dimensions rounded up to the nearest 1/8" (millimeters rounded up to next whole number).

Model	Doors	Shelves		Cabinet Dimensions (inches) (mm)			HP	Voltage	Amps	NEMA Config.	Cord Length (total ft.) (total m)	Crated Weight (lbs.) (kg)
		Wire	Wine	L	D†	H						
GDM-23W	1	1	4	27 686	29 7/8 759	78 5/8 1998	1/3 1/3	115/60/1 230-240/50/1	7.2 3.0	5-15P ▲	9 2.74	305 139

† Depth does not include 1 1/8" (29 mm) for door handle.

▲ Plug type varies by country.

<p>Printed in U.S.A.</p>	<p><b>APPROVALS:</b></p>	<p><b>AVAILABLE AT:</b></p>
--------------------------	--------------------------	-----------------------------

Model:  
**GDM-23W**

## Glass Door Wine Merchandiser: Swing Door Refrigerator



### STANDARD FEATURES

#### DESIGN

- True's commitment to using the highest quality materials and oversized refrigeration systems provides the user with colder product temperatures, and lower utility costs in an attractive merchandiser that brilliantly displays wine and alcohol products.

#### REFRIGERATION SYSTEM

- Factory engineered, self-contained, capillary tube system using environmentally friendly (CFC free) 134A refrigerant.
- Extra large evaporator coil balanced with higher horsepower compressor and large condenser; maintains cabinet temperature of 33°F to 38°F (5°C to 3.3°C).
- Sealed, cast iron, self-lubricating evaporator fan motor(s) and larger fan blades give True merchandisers a more efficient low velocity, high volume airflow design. This unique design ensures faster temperature pull down of warm product, colder holding temperatures and faster recovery in high use situations.
- Bottom mounted condensing unit positioned for easy maintenance. "No stoop" lower shelf maximizes visibility by raising merchandised product to higher level.

#### CABINET CONSTRUCTION

- Exterior - non-peel or chip black laminated vinyl; durable and permanent.
- Interior - attractive, NSF approved, black aluminum sides and top liner with 300 series stainless steel floor. Mirrored interior back.
- Insulation - entire cabinet structure is foamed-in-place using Ecomate. A new, innovative, high density, polyurethane insulation that has zero ozone depletion potential (ODP) and zero global warming potential (GWP).
- Welded, heavy duty steel frame rail, black powder coated for corrosion protection.

- Frame rail fitted with leg levelers.
- Illuminated exterior sign panel. Variety of sign options available.

#### DOOR

- "Low-E", double pane thermal insulated glass door assembly with extruded aluminum frame. The latest in energy efficient technology. Door lock standard.
- Door fitted with 12" (305 mm) long extruded handle.
- Self closing door. Positive seal, torsion type closure system.
- Magnetic door gasket of one piece construction, removable without tools for ease of cleaning.

#### SHELVING

- Four (4) adjustable wine racks 22<sup>9</sup>/<sub>16</sub>"L x 21<sup>1</sup>/<sub>8</sub>"D (574 mm x 537 mm) and one (1) adjustable, heavy duty, black PVC coated wire shelf 22<sup>9</sup>/<sub>16</sub>"L x 23<sup>1</sup>/<sub>4</sub>"D (574 mm x 591 mm). Four (4) chrome plated shelf clips included per rack and shelf.
- Shelf support pilasters made of same material as cabinet interior; shelves are adjustable on 1/2" (13 mm) increments.

#### LIGHTING

- Low UV emitting fluorescent interior lighting. Door utilizes full-length, patented, integrated door light (IDL) system. Safety shielded.
- Cabinet lighting utilizes electronic ballast and T-8 bulbs for brighter illumination, longer bulb life and increased energy efficiency.

#### MODEL FEATURES

- Evaporator is epoxy coated to eliminate the potential of corrosion.
- See our website [www.truemfg.com](http://www.truemfg.com) for latest color and sign offerings.
- Convenient clean-out drain built in cabinet floor.

#### ELECTRICAL

- Unit completely pre-wired at factory and ready for final connection to a 115/60/1 phase, 15 amp dedicated outlet. Cord and plug set included.



115/60/1  
NEMA-5-15R

#### OPTIONAL FEATURES/ACCESSORIES

Upcharge and lead times may apply.

- 230 - 240V / 50 Hz.
- White exterior.
- Rosewood exterior.
- 6" (153 mm) standard legs.
- 6" (153 mm) seismic/flanged legs.
- 2<sup>1</sup>/<sub>2</sub>" (64 mm) diameter castors.
- Red wine thermostat.
- White wine thermostat.
- Chocolate thermostat.
- Sliding wine racks.
- Additional black wine racks.
- Additional black wire shelves.
- White wire shelves.
- TrueTracIII gravity feed organizers.
- TrueTrac4 gravity feed organizers.
- 1<sup>1</sup>/<sub>4</sub>" (32 mm) pricing strips.
- Remote cabinets (condensing unit supplied by others; system comes standard with 404A expansion valve and requires R404A refrigerant). Consult factory technical service department for BTU information. All remote units must be hard wired during installation.

### PLAN VIEW

CUBIC FEET 23  
\*Based on ANSI/AHAM HRF-1-2004

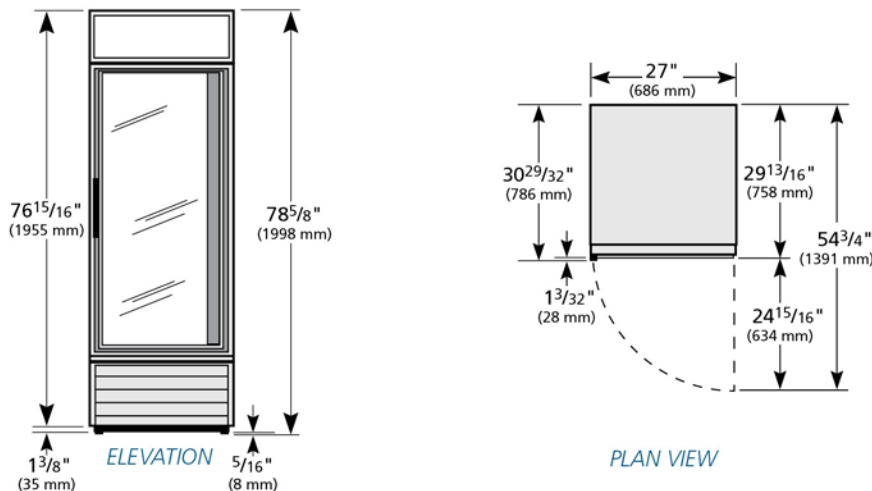

#### WARRANTY

One year warranty on all parts and labor and an additional 4 year warranty on compressor. (U.S.A. only)

METRIC DIMENSIONS ROUNDED UP TO THE NEAREST WHOLE MILLIMETER

SPECIFICATIONS SUBJECT TO CHANGE WITHOUT NOTICE



Model	Elevation	Right	Plan	3D	Back
GDM-23W	TFAZ03E	TFAY03S	TFAZ03P	TFAZ033	

### TRUE FOOD SERVICE EQUIPMENT

2001 East Terra Lane • O'Fallon, Missouri 63366 • (636)240-2400 • Fax (636)272-2408 • (800)325-6152 • Intl. Fax# (001)636-272-7546 • [www.truemfg.com](http://www.truemfg.com)

A City Discount