



**TRUE FOOD SERVICE  
EQUIPMENT, INC.**

St. Charles Industrial Center • P.O. Box 970 • O'Fallon, Missouri 63366  
(636)240-2400 • FAX (636)272-2408 • (800)325-6152 • www.truemfg.com  
Parts Dept. (800)424-TRUE • Parts Dept. FAX# (636)272-9471

Project Name: \_\_\_\_\_

Location: \_\_\_\_\_

Item #: \_\_\_\_\_ Qty: \_\_\_\_\_

Model #: \_\_\_\_\_

A/A #

SIS #

Model:  
**GDM-35F**

**Glass Door Merchandiser:**  
Freezer



**GDM-35F**

- ▶ The world's #1 manufacturer of glass door merchandisers.
  - ▶ Designed using the highest quality materials and components to provide the user with an attractive, point of purchase merchandiser that brilliantly displays frozen food and ice cream, resulting in high impulse sales.
  - ▶ Oversized, factory balanced, refrigeration system holds -10°F (-23.33°C).
  - ▶ Exterior - non-peel or chip white laminated vinyl; durable and permanent.
  - ▶ Interior - attractive, NSF approved, white aluminum interior liner with 300 series stainless steel floor.
  - ▶ Self closing doors. Positive seal, torsion type closure system.
  - ▶ "Low-E", double pane thermal glass door assembly with extruded aluminum frames. The latest in energy efficient technology.
  - ▶ Patented integrated door light (IDL) system for brighter, shadow free illumination.
  - ▶ Entire cabinet structure and solid doors are foamed-in-place using high density, CFC free, polyurethane insulation.
- Bottom mounted units feature**
- ▶ "No stoop" lower shelf to maximize product visibility
  - ▶ Storage on top of cabinet.
  - ▶ Easily accessible condenser coil for cleaning.

**ROUGH-IN DATA**

Specifications subject to change without notice.  
Chart dimensions rounded up to the nearest 1/8" (millimeters rounded up to next whole number).

Model	Glass Front Doors	Capacity (Cu. Ft.) (liters)	# of Shelves	Cabinet Dimensions (inches) (mm)			HP	Voltage	Amps	NEMA Config.	Cord Length (total ft.) (total m)	Crated Weight (lbs.) (kg)
				L	D†	H						
GDM-35F	2	35 992	8	39 1/2	29 7/8	78 5/8	1	115/208-230/60/1 230-240/50/1	9.5	14-20P	9	540
				1004	759	1998						

† Depth does not include 1 1/8" (29 mm) for door handles  
Requires 115/208-230/60 Hz, single phase, 3 pole, 4 wire circuit.

▲ Plug type varies by country.

3/04 Printed in U.S.A.

**APPROVALS:**

Model:  
**GDM-35F**

**Glass Door Merchandiser:**  
Freezer



## STANDARD FEATURES

### DESIGN

- True's commitment to using the highest quality materials and oversized refrigeration systems provides the user with colder product temperatures, and lower utility costs in an attractive merchandiser that brilliantly displays frozen food and ice cream.

### REFRIGERATION SYSTEM

- Factory engineered self-contained, capillary tube system using environmentally friendly (CFC free) R404A refrigerant.
- Extra large evaporator coil balanced with higher horsepower compressor and large condenser; maintains -10°F (-23.33°C).
- Sealed, cast iron, self-lubricating evaporator fan motors and larger fan blades give True merchandisers a superior low velocity, high volume airflow design. This unique design insures colder standard temperatures and faster recovery in high use situations.
- Bottom mounted condensing unit positioned for easy maintenance. "No stoop" lower shelf maximizes visibility by raising merchandised product to higher level.
- Defrost system time-initiated, temperature-terminated. Saves energy consumption and provides shortest possible defrost cycle.

### CABINET CONSTRUCTION

- Exterior - non-peel or chip white laminated vinyl; durable and permanent.
- Interior - attractive, NSF approved, white aluminum liner with 300 series stainless steel floor.
- Insulation - entire cabinet structure is foamed-in-place using high density, CFC free,

polyurethane insulation.

- Cabinet mounted on a welded, heavy duty galvanized frame rail. Rail dipped in rust inhibiting enamel paint for corrosion protection. Rail fitted with leg levelers.
- Illuminated exterior sign panel. Variety of sign options available.

### DOORS

- "Low-E", double pane thermal glass door assembly with extruded aluminum frames. The latest in energy efficient technology.
- Self closing doors. Positive seal, torsion type closure system.
- Doors fitted with 15" (381 mm) extruded aluminum handles.
- Magnetic door gaskets of one piece construction, removable without tools for ease of cleaning.

### SHELVING

- Eight (8) adjustable, heavy duty PVC coated wire shelves 17 1/2" L x 20 3/4" D (445 mm x 528 mm). Four (4) chrome plated shelf clips included for each shelf.
- Shelf support pilasters made of same material as cabinet interior; shelves are adjustable on 1/2" (13 mm) increments.

### LIGHTING

- Safety shielded fluorescent interior lighting. Doors utilize full-length, patented, integrated door light (IDL) system.
- Cabinet lighting utilizes electronic ballast and T-8 bulbs for brighter illumination, longer bulb life and increased energy efficiency.

### MODEL FEATURES

- Evaporator is epoxy coated to eliminate the potential of corrosion.

- See our website [www.truemfg.com](http://www.truemfg.com) for latest color and sign offerings.
- Backguard and floor rack insures optimum airflow.

### ELECTRICAL

- Unit completely pre-wired at factory and ready for final connection to a 115/208-230/60Hz single phase - 20 amp dedicated outlet. Cord and plug set included.



115/208-230/1  
NEMA-14-20R

### OPTIONAL FEATURES / ACCESSORIES

- 230 - 240V / 50 Hz
- Black, walnut, rosewood and stainless exterior.
- Black aluminum and stainless interior.
- Castors.
- Padlocks.
- Remote cabinets (condensing unit supplied by others), consult factory technical service department for BTU information.

## PLAN VIEW

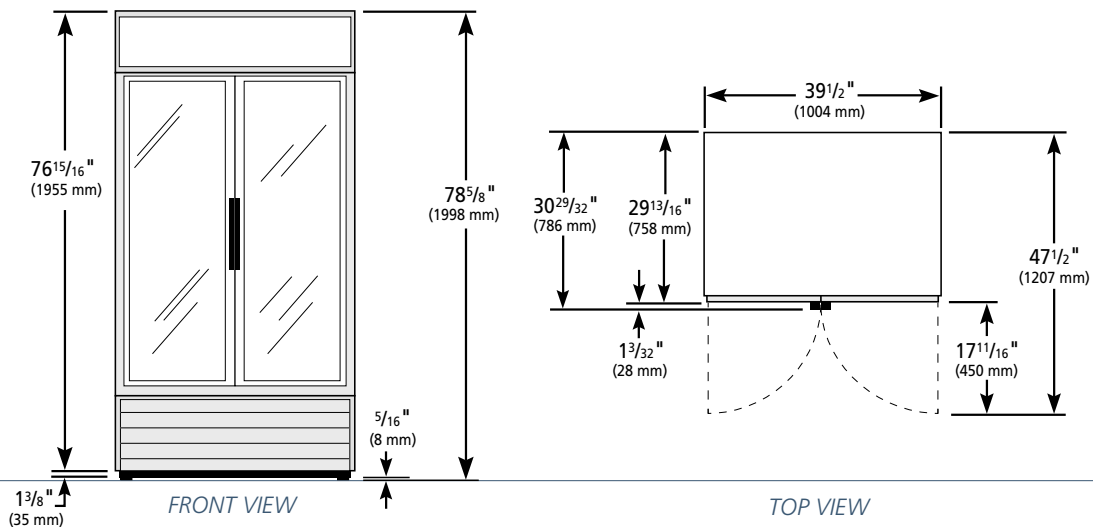

### WARRANTY

One year warranty on all parts & labor and an additional 4 year warranty on compressor. (U.S.A. only)

METRIC DIMENSIONS ROUNDED UP TO THE NEAREST WHOLE MILLIMETER  
SPECIFICATIONS SUBJECT TO CHANGE WITHOUT NOTICE



Model	Front	Side	Plan	3D
GDM-35F	TFAY17E	TFAY17S	TFAY17P	TFAY173

## TRUE FOOD SERVICE EQUIPMENT