

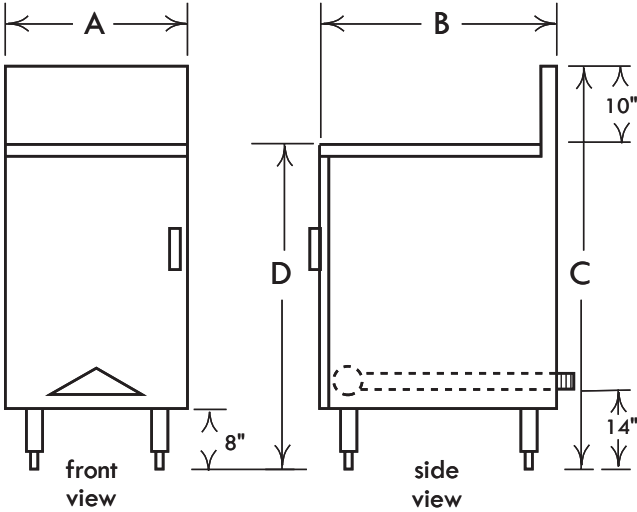

JOB _____ ITEM # _____
TWIN TANK FRYER
 GF120T



GF120T



Standard Features, Benefits & Options

CONSTRUCTION: Space saving 15.5" wide frame and 2 separate fry vats to segregate flavor clashing foods and taste transfer. Easy cleaning, stainless steel tank, flue, sides & door. Integrated inner door liner for door stability. Adjustable 6" stainless steel legs for easy leveling. Requires a 6" (152mm) clearance on the sides and rear to combustible surfaces.

CONTROLS: 2 each Invensys Thermostats - 200°F to 400°F, 100% safety shutoff with built in pressure regulators, high limit controls for back-up safety and automatic standing pilot and brass burner valves. Optimal pressures are 4" (102mm) WC for natural gas and 10" (279mm) WC for propane. 2 gas manifold connections each 1/2" NPT. All controls are tested and confirmed in good working order. Calibration and adjustments are the responsibility of the installer.

TANK: 2 separated fry vats. 16 guage stainless steel tube type tank for maximum surface heat transfer. Bead blasted to remove weld marks and burrs for easier cleaning. Built in flue deflector. Deep cold zone allows food particles to sink below tubes, extending the life and quality of fryer shortening. 2 each, 1 1/4" ball valves for rapid draining.

BASKETS: Two heavy duty, nickel plated wire baskets with coated handles. The basket hanger suspends loaded baskets out of frying vat and is removeable for easy back splash cleaning.

ACCESSORIES: Casters, stainless steel tank covers, joiner strips, flame shields, gas hoses and cleaning supplies.

SPECIFICATIONS		
Model - GF120T		
Width "A"	in.	15.5
	cm.	39.4
Depth "B"	in.	30.25
	cm.	76.8
Height "C"	in.	47.13
	cm.	119.7
Working Height "D"	in.	36.25
	cm.	92.1
Ship Weight	lbs.	170
	kgs.	77
Burner Quantity	4	
Total BTU	120,000	
Fryer Tank Fill Chart Guide		
Total Gallons	6	
Liters	24	
Pounds	50	
Kilograms	23	

Rev 10/5/2018

NOTICE: In an ongoing effort of product development & improvement, Comstock-Castle reserves the right to change specifications and product design without notice. Such modifications do not entitle the buyer to corresponding changes or replacements for previously purchased equipment.



Comstock-Castle Stove Co. • 119 W. Washington St. • Quincy, IL. 62301
Tel.: 217-223-5070 • Fax: 217-223-0007 • www.castlestove.com

