



# Champion Gas Hot Plate Standard Series

Models:  GHPW-2H  GHPW-3H

PRODUCT:

QUANTITY:

ITEM #:

## Designed Smart

### Increased Performance in Cooking

- Champion high output gas burners generate more than 36% more BTU's than competitive hot plates (30,000 BTU's per burner).
- Reduces amount of labor time to boil water by 50%.
- Fast start-up to prime cooking temperatures.
- Openings in the front allow the pilot light to be easily lit and adjusted without removing the front panel.

### Safety Features

- New bull-nose front extension protects employees from burns.

### Saves Time and Clean-Up Labor Cost

- Maintenance is easier with bottom-mounted grease collection pan and removable top grates.
- Field convertible and adjustable gas regulator.

## Built Solid

### Built to Last!

- Thick, stainless steel construction on front panel and top skirt protects against kitchen "wear and tear" and rust.
- Thick cast iron grates stand up to years of high output use.
- Welded construction--.

### Reliability backed by APW Wyott's Warranty

- APW Wyott cooking equipment is backed by a 3-year limited warranty, and a 1-year on-site labor warranty.
- Certified by the following agencies:



\*Warranty does not include cooking grates or fireboxes



Models GHPW-2H and 3H Shown with optional wok rings

## APW Wyott Design Features

- Heavy-duty stainless steel and aluminized steel construction
- 30,000 BTU/hr per cast iron burner
- Smooth action, infinitely adjustable gas valves turn 180 degrees, giving the operator ultimate control.
- Field convertible and adjustable gas regulator
- Removable cast-iron grate
- Stainless steel collection pans
- Adjustable viewable pilot
- 4" (10 cm) adjustable legs
- Front or top-servicing
- High altitude versions available (contact factory)

## Options & Accessories

- WOK Ring Accessory - Part # 21815507

See reverse side for product specifications.



APW Wyott Foodservice Equipment Company · 729 Third Ave., Dallas, TX 75226  
(800) 527-2100 · (214) 421-7366 · Fax (214) 565-0976 · www.apwwyott.com · info@apwwyott.com

Rev. 12/13/2006

PRODUCT:

QUANTITY:

ITEM #:

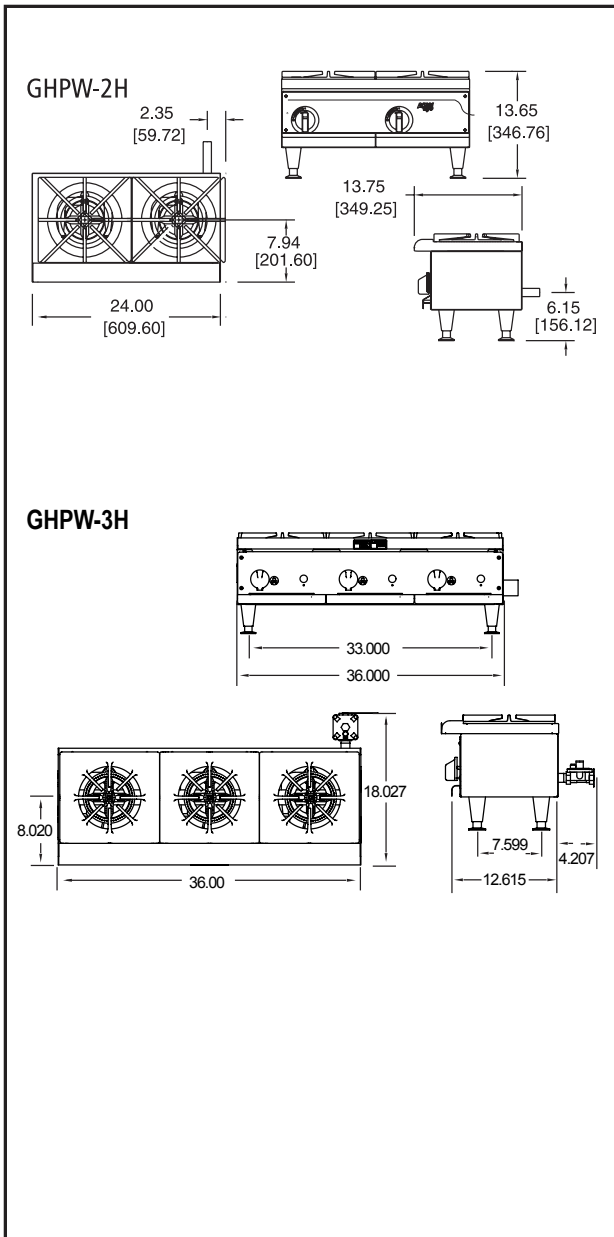

## PRODUCT SPECIFICATIONS

### Construction:

Stainless steel top skirt, crumb tray and front panel. Aluminized steel sides and back panel. Welded construction. Field convertible gas regulator. 4" adjustable legs.

### Gas Specifications:

GHPW-2H: 60,000 BTU/hr. input  
2 manual infinitely adjustable controls  
(Propane is 60,000 BTU/hr.)

GHPW-3H: 90,000 BTU/hr. input  
3 manual infinitely adjustable controls  
(Propane is 90,000 BTU/hr.)

### Overall Dimensions:

GHPW-2H: 13 1/2" H x 24" W x 13 3/4" D  
(34.3 cm x 61 cm x 30.5 cm)

GHPW-3H: 13 2/3" H x 36" W x 13 3/4" D  
(34.7 cm x 91 cm x 30.5 cm)

Note: Regulator and pipe add 1 1/4" to the rear of the unit.

### Shipping:

GHPW-2H: 64 lbs. (29 kg)

GHPW-3H: 104 lbs. (47.2 kg)

Freight Class: 85  
FOB: Cheyenne, WY

\*APW Wyott reserves the right to modify specifications or discontinue models without incurring obligation.