

Project Name: _____ AIA#: _____

Model #: _____ Location: _____

SIS#: _____ Item #: _____ Quantity: _____



Price Computing Scales

Model GS30 ▪ GS30T (with display tower)



**LEGAL
FOR
TRADE**

GS30T



GS30

Shown with optional plastic scoop.



Standard Features

- Legal for trade
- Built-in rechargeable battery or AC powered
- Easy to read dual LCD display, with .63" numerals, showing:
 - Weight
 - Unit price
 - Total price
- Automatic entry tare
- Adds multiple transactions
- Auto zero tracking on power up
- Automatic shut off if not used
- Weight capacity — .01 to 30 lbs.
- Easy to clean removable, 11.75" x 8.75" recessed stainless steel platter

Warranty

- *One-year parts and labor*



Dual easy-to-view LCD display, accurate and versatile, choose model with or without display tower.

Optional Item

- Plastic scoop

To select options, see complete list on back

Approved by: _____ Date: _____

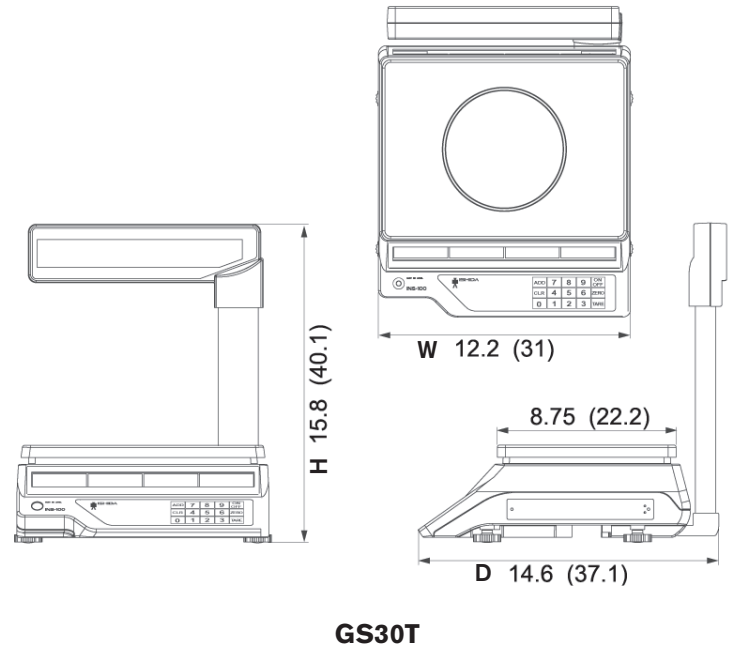
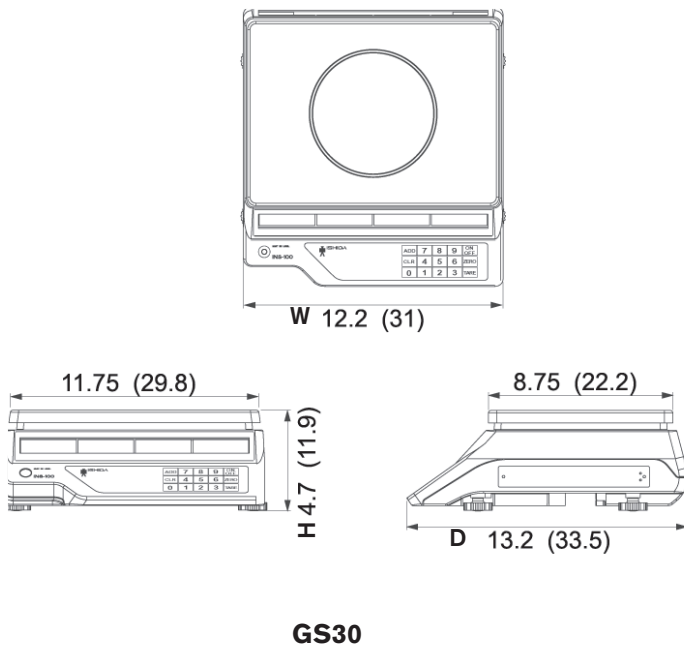

Power Requirements: 115-60-1, 0.1 AMPS

Cord and Plug: Attached 6 ft. flexible 3 wire cord and plug, fits grounded receptacle, NEMA 5-15P (⚡)

DIMENSIONS | SHIPPING INFORMATION

Reinforced carton for shipping. The weight and dimensions of this reinforced carton are included below and may vary from shipment to shipment.

	Base Foot Print	Overall Dimensions	Net Wt	Shipping Dimensions	Ship Wt
GS30	12.2" w x 13.2" d (31 cm x 33.5 cm)	12.2" w x 13.2" d x 4.7" h (31 cm x 33.5 cm x 11.9 cm)	10.5 lbs (4.8 kg)	19" w x 17" d x 9" h (48 cm x 43 cm x 23 cm)	13.5 lbs (11.4 kg)
GS30T	12.2" w x 14.6" d (31 cm x 37 cm)	12.2" w x 14.6" d x 15.8" h (31 cm x 37 cm x 40 cm)	12 lbs (5.4 kg)	20" w x 21.3" d x 10" h (51 cm x 43 cm x 25.4 cm)	15.5 lbs (7 kg)

Scale is legal for trade with dual LCD display of weight, unit and total price (model also available with tower display). Unit has automatic entry tare, zero tracking on power up and auto shut off. Scale adds multiple transactions, weight capacity is .01 - 30 lbs. Includes stainless steel removable platter. Unit is UL and NTEP listed. One year parts and labor warranty.

OPTIONAL ITEM: **SCOOP** Plastic scoop, 10" dia. x 2.5" deep