

GLASS WASHING

ROTARY STYLE GLASS WASHER

MODEL: _____ PROJECT: _____ ITEM #: _____ QTY: _____

PRODUCT IMAGE



GWR-24 SHOWN

AVAILABLE ONLY IN 25" SIZE

OPTIONAL ACCESSORIES

- **28-111S** 3 1/2" x 3 1/2" Plate Caster with 5" Locking Wheel

STANDARD FEATURES

- Low Temperature
- Stainless Steel construction
- **Free 1 Year Warranty** if Glass Washing Dump Sink is purchased and placed next to Glasswasher in Bar Line-Up -5°F to 10°F temperature range
- 26" Front to Back depth, 39" Height
- 12" glass clearance accepts taller stemware
- Internal upper drain screen for improved filtration and ease of cleaning
- Self flushing wash chamber reduces maintenance
- Reduced water usage
- 208-230 V connection
- Three-pump injection system for precise chemical dispensing
- Upper and lower wash and rinse arms produce sparkling clean glasses every time
- Double walled construction for quieter operation
- Cool final rinse water provides a cool glass ready for immediate use
- Cabinet below holds the 3 chemicals required each in 1 gallon containers
- Polypropylene conveyor virtually eliminates chipping of fine stemware



CERTIFICATIONS:

APPROVED BY:

Due to our commitment to continued product improvement, specifications are subject to change without notice.

GLASS WASHING

ROTARY STYLE GLASS WASHER

MODEL: _____ PROJECT: _____ ITEM #: _____ QTY: _____

25" ROTARY STYLE GLASS WASHER

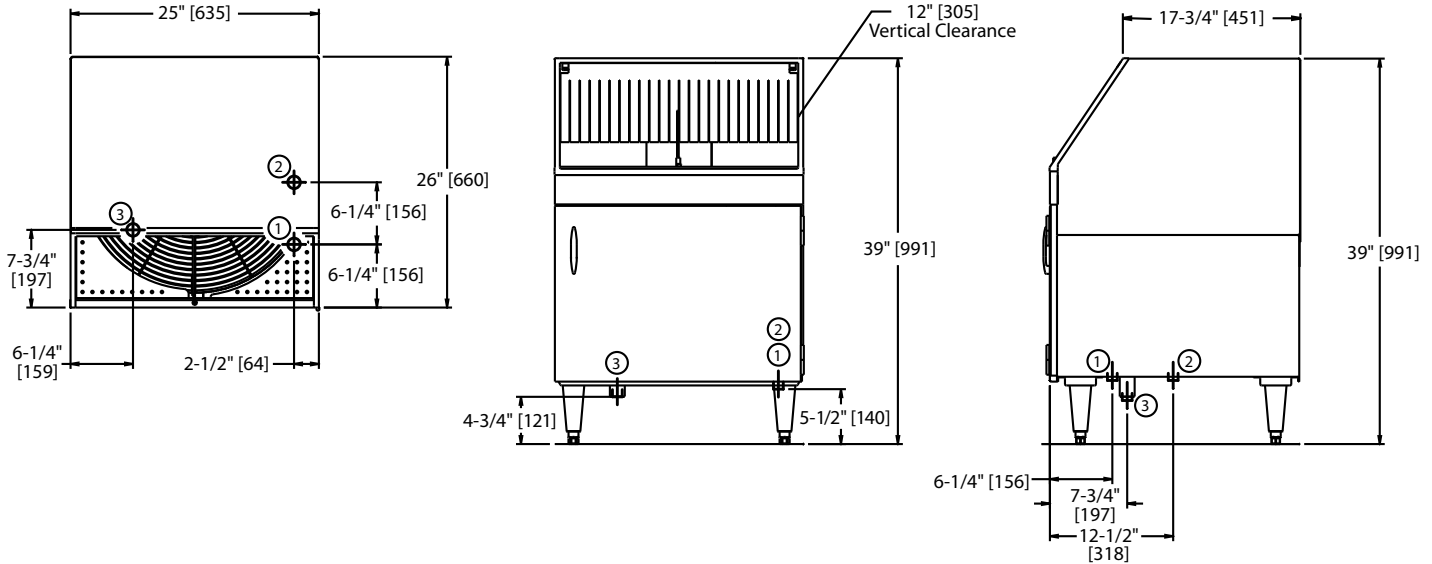

PLAN VIEW

FRONT VIEW

SIDE VIEW

SPECIFICATIONS

CAPACITY / HR.	
2 1/2" glasses	1200
WATER CONSUMPTION	
Cold water (approx.)	2.5 gpm
Hot water (initial fill)	3 gpm
Max use (approx.)	10 gph
TEMPERATURES °F/C	
Inlet water (hot)	140-160
Inlet water (cold)	75
HEATING	
Tank heat, electric (kW)	3
CONVEYOR MOVEMENT	
Clockwise	

NOTE: Unit is supplied with 6 ft. [1829] plug-in cord. (NEMA 6-15P)

WARNING: Plumbing and electrical connections should be made by qualified personnel who will observe all applicable plumbing, sanitary and safety codes.

UTILITIES

ELECTRICAL	
208-230/60/1, 15 amp	
Ⓐ HOT WATER CONNECTION	1/2" IPS. Flow pressure 25-95 psi.
Ⓑ COLD WATER CONNECTION	1/2" IPS. Flow pressure 25-95 psi.
Ⓒ DRAIN CONNECTION	1 1/2" tailpiece Connect to drain size according to local plumbing code

UNIT DIMENSIONS

	UNCRATED	CRATED
HEIGHT	39"	46 1/2"
WIDTH	25"	27"
DEPTH	27"	27 1/2"
SHIP WT. (lbs.)	156	176



CERTIFICATIONS:

APPROVED BY:

Due to our commitment to continued product improvement, specifications are subject to change without notice.