



DS24  
with stainless steel door and top



**Intertek**

4004503

Conforms to NSF/ANSI STD 2

Project: _____	AIA# _____
Item #: _____ Qty: _____	SIS# _____
Model #: _____	

## Dry Storage Cabinets

<b>DS</b>	DS24, DS40, DS48, DS60, DS72, DS80, DS96
-----------	--

### Configurable Options

**Door Style & Finish:**

- Black vinyl-clad
- Stainless steel
- Jeweled stainless
- Laminated
- Unlaminated

**Top Style:**

- No finished top
- Stainless top

**Left and Right Side Finish:**

- Black vinyl-clad
- Stainless steel

**Door Hinge Location** (*specify for each door*):

- Left or Right

**Door Handle:**

- Signature
- Pull-tab
- Tube

### Standard Features

- Locking door(s)
- Eco-friendly, foamed-in-place insulated sides and door (excluding DS24 sides)
- Stainless steel sub top (excluding DS24, which has an open top)
- Black vinyl-clad steel exterior front and sides
- Two adjustable, coated-wire shelves per door section (DS24 excluded)
- DS24 includes 16 gauge galvanized shelves

To view underbar installation instructions, please visit: [https://www.glastender.com/PDF/F-750-165\\_Underbar\\_Installation\\_Instructions.pdf](https://www.glastender.com/PDF/F-750-165_Underbar_Installation_Instructions.pdf)

To view cleaning and care instructions, please visit: [https://www.glastender.com/PDF/F-423-011\\_ss\\_clean\\_care.pdf](https://www.glastender.com/PDF/F-423-011_ss_clean_care.pdf)

<b>Glastender, Inc.</b> • 5400 N Michigan Rd • Saginaw, MI • 48604-9780 989.752.4275 • 800.748.0423 • Fax 989.752.4444 <a href="http://www.glastender.com">www.glastender.com</a>	Approval/Notes:
Specifications subject to change without notice. For current specifications please visit our website.	

# Dry Storage Cabinet

## Specifications

		DS24	DS40	DS48	DS60	DS72	DS80	DS96
Dimensions	Length	24"	40"	48"	60"	72"	80"	96"
	Number of Sections	1	2	2	3	3	4	4
	Door Opening	21"	16"	20"	16"	20"	16"	20"
Weight Bearing Capacity		Countertops and other accessories should not exceed 500 pounds per door						

### Materials

- Stainless steel parts include: exterior sub-top (DS24 excluded), interior, front of cabinet, hinges, hinge and lock brackets, and optional legs
- Black vinyl-clad steel parts include: standard sides, doors and compressor cover
- Galvanized steel parts: interior
- Zinc plated CR steel parts include: leg sockets

# Dry Storage Cabinets

## Drawings

### PLAN VIEW

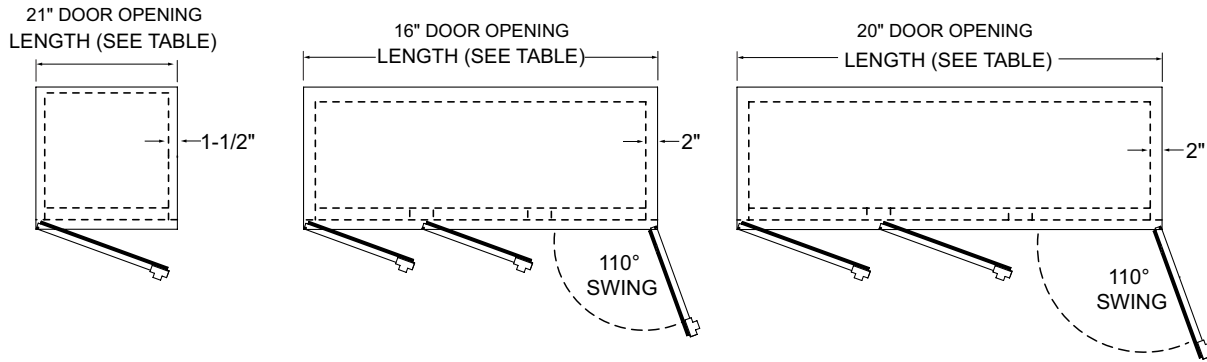

### FRONT VIEW

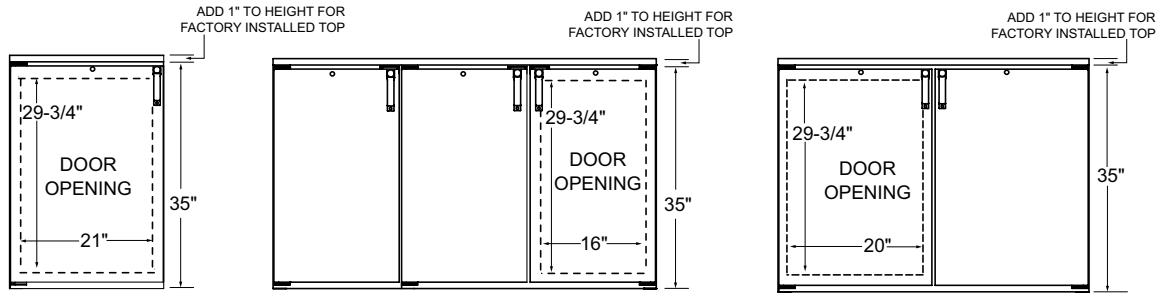

### SIDE VIEWS

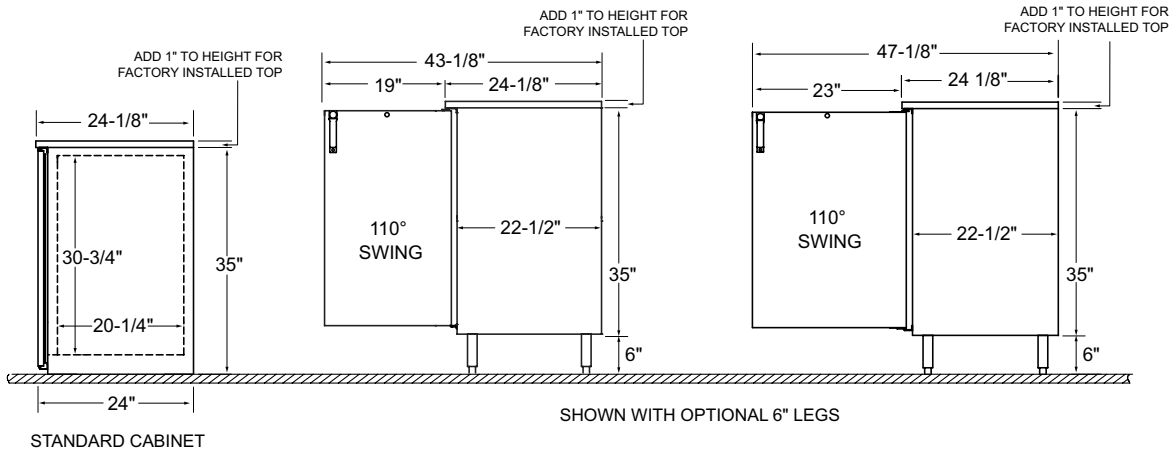

OPTIONAL LEGS AND CASTERS



6" LEG

4-1/8" CASTER

2-7/8" CASTER



5400 N Michigan Rd • Saginaw, MI • 48604-9780  
 989.752.4275 • 800.748.0423 • Fax 989.752.4444  
 www.glastender.com

Printed in USA