



MF36-B2



Project: _____	AIA# _____
Item #: _____ Qty: _____	SIS# _____
Model #: _____	

Mug Frosters

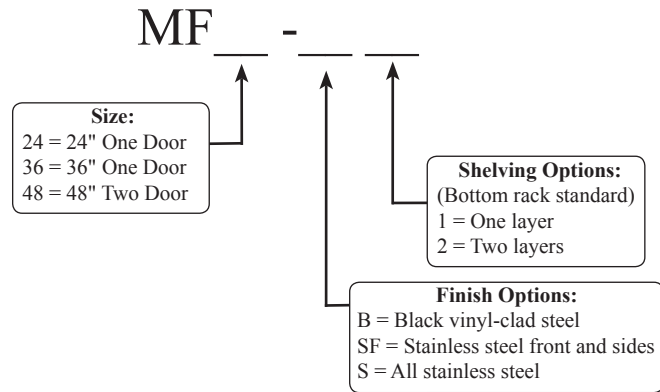

Standard Features

- Self-contained refrigeration
- All 300 series stainless steel interior construction with radius corners for easy cleaning
- Perfect exterior dimensions: 24" front to back and 24", 36", or 48" left to right
- CFC free foamed-in-place insulation
- Two Defrost Cycles: *automatic* - occurs every six hours without affecting normal operation, *manual* - user selected for complete six-hour defrost with automatic restart
- 3-3/4" casters or 6" legs are available
- Three exterior options: black vinyl-clad steel, stainless steel front & sides, or all stainless steel
- Three shelving options: standard (bottom), one additional layer, or two additional layers
- Six-foot grounded cord & plug included (exits left rear)
- Automatic condensate evaporator - no drain connection required
- One-piece integral top and mullion design

Specifications

- Electrical**
- 115V, 1 phase, 60 Hz, 8.2 full load amps
 - Dedicated 15 amp circuit is recommended
 - Includes a 6-foot grounded cord and plug which exits the left rear of the refrigeration compartment
- Refrigeration**
- 1/3 HP, 404A refrigerant
 - Operating range: -15°F to 0°F
 - Fin & tube evaporator with forced air circulation
- Plumbing**
- Interior floor drain and condensate drain to automatic evaporator. No drain connection required
- Capacity**
- 24" Model: 105 10-oz mug total capacity; 41 bottom shelf, 41 middle shelf, 23 top shelf
 - 36" Model: 175 10-oz mug total capacity; 64 bottom shelf, 64 middle shelf, 47 top shelf
 - 48" Model: 252 10-oz mug total capacity; 90 bottom shelf, 90 middle shelf, 72 top shelf

- Legs**
- 1-5/8" diameter
 - Stainless steel bullet feet
- Materials**
- 20 gauge 300 series stainless steel parts include: top, door, interior floor, back*, front*, and sides* (*if all stainless finish is specified)
 - 20 gauge black vinyl-clad steel parts include: sides, front, and back (if black vinyl-clad steel exterior is specified)
 - 22 gauge 300 series stainless steel parts include: interior walls
 - 16 gauge stainless steel parts include: legs* (* if specified)
 - 16 gauge galvanized steel parts include: base

Glastender, Inc. • 5400 N Michigan Rd • Saginaw, MI • 48604-9780 989.752.4275 • 800.748.0423 • Fax 989.752.4444 www.glastender.com	Approval/Notes:
Specifications subject to change without notice. For current specifications please visit our website.	

Mug Frosters

Dimensional Information

Model	A	B	No. of Doors
MF24	24"	20"	1
MF36	36"	32"	1
MF48	48"	44"	2

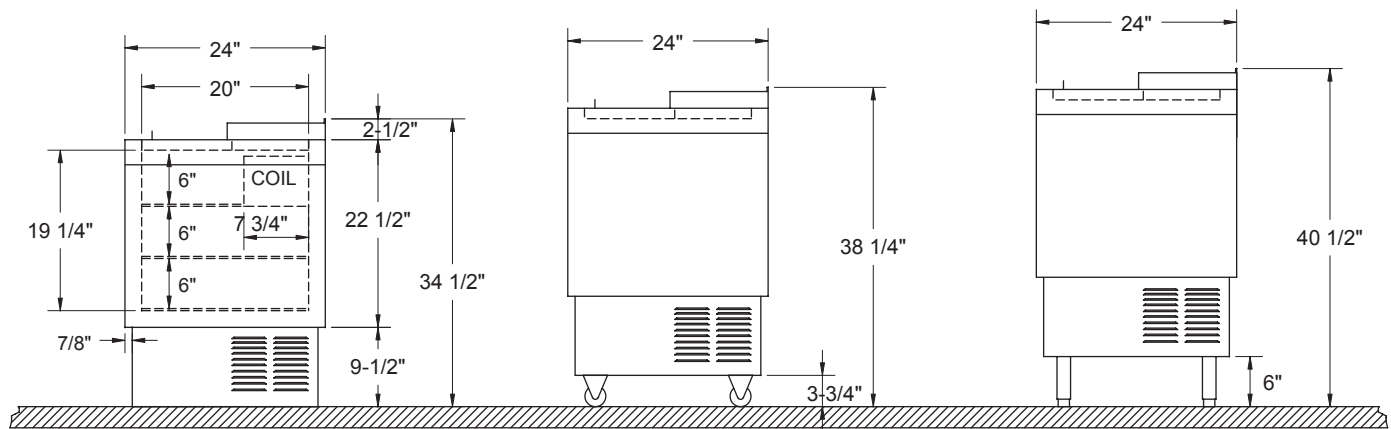
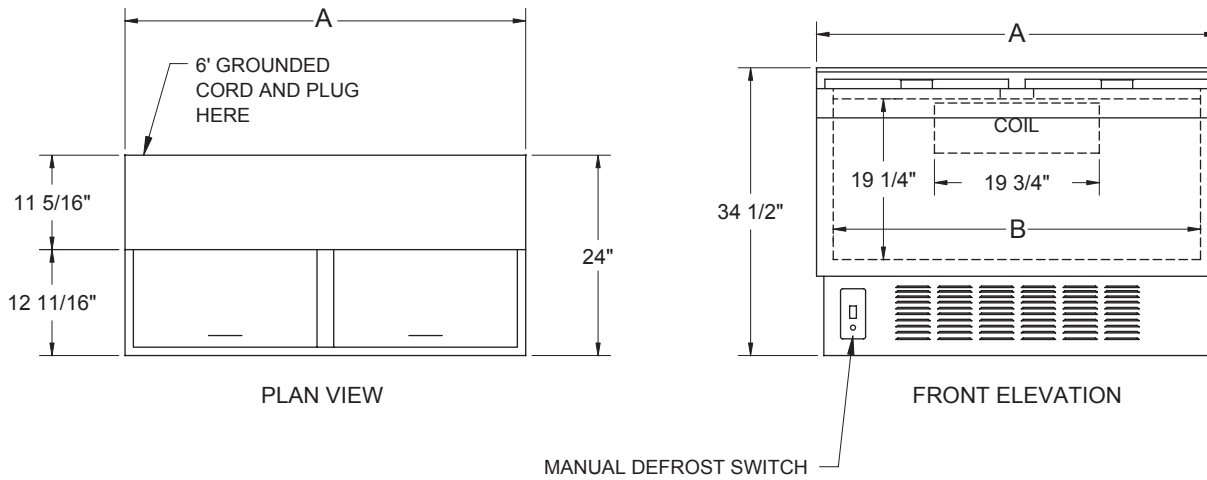

TYPICAL END VIEWS