



Project Name: _____ AIA#: _____ Model #: _____

Location: _____ SIS#: _____ Item #: _____ Quantity: _____



3850NF Premium Heavy-Duty Automatic Frozen Meat Slicer

Premium Model:
 3850NF Two Speed Auto Slicer
Frozen Meat Slicer



Made in the U.S.A.

GLOBE FOOD EQUIPMENT COMPANY

Premium Heavy-Duty Automatic Frozen Meat Slicer 3850NF

**Certified by NSF International to go above and beyond standard performance!
NSF ANSI 8 2010 Standard**

Premium Construction

- 13" PreciseEdge™ hardened steel alloy serrated knife with maximum tip-edge-holding ability and slices frozen meats with precision
- Exclusive stainless steel construction, with superior corrosion resistance against acids found in fruit, meats and vegetables
- Best of the Best, EZ-Glide™ table
- No-drip base with Marine edge redirects liquids to center of base away from controls and operator
- Precise slice-thickness adjustment, one-piece handle, gear driven, and gasket-sealed
- Carriage angle: 45°, full gravity feed
- 2° angled drip groove on the slicer table directs the flow of liquids to the base
- 12" long chute with 3 lb. stainless steel end weight
- Powerful 1/2 HP, 7 amp continuous use motor
- High-performance gear knife drive
- Maintenance-free drive system
- Permanently attached knife ring guard with removable slice deflector

Food Zone Features

- Large stainless steel radii, open space base design for cleaning and simple dismantling of components
- Base has a Marine edge from 1/2" to 3/4" wide and indented areas with 3/16" deep radiused transition and 3/16" deep internal covered corners. Both are integral to the base's work surface
- Top-mounted knife cover is removable and BPA Free (no-bisphenol-A), immersible, and dishwasher-safe for cleaning and sanitizing
- Moisture proof, easy-to-clean direct contact start/stop touchpad controls
- Sealed splash zones for added sanitation and protection of electronics

Operator Protection Features

- No voltage release prevents inadvertent reactivation of slicer in the event of power or interlock interruption
- Knife cover interlock prevents slicer from operating without the knife cover in place
- Permanent knife blade ring guard, removable cover, and deflector
- Touch pad start/stop controls and power indicator light
- Ergonomic low-profile design reduces operator fatigue
- Dual arm lift lever for cleaning and sanitizing under the slicer



GLOBE FOOD EQUIPMENT COMPANY
2153 Dryden Rd., Dayton, OH 45439
Phone: 937-299-5493 Fax: 937-299-4147
800-347-5423
www.globeslicers.com

Approved By: _____

Date: _____



Premium Heavy-Duty Automatic Frozen Meat Slicer 3850NF

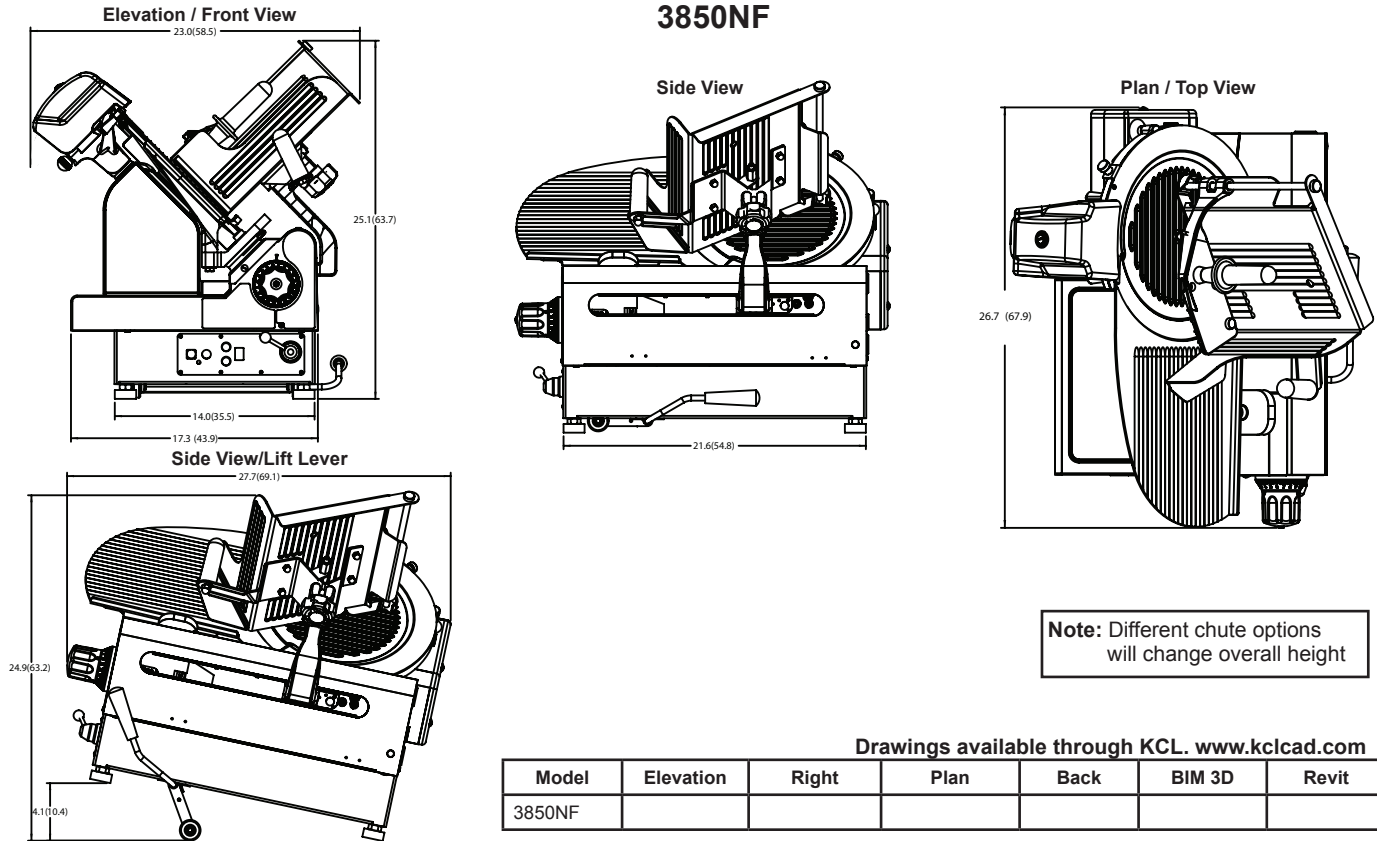

SPECIFICATIONS

Model	Auto or Manual	Motor	Volts	Amps	Drive Type	Slicing Volume per Day	Cheese Slicing	Blade Diameter	Max Slice	Product Cutting Capacity D (Diameter)	W (Width)	H (Height)
3850NF	Both	1/2 HP	115-60-1	7	Gear	All Day		13" (33.02 cm)	1-1/4" (3.18 cm)	7.5" (19.50 cm)	11.6" (29.46 cm)	9" (22.86 cm)

Cord & Plug: Attached 7 foot flexible 3-wire cord with molded plug fits a grounded receptacle. NEMA 5-15

FACTORY INSTALLED OPTIONS:

- Quick-Clean™ proprietary non-stick nickel-based coating (knife cover and slice table)
- Correctional package
- 15" long food chute
- 13" stainless steel knife

SLICER ENHANCEMENT ACCESSORIES:

- Stainless steel low food fence (12" L x 1 3/8" H)
- Stainless steel high food fence (12" L x 3" H)
- 7" D x 14" L Stainless steel vegetable hopper
- Clear plastic slicer cover (Tip: Recommended for preconstruction)
- Additional cleaning brush

WARRANTY:

- 15 years on the knife drive gears
- Two-years parts
- One-year labor

Warranty valid in North America. Contact factory for warranty in other countries

DIMENSIONS & SHIPPING INFORMATION

Freight Class 77.5

Cartons are reinforced for shipping. The weight and dimensions of this reinforced carton are included below, may vary from shipment to shipment and may include the weight from an attached skid.

Model	Foot Print	Overall Dimensions	Net Weight	Shipping Dimensions	Shipping Weight
3850NF	14" D x 21.6" W (35.5 cm x 54.8 cm)	26.7" L x 23" W x 25.1" H (69.7 cm x 58.5 cm x 63.7 cm)	145 lbs. (67.1 kg)	28" L x 25" W x 34" H (71.1 cm x 63.5 cm x 86.4 cm)	172 lbs. (78 kg)



GLOBE FOOD EQUIPMENT COMPANY

www.globeslicers.com

2153 Dryden Rd.
Dayton, OH 45439
Phone: 937-299-5493
Phone: 800-347-5423
Fax: 937-299-4147