



SMARTSTEAM PRO

BOILERLESS STEAMER ELECTRIC MODEL GSSP-BL-3E/ES

Stainless steel, boilerless convection steamer with a self-contained atmospheric 9 KW electric steam generating 2.5-gallon reservoir.

PROJECT NAME:	
LOCATION:	
ITEM NO:	
QTY:	
MODEL NO:	
AIA NO:	
SIS NO:	
CSI SECTION:	

SHORT FORM SPEC: Shall be a Groen SmartSteam Pro model GSSP-BL-3E/ES boilerless electric convection steamer (_____volt, _____phase). Rear-panel vents. The GSSP-BL-3E is a counter top steamer and the GSSP-BL-3ES comes fully assembled from the factory on a stainless steel stand. Water-resistant touchscreen control with self-diagnostics and programmable features. Capacity to be (3) 12"x20"x2-1/2" hotel pans. Dual water connection per cavity, auto fill and drain, mirrored interior, side-mounted convection fan. 2.5-gallon water reservoir protected by removable steam lid for easy cleaning and increased steam recovery. Slammable, field-reversible, hands-free stainless steel door latch. Standard 1-year parts and labor warranty with additional 1-year warranty upon completion of scheduled free Groen startup. 5-year cavity warranty. Made in the U.S.A.

AVAILABLE MODELS:

- GSSP-BL-3E (table top)
- GSSP-BL-3ES (stand-mounted)

CONSTRUCTION:

- Stainless steel construction with removable non-louvered side panels
- Rear-panel vents for decreased water/spray ingress
- Stainless steel field-reversible door with continuous hinge and single-piece replaceable seal
- Hands-free door latch provides positive closure when pushed or slammed shut
- Hidden door switch cuts power to blower fan and steam generating reservoir when door is opened
- Pan support racks are stainless steel and easily removed for cleaning
- Removable stainless steel condensate tray located under cavity door
- 5-year cavity warranty
- ASA component control (fan, valve, etc.) allows visibility of component operation on screen
- USB port for service use and firmware updates
- 7-day storage of error code history

FINISH: Cabinet exterior and door feature a #3 uniform finish. Cavity interior is polished stainless steel with mirrored finish.

UL & CUL LISTING: Steamer is UL and cUL listed.

SANITATION: NSF Listed. Designed and manufactured to meet all known health codes.

CONTROLS:

- Water resistant, user-friendly touch screen
- Self diagnostics
- User selected or automatic holding feature after timed cook completes
- 10 nameable pan timers
- Door open alert

- Clock
- Programmable delime schedule with simple on-screen walk-through and notifications
- "+1 minute" button quickly adds to cook time
- User optional load compensating timer

PERFORMANCE FEATURES:

- Powerful, side-mounted blower increases steam velocity for efficient distribution throughout cavity and between loaded pans
- 3.0 KW of electric power input per 2-1/2" deep steam pan
- Removable steam lid increases recovery times and aids in ease of cleaning
- Typical heat up is zero to ready in 15 minutes or less
- Cavity maintains warmth and ready status for instant steam between loads

ATMOSPHERIC STEAM RESERVOIR:

- High-efficiency electric-heated steam generating reservoir provides atmospheric steam to the cavity at a temperature of approximately 212°F
- Built-in water sensing system
- Electric heating elements are not immersed in water and are replaceable from the rear

PAN CAPACITY:

Pan Size/Type	Total
12 x 20 x 1"	6
12 x 20 x 2-1/2"	3
12 x 20 x 4"	2

INSTALLATION: Steamer requires 208, 240, or 480 Volt, 3-phase electrical service. Each cavity has (2) 3/4" NH cold water supply line connections and a single 1-1/2" free venting drain connection. All units ship three-phase, and are field convertible to single-phase operation.

CONTINUED ON BACK...

OPTIONS/ACCESSORIES:

- Prison Package
- Field Drain Tempering Kit
- Stainless Steel Stand
- Pan Rack Kit for Stand
- Flanged Foot Kit for Stand
- Caster Kit for Stand
- 4" Adjustable Legs (GSSP-BL-3E only)
- Heat Shield Kit (field installed)
- Water Treatment Systems
- Water Treatment Replacement Cartridges
- 1-Year Warranty Extension

ADDITIONAL RESOURCES:

[Request A Quote](#)
[Sales Tools](#)
[Find A Rep](#)

WATER QUALITY REQUIREMENTS:

- Containment
- Water Supply
- pH
- 7 to 9
- Total Dissolved Solids (TDS)
- 30 to 60 ppm
- Hardness
- less than 60 ppm
- Chlorine and Chloramine
- less than .1 ppm
- Chlorides
- less than 30 ppm
- Silica
- less than 12 ppm
- Undissolved Solids
- less than 5 microns

In order to accurately choose the correct water treatment solution, a water quality test has to be performed. If a "Free Start-up" is requested, the ASA will perform a water quality test and Unified Brands will be able to suggest the best solution for your water quality. If a "Free Start-Up" was not requested prior to installation, then your local manufacturing representative can coordinate this for you.

After the "Free Start-up" is performed, Unified Brands will add an additional 1-year parts and labor warranty. If Unified Brands suggests a water treatment system, the system is purchased from Unified Brands, installed and maintained, water related service issues will be covered for the duration of the warranty period.

ORIGIN OF MANUFACTURE:

Designed and manufactured in the United States.

SERVICE CONNECTIONS & NOTES:

- ① DRAIN CONNECTIONS: 1 1/2" [38] TUBE FREE VENTING DO NOT CONNECT DIRECTLY TO DRAIN. ALLOW 2" [51] AIR GAP
- ② WATER SUPPLY: (2) 3/4" [19] MALE HOSE CONNECTION. 30-60 PSIG WITH A FLOW RATE OF 1.50 GPM. ONE EACH MAIN & CONDENSATE, PRESSURE REGULATOR REQUIRED FOR WATER PRESSURE OVER 60 PSI
- ③ ELECTRICAL CONNECTION: SEE CHART CONDUIT HOLE SIZE: 1-1/4" [32] HOLE

ELECTRICAL REQUIREMENTS			
VOLTAGE	PHASE	AMPS	MAX. KW
208	1	44	9
	3	25	9
240	1	38	9
	3	22	9
480	3	11	9

ALL UNITS 60Hz

- ④ CLEARANCES:
EACH SIDE = 2" [51]
REAR = 6" [152]
- ⑤ DIMENSIONS IN BRACKETS [] ARE MM.
- ⑥ STEAM FREE ZONE: STEAMERS FLOOR DRAIN NOT TO BE LOCATED WITHIN ZONE. ALTERNATE EQUIPMENT THAT DRAIN CAUSING STEAM NOT TO BE DRAINED IN STEAM FREE ZONE
- ⑦ DO NOT INSTALL STEAMER DIRECTLY ABOVE STEAM VENTING FLOOR DRAINS
- ⑧ STEAM EXHAUST

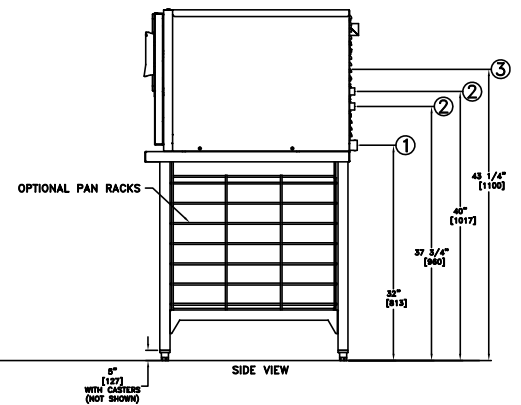
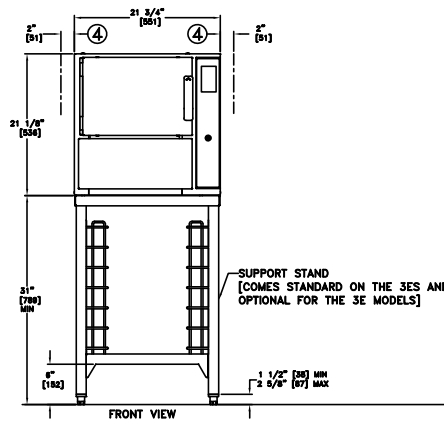
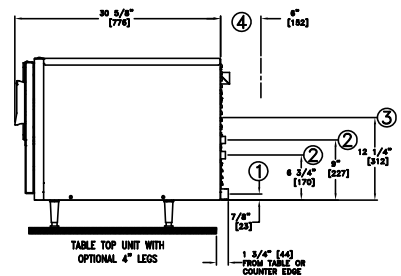
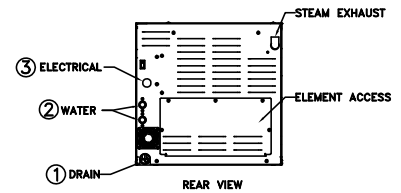
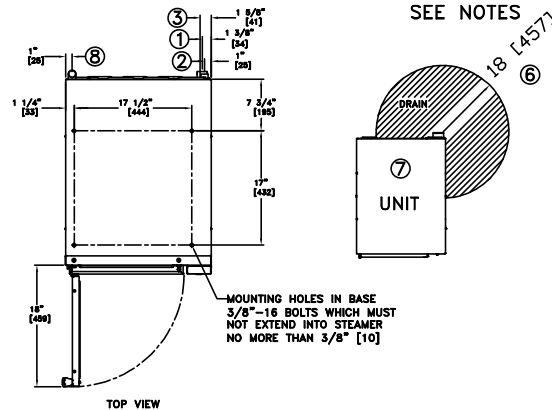

GSSP-BL-3E/ES 179246 REV. A