

Rear Loading 35E Series Open Merchandisers 78.5"H – Endless Design - Multi-purpose



HOWARD McCRAY Announces the New REAR LOADING 35E Series Open Merchandiser.

Building on the Popularity of our 35E Multipurpose design, we are adding the functionality and convenience of REAR-LOADING doors. The OD35E models are 78.5" in height and are available in 38", 51", 63" & 75" lengths. The maximum depth of 33" makes for easy delivery thru standard doorways. The 38" & 51" Models are available with swing doors, 51", 63" & 75" lengths feature sliding doors.

MODEL NUMBERS

Model No.	Description	Length	Depth	Height	Voltage	Amps	HP/BTUs	Power Cord	Est. Ship Weight
SC-OD35E-3-SW-B	Self Contained	39.00"	36.50"	78.50"	115	12.0	1/2	5-15P	700
SC-OD35E-4-SW-B	Self Contained	51.00"	36.50"	78.50"	115	13.7	3/4	5-20P	965
SC-OD35E-4-SL-B	Self Contained	51.00"	34.50"	78.50"	115	13.7	3/4	5-20P	965
SC-OD35E-5-SL-B	Self Contained	63.00"	34.50"	78.50"	115/208-230	13.1	1	L14-20P	1175
SC-OD35E-6-SL-B	Self Contained	75.00"	34.50"	78.50"	115/208-230	13.1	1	L14-20P	1175
R-OD35E-3-SW-B	Remote	39.00"	36.50"	78.50"	115	1.4	4906	NO	575
R-OD35E-4-SW-B	Remote	51.00"	36.50"	78.50"	115	2.2	6542	NO	790
R-OD35E-4-SL-B	Remote	51.00"	34.50"	78.50"	115	2.2	6542	NO	790
R-OD35E-5-SL-B	Remote	63.00"	34.50"	78.50"	115	2.8	8178	NO	895
R-OD35E-6-SL-B	Remote	75.00"	34.50"	78.50"	115	2.8	9813	NO	895

STANDARD SPECIFICATIONS AND OPTIONAL FEATURES

CONSTRUCTION

- UL Classified to ANSI/NSF 7
- Foamed in place CFC free foam
- Heavy gauge steel super structure
- Multi deck
- Endless design

INTERIOR

- Black end panels
- Removable Black floor pans
- Black perforated rear wall for even air distribution (swing door only)
- Full length lighting at top of unit
- 4 levels of lit shelving
- 5 levels of product display
- Stylish tag molding on each shelf
- Mirrored client view on slider models

EXTERIOR

- Black ends and front and back
- Black rear doors (hinged units)
- Removeable front grill allows for cleaning and servicing
- 1" bumper
- Choice of end panels

FINISHES

- Black front rail
- Black end trim
- Black end panels
- Black rear panels
- Laminate, and custom paints available

LIGHTING

- 1 row LED at inside top of unit
- 4 rows of LED lighted shelving

ELECTRICAL REQUIREMENTS

- Unit comes with cord and plug
- UL/CUL listed
- See Tech page for details on voltage

REFRIGERATION

- Self Contained expansion valve system
- Remote expansion valve system
- Low velocity fans located below deck area (to insure even flow of air)
- Electronic Control System with automatic air defrost to maintain balanced temperatures
- New high efficiency air screen technology
- Self contained system
- Hermetic unit
- Remotes available

OPTIONAL FEATURES

- **NEW** Sliding and Hinged Rear Access Doors
- Night covers
- Colored bumper
- Stainless steel, laminated or paint
- Product stops on shelving
- Digital thermometer
- Casters or legs
- Evaporator Pan

MODEL NUMBER PREFIX: SC = Self Contained R = Remote

MODEL NUMBER SUFFIX: B = Black

SW = Swinging Door, SL = Sliding Door

- Cases are designed to operate at 75 degrees Fahrenheit and 55% relative humidity
- Cases are equipped with drains; check your local building codes for connection requirements.
- Specification subject to change without notice

IF COLORS ARE MIXED AN ADDITIONAL CHARGE WILL APPLY



TECHNICAL DATA

Model No.	SC R	SC-OD35E-3-SW-B R-OD35E-3-SW-B	SC-OD35E-4-SW-B R-OD35E-4-SW-B	SC-OD35E-4-SL-B R-OD35E-4-SL-B	SC-OD35E-5-SL-B R-OD35E-5-SL-B	SC-OD35E-6-SL-B R-OD35E-6-SL-B
Length with (2) ends		39.00"	51.00"	63.00"	75.00"	75.00"
Length without ends		36.00"	48.00"	48.00"	60.00"	72.00"
Height with ends		78.50"	78.50"	78.50"	78.50"	78.50"
Height without ends		78.00"	78.00"	78.00"	78.00"	78.00"
Depth with ends		36.50"	36.50"	34.50"	34.50"	34.50"
(Swing Door Open)		64.75"	76.75"			
Depth without ends		34.25"	34.25"	34.25"	34.25"	34.25"
(Swing Door Open)		64.25"	76.25"			
Endless design		YES	YES	YES	YES	YES
(Dimensions are +/- 1/4")						
Operating temperature		36°F to 40°F	36°F to 40°F	36°F to 40°F	36°F to 40°F	36°F to 40°F
Refrigerant (expansion valve)	SC	R448A	R448A	R448A	R448A	R448A
Refrigerant (expansion valve)	R	R448A	R448A	R448A	R448A	R448A
Compressor size HP	SC	1/2	3/4	3/4	1	1
Defrost per day (24 hrs)	Air Defrost	6 per day	6 per day	6 per day	6 per day	6 per day
BTU's at +20°F Evap Temp	R	4906	6542	6542	8178	9813
Voltage	SC	115	115	115	115/208-230	115/208-230
Amperage	SC	16	13	13	16	16
Remote Voltage	R	115	115	115	115	115
Amperage, lights & fans only	R	2.0	3.0	3.0	4.0	4.0
Cord and plug	SC	5-15P	5-20P	5-20P	L14-20P	L14-20P
	R	NO	NO	NO	NO	NO
Exterior color		Black	Black	Black	Black	Black
Interior color		Black	Black	Black	Black	Black
# of rows / shelves		4/4	4/4	4/4	4/4	4/8
Shelf size depth		(4) 18.0"	(4) 18.0"	(4) 18.0"	(4) 18.0"	(8) 18.0"
Shipping Info						
Height		86.00"	86.00"	86.00"	86.00"	86.00"
Depth		44.00"	44.00"	44.00"	44.00"	44.00"
Length		61.00"	61.00"	61.00"	86.00"	86.00"
Gross weight SC/R		700/575	965/790	965/790	1175/895	1175/895
Cubic feet		130	130	130	184	184

TECHNICAL DATA VIEWS

Side View

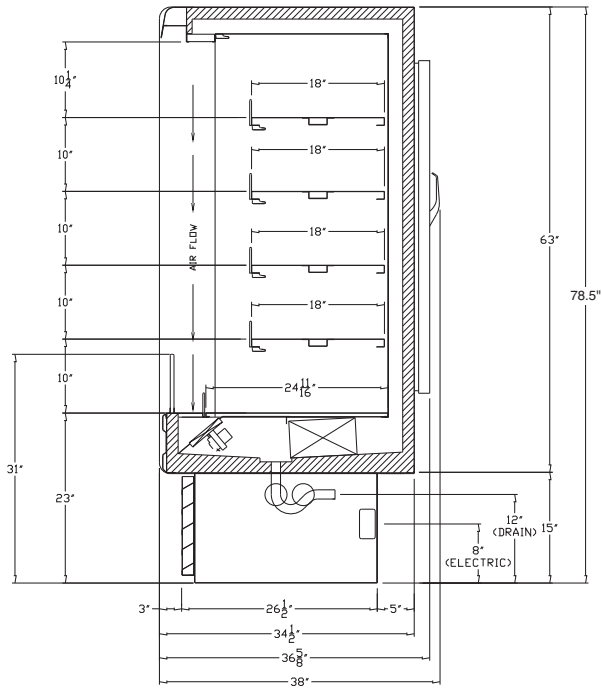

Rear View (Open & Closed)

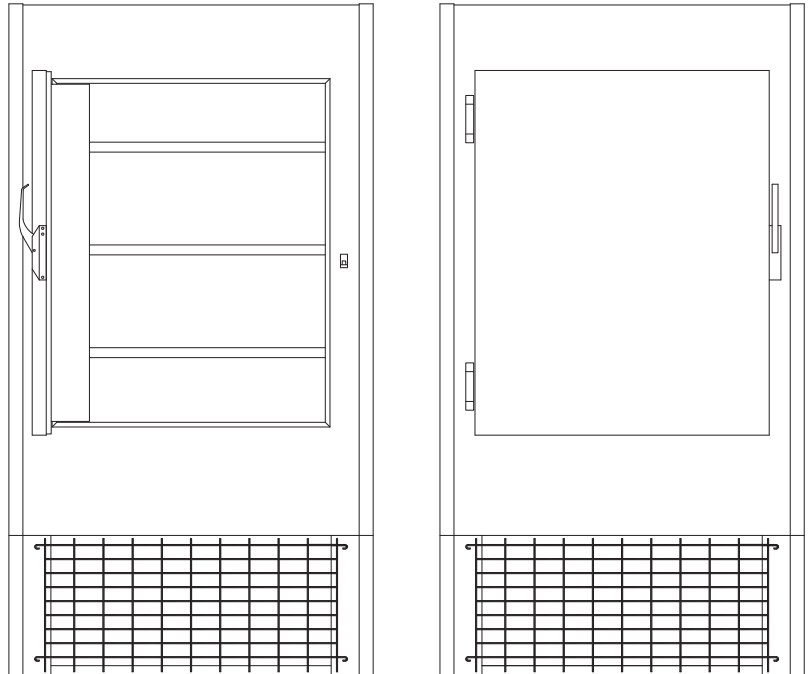

Plan View (3' & 4')

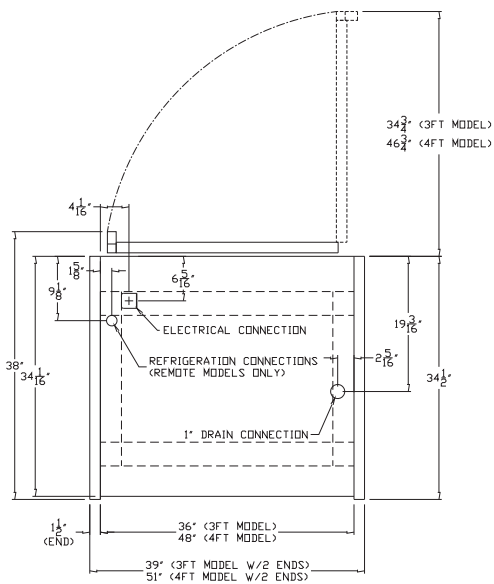

Plan View (5' & 6')

