



Project \_\_\_\_\_  
 AIA # \_\_\_\_\_ SIS # \_\_\_\_\_  
 Item # \_\_\_\_\_ Quantity \_\_\_\_\_ C.S.I. Section 114000



# 84186

## Food Cutter



### SPECIFIER STATEMENT

Specified unit will be an NSF rated Hobart food cutter with 1 HP motor and 15-pound capacity. Unit features a 18" removable stainless steel bowl, removable stainless steel knives with stainless steel knife comb and 3" stainless steel legs with rubber feet. Bowl rotates at 20 RPMs and knives rotate at 1725 RPM simultaneously to process ingredients. Correctional unit with tamper proof fasteners and locked on/off switch also available.

### MODEL

- 84186** Food cutter with 18" stainless steel bowl, double cutlery grade stainless steel knives with stainless steel knife comb and 3" stainless steel legs with rubber feet
- 84186C** Maximum security correctional package with tamper proof fasteners, lock on the on/off switch, and 115/60/1 with attachment hub only

### STANDARD FEATURES

- + 1 H.P. motor
- + 15-pound capacity
- + 18" stainless steel bowl
- + One-piece burnished aluminum housing
- + 1725 RPM knife rotation
- + Bowl cover interlock
- + 20 RPM bowl rotation
- + Double cutlery grade stainless steel knives
- + Pull/push on/off switch
- + 3" stainless steel legs with rubber feet
- + 6' flexible cord and plug

### ACCESSORIES

- Vegetable Slicer
- Meat Chopper Attachment

**84186 FOOD CUTTER**

Approved by \_\_\_\_\_ Date \_\_\_\_\_ Approved by \_\_\_\_\_ Date \_\_\_\_\_

## SOLUTIONS/BENEFITS

### PERFORMANCE

#### Double Cutlery Grade Stainless Steel Knives

- + Reduces food products to a uniformly small particle size for salads, spreads, breadcrumbs and other recipes
- + Holds an edge longer, resulting in fewer sharpenings

#### 1 H.P. Motor

- + Heavy-duty to meet the most demanding operations

### EASE OF USE

#### Bowl and Knife Rotation

- + Bowl rotates at 20 RPM and knife rotates at 1725 RPM for easy incorporation of ingredients

### SANITATION & CLEANING

#### Removable Bowl Cover, Knives, and Bowl

- + Easily removed without tools to be cleaned in a three-compartment sink

#### One-Piece Burnished Aluminum Housing

- + One-piece base has no cracks or crevices to allow food product to build up

### OPERATOR ASSURANCE

#### Bowl Cover Interlock

- + Machine cannot be turned on until the bowl cover is locked down into position
- + Bowl cover cannot be raised with the switch in the "ON" position

## SPECIFICATIONS

**Electrical:** 115/60/1, 230/60/1, 208/60/3 and 460/60/3 – UL listed. Also available in 230/50/1 – not submitted for UL listing.

**Motor:** 1 H.P., with permanently lubricated ball bearings and totally enclosed within the machine. Single-phase is capacitor start, induction-run type. Three-phase is polyphase squirrel-cage, induction-run type.

**Switches:** On/off switch is mechanically interlocked with bowl cover so that the switch cannot be operated unless bowl cover is locked down in position. On/off switch actuates a magnetic contactor.

**Cord and Plug:** 6 foot flexible cord with plug per NEMA configuration. Export models will be supplied with I.E.C. cord without plug.

**Bowl:** 18" inside diameter. Made of single piece of stainless steel, is easily removed for cleaning. Rotates at 20 RPM.

**Bowl Cover:** One-piece burnished aluminum casting, carefully fitted to the top of the bowl. It can be lifted to remove material from the bowl and can be removed for easy cleaning.

**Knives:** Rotate at 1725 RPM. The blades (made of special cutlery grade stainless steel) are secured to a hub as a unit, which may be removed from the knife shaft without change of knife clearance adjustment. Stainless steel knife comb included.

**Base:** One-piece burnished aluminum casting with plated steel bottom cover (total enclosure).

**Standard Equipment:** Consists of Food Cutter with 18" stainless steel bowl, cutlery grade stainless steel knives with stainless steel knife comb and 3" stainless steel legs with rubber feet.

**Attachment Hub:** Speed – 256 RPM. Accommodates all Hobart No. 12 attachments.

**Accessories:** Vegetable Slicer and Meat Chopper Attachment.

**Warranty:** Unit has full one-year warranty on parts, labor and mileage against manufacturer's defects. Service contracts are available.

**Weight:** Shipping – 185 lb.; Net – 140 lb.

### Plugs and Receptacles:

Dependent on local power codes

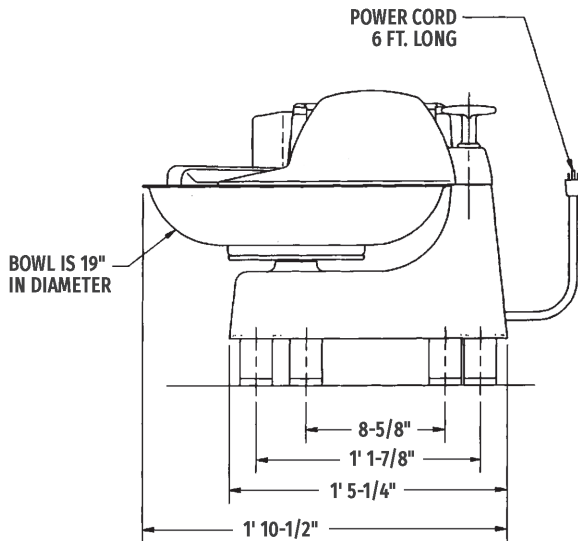

	Machine Voltages				
	84186	120/60/1	230/60/1	200-208	460/60/3
Service Current Requirement if Plug Connected	120/60/1	230/60/1	200/60/3	208/60/3	460/60/3
	15 Amp.	15 Amp.	20 Amp.	20 Amp.	
Terminal Designation of Plug	2 Pole 3 Wire Grdg.	2 Pole 3 Wire Grdg.	4 Pole 5 Wire Grdg.	3 Pole 4 Wire Grdg.	
NEMA Plug Configuration	5-15P	6-15P	L21-20P	L16-20P	
Plug Configuration					
Molded Plug on Cord	Yes	Yes	No	No	
Plug - Straight/Angle	Straight	Straight	Straight	Straight	
NEMA Receptable or Connector Configuration	5-15R	6-15R	L21-20R	L16-20R	
Power Cord Included	Yes	Yes	Yes	Yes	

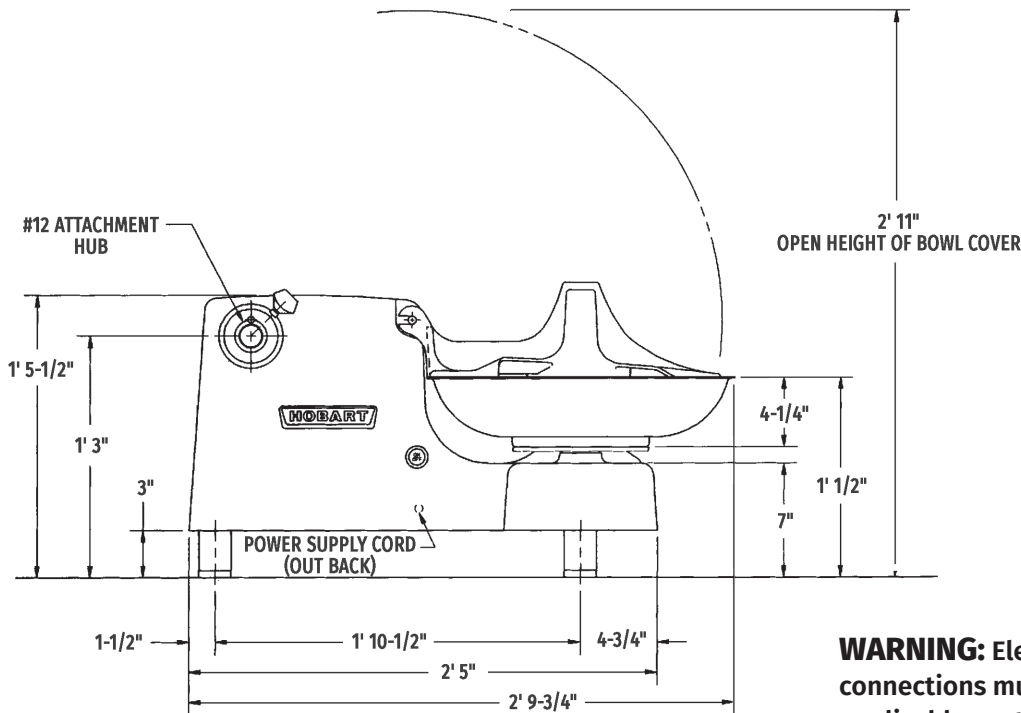

**NOTE:** If the machine is to be installed without legs the base must be sealed to the supporting surface for NSF approval.

**WARNING:** Electrical and grounding connections must comply with the applicable portions of the National Electrical Code and/or other codes in force.

MODEL:  
84186  
D-291772-1  
REV B