



# KM-81/116BAK

**SELF-CONTAINED CUBER  
WITH BUILT-IN STORAGE BIN**

**KM|EDGE™**



KM-81/116BAK  
05/20/26  
Item # 13552K

**W x D x H**  
**17<sup>3</sup>/<sub>4</sub>" x 24" x 38<sup>5</sup>/<sub>8</sub>"\***  
\*including 6" legs

**W x D x H**  
**23<sup>3</sup>/<sub>4</sub>" x 24" x 38<sup>5</sup>/<sub>8</sub>"\***  
\*including 6" legs

**ADA Compliant**

**KM-81BAK ★**  
Air-Cooled

**KM-116BAK ★**  
Air-Cooled



## Features

- ▶ Individual crescent cube
- ▶ Environmentally friendly R290 hydrocarbon refrigerant
- ▶ Stainless steel evaporator

### KM-81BAK

- Up to 98 lbs. of ice production per 24 hrs
- Built-in storage capacity of 1.3ft<sup>3</sup>/38 lbs.\*

### KM-116BAK

- Up to 130 lbs. of ice production per 24 hrs
- Built-in storage capacity of 1.8ft<sup>3</sup>/53 lbs.\*

- CycleSaver™ design
- Durable stainless steel exterior
- Front-in, front-out airflow with removable air filter
- Slide in door
- Power switch accessible without panel removal
- Built-in installation possible
- 6.5 ft. (2000 mm) power cord with NEMA 5-15P plug
- EverCheck™ alert system
- *Optional Drain pump assembly - HS-5061*

**Warranty:** 3 Year Parts & Labor on entire machine. 5 Year Parts & Labor on Evaporator. 5 Year Parts on Compressor; air-cooled condenser coil. 1 Year - HS-5061 Drain Pump Assembly - Parts & Labor. Valid in United States, Canada, Puerto Rico and U.S. Territories. Contact factory for warranty in other countries.

\*Rated in accordance with AHRI Standard 820(I-P). Capacity based on 100% of total volume x 30 lb/ft<sup>3</sup> average density of ice.

### ICE PRODUCTION      WATER USAGE      ELECTRICAL

Condenser	Model	Air / Water Temp Lbs. per 24 hours		Potable Gal. per 100 lbs. 90° / 70°F	Condenser Gal. per 100 lbs. 90° / 70°F	kWh Used per 100 lbs. 90° / 70°F	Min. Circuit/Max. Fuse Size	Amperage	Voltage	Heat Rejection BTU/hr.	Refrigerant Charge Amount	Net / Ship Weight (lbs.)
		70° / 50°F	90° / 70°F									
Air-Cooled	KM-81BAK	98	76	22.0	N/A	5.6	15A	2.4A	115V/60/1	1,800	3.0 oz.	92 / 125
Air-Cooled	KM-116BAK	130	110	20.0	N/A	5.2	15A	3.4A	115V/60/1	2,500	3.2 oz.	111 / 146

KM-81BAK Shipping: (LxWxH) 27" x 21" X 39"    Volume: 12.80ft<sup>3</sup>

KM-116BAK Shipping: (LxWxH) 27" x 27" X 39"    Volume: 16.45ft<sup>3</sup>

## KMEdge™ Cube Dimensions\*

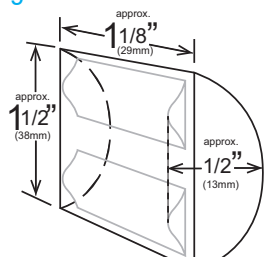

\* approximate size in inches, image not to scale

## Operating Limits

- Ambient Temp Range 45 - 100°F
- Water Temp Range 45 - 90°F
- Water Pressure 10 - 113 PSIG
- Voltage Range 108 - 122V
- If GFCI is required, a GFCI breaker MUST be used in lieu of GFCI receptacle

## Service

- Allow enough space at rear for water supply and drain connections, at least 12" (30 cm) clearance at front and at least 0.6" (15 mm) clearance at top for maintenance.

## Plumbing

- Icemaker Water Supply Line: Minimum 1/4" Nominal ID Copper Water Tubing or Equivalent
- Icemaker Drain Line: Minimum 3/4" Nominal ID Hard Pipe or Equivalent

## Water Filter

Please refer to water filter spec sheet for recommended configurations.

Hoshizaki reserves the right to change specifications without notice.



# KM-81/116BAK

**SELF-CONTAINED CUBER  
WITH BUILT-IN STORAGE BIN**

**KM|EDGE™**

KM-81/116BAK  
05/20/26  
Item # 13552K

mm  
[inch]

**FRONT VIEW**

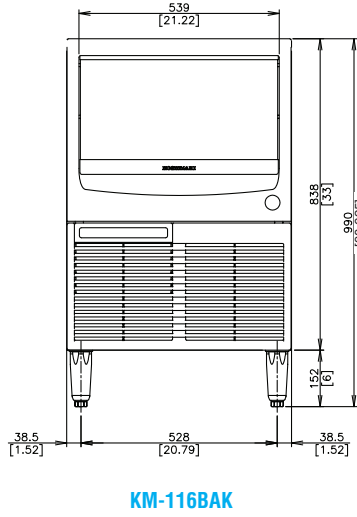
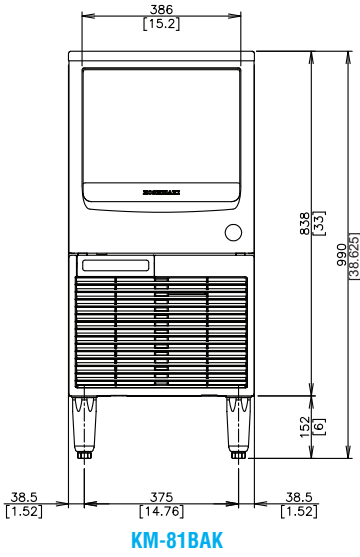

**TOP VIEW**

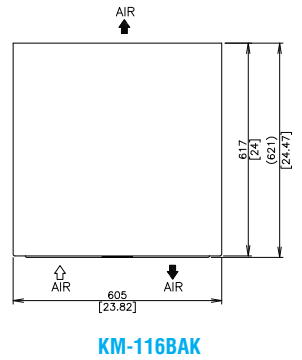
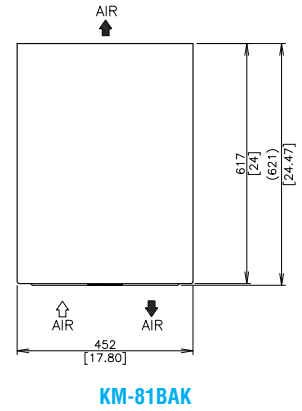

**SIDE VIEW**

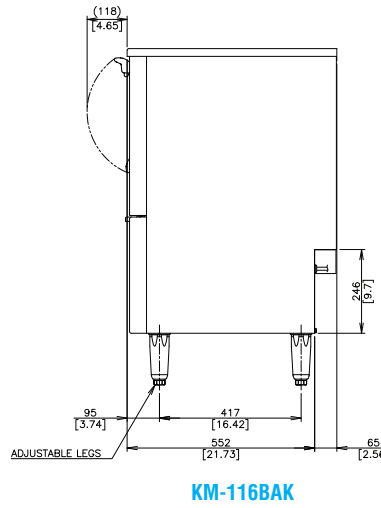
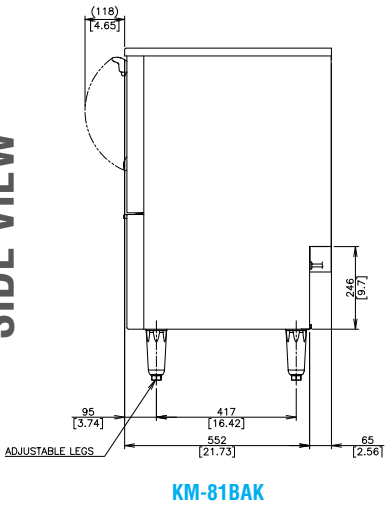

**REAR VIEW**

