



# UF48B-LP

## Undercounter 48" Low Profile Freezer with Two Doors



UF48B-LP  
10/29/24  
Item # 13722

### W x D x H

48" x 30" x 31.9"\*  
\*with 2.25" casters

Item #: \_\_\_\_\_

Project: \_\_\_\_\_

Qty: \_\_\_\_\_

AIA#: \_\_\_\_\_



## Features

- ▶ Specifically designed to fit under an ADA compliant 34" work surface height counter 
- ▶ Engineered to maintain NSF-7 temperatures in 100°F ambient
- ▶ Stainless steel exterior front, sides and top with stainless steel interior sides, back, and floor

- Environmentally friendly R290 hydrocarbon refrigerant
- Cabinet and door are insulated with 2" of CFC free, foamed in place polyurethane
- Innovative air distribution system distributes air evenly to maintain product temperature
- Exclusive "stepped" door design to protect door gasket
- Spring assisted self-closing door with stay open feature
- Extruded aluminum flush mount door handle
- Magnetic door gasket is easily removable for cleaning
- Hot gas condensate removal
- E-coated evaporator coil
- Anodized aluminum shelf supports adjustable in 1/2" increments
- Standard with 2.25" casters (two with brakes)
- 10 ft. cord and plug



### Dimensions / Capacity

### Two-Section UF48B-LP

Interior Storage Capacity (CF) (AHAM)	12 ft <sup>3</sup>
Overall Width x Depth (including 1" bumper)	48" x 31"
Height (including 2.25" casters)	31.9"
Door Opening Width x Height	19.5" x 23"
Depth with Door Open at 90° (including 1" bumper)	51.5"
Adjustable Shelves	2
Shelf Dimensions (W x D)	21.5" x 16"
Crated Shipping Weight	258 lbs.
Crated Length x Width x Height	52.5" x 34" x 35.5"

### Electrical / Refrigeration

### Two-Section UF48B-LP

Voltage	115/60/1
HACR Breaker	15.0 Amps
Electrical Connection (NEMA)	5-15P 
Voltage Range	104-126
Ambient Temp. Range	45° to 100°F
Control Setpoint Range	-18° to 10°F
Amperage	3.6
Energy Consumption (kWh/day) @ASHRAE	3.60
Heat Rejection (BTU/Hr.) @NSF	756
Approx. Nominal Compres. BTU/HR (HP)	1426(1/3+HP)
Refrigerant / Charge Amount (oz)	R290 (2.6 oz)

### Options

- 4" Casters (HS-5035, set of 4)
- 6" Casters (HS-5036, set of 4)
- Foot pedal kit (HS-5555, Lft hinge)
- Foot pedal kit (HS-5556, Rt hinge)
- Door locks (UR48B-LP01)
- Overshelves (HS-5173 single)
- Overshelves (HS-5164 double)
- Addt'l epoxy shelves (HS-5059)
- Addt'l stainless shelves (HS-5117)
- Stainless steel back panel (factory request)



Valid in United States, Canada, Puerto Rico and U.S. Territories. \*Please visit [hoshizakiamerica.com/support/warranty/](http://hoshizakiamerica.com/support/warranty/) for more information.

If GFCI is required, a GFCI breaker MUST be used in lieu of GFCI receptacle

Hoshizaki reserves the right to change specifications without notice.



# UF48B-LP

Undercounter 48" Low Profile  
Freezer with Two Doors



UF48B-LP  
10/29/24  
Item # 13722

## FRONT VIEW

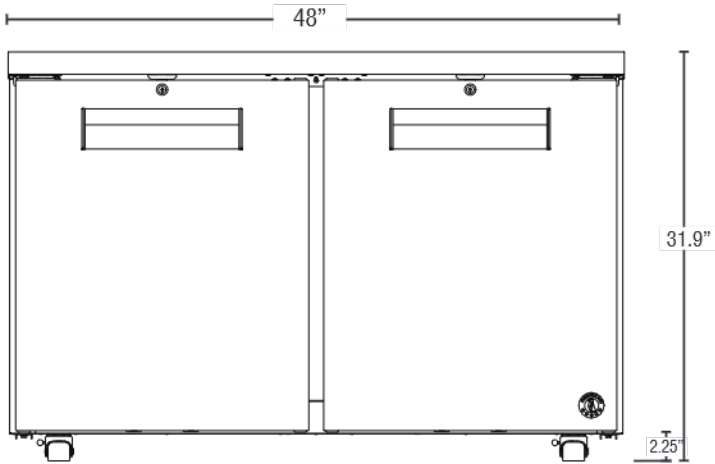

Front view shown with locks (UF48B-LP01)

## SIDE VIEW

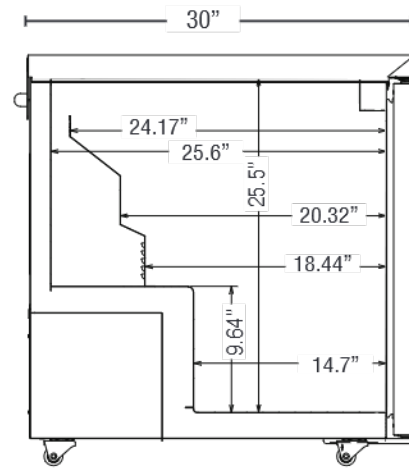

## PLAN VIEW

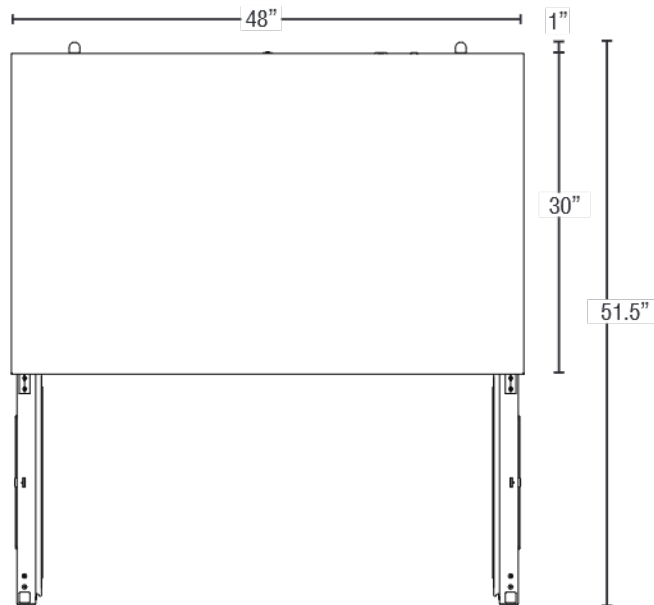

### Cabinet Construction

The exterior cabinet top, front, and sides, are constructed of high quality stainless steel. The exterior back and bottom are constructed of coated steel. The cabinet interior features stainless steel back, sides, and floor with an ABS top. One heavy duty epoxy coated shelf per section is standard. Mounted on anodized aluminum pilasters the shelves are adjustable in 1/2" increments. Cabinet walls are insulated with 2" CFC free, foamed in place polyurethane. 2.25" polyolefin, stem casters (two with brakes) are standard.

### Door Construction

Doors are constructed of high grade stainless steel exterior with an ABS interior liner and are insulated with 2" CFC free, foamed in place polyurethane. Hoshizaki's exclusive "stepped" design protects the gasket while product is removed from the cabinet. Doors are provided with a one piece, extruded aluminum, flush mount handle. Spring assisted self-closing doors are equipped with a stay open feature past 90 degrees. Snap-in magnetic door gaskets are durable and easily removed for cleaning. Field reversible door hinging is standard.

### Refrigeration System

The high efficiency refrigeration system is self-contained with an E-coated evaporator for extended life. Condensate removal is accomplished with an energy efficient non-electric evaporation system. A capillary tube controls the flow of environmentally friendly R290 refrigerant through the evaporator. Unit uses a heated, time initiated defrost to eliminate any ice on the evaporator coil. 115 volt units are equipped with a ten foot cord and plug (20.0 amps or less).