



WLF67B

Worktop 67" Side Mount Freezer with Two Doors



WLF67B
11/15/24
Item # 13731

W x D x H

67" x 33.25" x 40.25"*
Work Height 36"*
*with 6" casters



Dimensions / Capacity

| | Two-Section WLF67B |
|---|-----------------------|
| Interior Storage Capacity (CF) (AHAM) | 19.97 ft ³ |
| Overall Width x Depth (including 1" bumper) | 67" x 33.25" |
| Height (including 6" casters) | 40.25" |
| Door Opening Width x Height | 22.5" x 23" |
| Depth with Door Open at 90° (including 1" bumper) | 57.75" |
| Adjustable Shelves | 4 |
| Shelf Dimensions (W x D) | 24.75" x 25.5" |
| Crated Weight | 354 lbs. |
| Crated Length x Width x Height | 70.75" x 35.75" x 40" |

Electrical / Refrigeration

| | Two-Section WLF67B |
|--------------------------------------|--------------------|
| Voltage | 115/60/1 |
| HACR Breaker | 15.0 Amps |
| Electrical Connection (NEMA) | 5-15P Ⓢ |
| Voltage Range | 104-126 |
| Ambient Temp. Range | 45° to 100°F |
| Control Setpoint Range | -10° to 10°F |
| Recommended Setpoint | 2°F |
| Amperage | 5 |
| Energy Consumption (kWh/day) @ASHRAE | 4.49 |
| Heat Rejection (BTU/Hr.) @NSF | 851 |
| Approx. Nominal Compres. BTU/HR (HP) | 2870 (1/2+HP) |
| Refrigerant / Charge Amount (oz) | R290 (2.8 oz) |

Options

- 2" Casters (HS-5037, set of 4)
- 4" Casters (HS-5035, set of 4)
- Foot pedal kit (HS-5555, Lft hinge)
- Foot pedal kit (HS-5556, Rt hinge)
- Pan slide rack (HS-5514)
- Overshelves (HS-5231 single)
- Overshelves (HS-5230 double)
- Addtl. Epoxy Shelves (HS-5151, 1pk)
- Addtl. Stainless Shelves (HS-5153, 1pk)



Valid in United States, Canada, Puerto Rico and U.S. Territories. *Please visit hoshizakiamerica.com/support/warranty/ for more information.

If GFCI is required, a GFCI breaker MUST be used in lieu of GFCI receptacle

Hoshizaki reserves the right to change specifications without notice.

Item #: _____

Project: _____

Qty: _____

AIA#: _____

Features

- ▶ Front breathing air flow design allows for 1" of rear wall clearance
- ▶ Stainless steel exterior front, sides, and top with stainless steel interior
- ▶ Engineered to maintain NSF-7 temperatures in 100°F ambient
 - Environmentally friendly R290 hydrocarbon refrigerant
 - Cabinet and doors are insulated with 2" CFC free, foamed in place polyurethane
 - Exclusive "stepped" door design to protect door gasket
 - Spring assisted self-closing doors with stay open feature
 - Extruded aluminum flush mount door handle
 - Field reversible doors with magnetic snap-in gaskets
 - Magnetic door gaskets are easily removable for cleaning
 - Removable air filter for easy cleaning
 - Hot gas condensate removal
 - Mullion heaters for reduced condensation
 - Digital temperature display
 - E-coated evaporator coil
 - Four epoxy coated shelves is standard
 - Shelves hold a full sized sheet pan & 120 lbs. capacity
 - Anodized aluminum shelf supports adjustable in 1/2" increments
 - Standard with 6" casters (two with brakes)
 - 10 ft. cord and plug



WLF67B

Worktop 67" Side Mount
Freezer with Two Doors



WLF67B
11/15/24
Item # 13731

FRONT VIEW

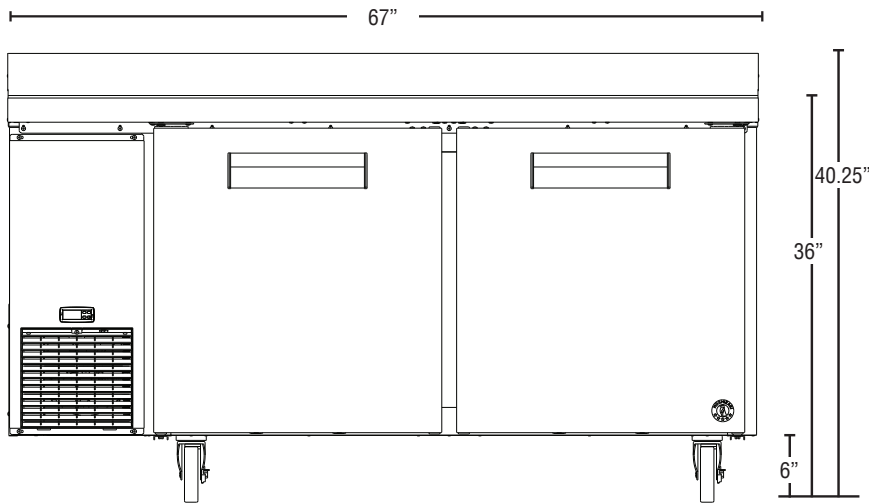

SIDE VIEW

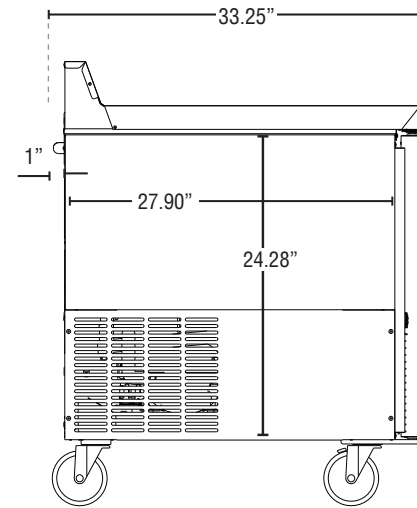

PLAN VIEW

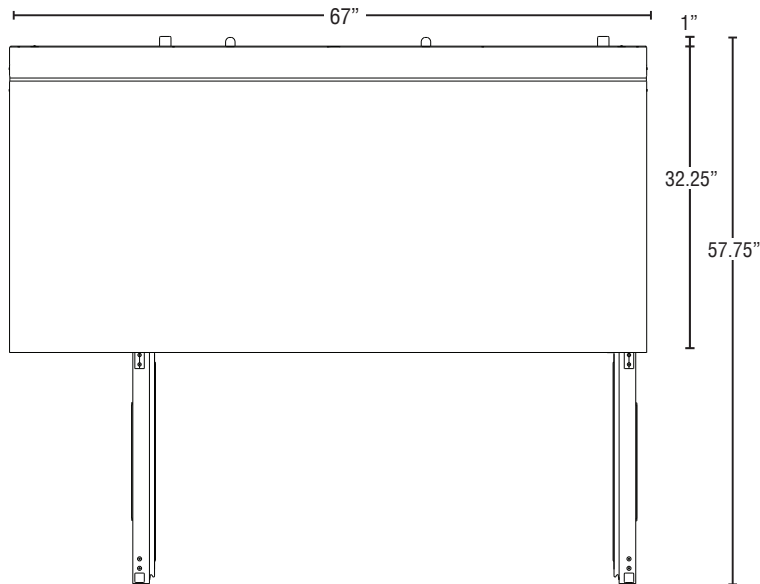

Cabinet Construction

The exterior cabinet top, front, and sides, are constructed of high quality stainless steel. The exterior back and bottom are constructed of coated steel. The cabinet interior features stainless steel back, sides, top and floor. Four heavy duty epoxy coated shelves is standard. Mounted on anodized aluminum pilasters the shelves are adjustable in 1/2" increments. Cabinet walls are insulated with 2" CFC free, foamed in place polyurethane. 6" polyolefin, stem casters (two with brakes) are standard.

Door Construction

Doors are constructed of high grade stainless steel exterior with an ABS interior liner and are insulated with 2" CFC free, foamed in place polyurethane. Hoshizaki's exclusive "stepped" design protects the gasket while product is removed from the cabinet. Doors are provided with a one piece, extruded aluminum, flush mount handle. Spring assisted self-closing doors are equipped with a stay open feature past 90 degrees. Snap-in magnetic door gaskets are durable and easily removed for cleaning. Field reversible door hinging is standard.

Refrigeration System

The high efficiency refrigeration system is self-contained with an E-coated evaporator for extended life. Condensate removal is accomplished with an energy efficient non-electric evaporation system. A capillary tube controls the flow of environmentally friendly R290 refrigerant through the evaporator. Unit uses a heated, time initiated defrost to eliminate any ice on the evaporator coil. 115 volt units are equipped with a ten foot cord and plug (20.0 amps or less).