

# HOSHIZAKI

Series

DB130/DB200  
Item # 13131 04/04

DB-130/DB-200 SERIES



**DB-130H**  
shown with a  
KM-280MAH



**DB-200H**  
shown with a  
KML-250MAH

**DB-130H**  
Hotel/Motel Ice Dispenser  
**DB-200H**  
Hotel/Motel Ice Dispenser

#### DB-130H

- Accommodates KM-280, KM-500 or KM-630 Series Cubers for 281 to 630 lbs. of ice per day
- Built-in 130 lbs. insulated polyethylene-lined ice storage bin
- Pushbutton, key or coin operated single auger agitator dispenses ice at 20 lbs. per minute

#### DB-200H

- Accommodates KML-250, KML-350, KML-450, KM-500 or KM-630 Series Cubers for 307 to 630 lbs. of ice per day
- Built-in 200 lbs. insulated polyethylene-lined ice storage bin
- Pushbutton, key or coin operated single auger agitator dispenses ice at 13 lbs. per minute



© HOSHIZAKI AMERICA, INC.

618 Hwy. 74 S., Peachtree City, GA30269

TEL1-800-438-6087



FAX 1-800-345-1325



www.hoshizaki.com

Reliability is a beautiful thing™

SANITARY CUBE DISPENSER

**SANITARY CUBE DISPENSER**

**DB-130H** Hotel/Motel Ice Dispenser  
**DB-200H** Hotel/Motel Ice Dispenser

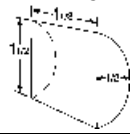

■ Pushbutton, key or coin operated single auger agitator dispenses ice at 20 lbs. (DB-130H) & 13 lbs. (DB-200H)



<p><b>WARRANTY</b> TWOYEAR - Parts &amp; Labor</p>	<p><b>SINGLE AUGER AGITATOR</b> To agitate and dispense ice at rate of 20 lbs. per minute for DB-130H &amp; 13 lbs. for DB-200H</p>	<p><b>VENDING</b> Pushbutton <i>Standard</i> Key, Card, or Coin Mechanism Kit <i>Optional</i></p>
--	---	---

Warranty valid in United States, Canada, Puerto Rico, & U.S. Territories. Contact Factory for Warranty in other Countries.

**STORAGE BINS**

**DB - 130H** – Insulated built-in 130 lb. capacity bin  
ARI rated capacity 90 lbs.  
**DB - 200H** – Insulated built-in 200 lb. capacity bin  
ARI rated capacity 140 lbs.

**OPERATING LIMITS**

Ambient Temp Range 45 - 100°F  
Voltage Range 104 - 127V

**ELECTRICAL**

**DB - 130H** – 115/60/1  
**DB - 200H** – 115/60/1

**NOTE: ICEMAKER SOLD SEPARATELY**  
Refer to Icemaker Spec Sheet for Icemaker connection diagram

SPECIFICATIONS			
Model Number	Dispensing gear motor	Amperage	Shipping Weight
DB-130H	60W	1.4	230 lbs.
DB-200H	60W	1.4	250 lbs.

**DB-130H Series**

Designed for use with:  
**KM-280M Series Cuber** - up to 269 lbs. ice production per 24 hours  
**KM-500M Series Cuber** - up to 517 lbs. ice production per 24 hours  
**KM-630M Series Cuber** - up to 619 lbs. ice production per 24 hours

**DB-200H Series**

Designed for use with:  
**KML-250M Series Cuber** - up to 307 lbs. ice production per 24 hours  
**KML-350M Series Cuber** - up to 358 lbs. ice production per 24 hours  
**KML-450M Series Cuber** - up to 447 lbs. ice production per 24 hours  
**KM-500M Series Cuber** - up to 517 lbs. ice production per 24 hours  
**KM-630M Series Cuber** - up to 619 lbs. ice production per 24 hours

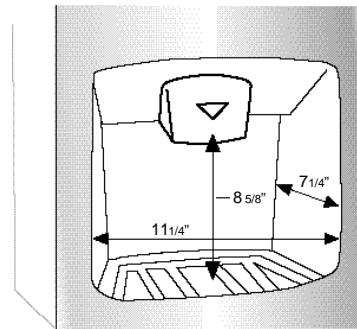
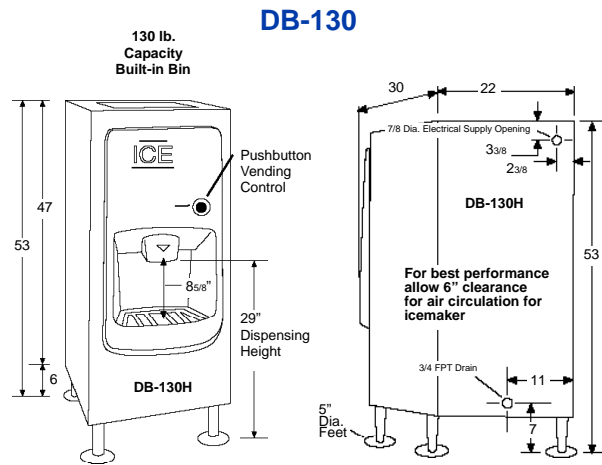

**DB-130 & DB-200 Ice Dispenser Opening**

