

# Indigo™ Series 500 Ice Cube Machine

Model:  IR-0500A  ID-0502A  IY-0504A  IR-0501W  ID-0503W  IY-0505W  
 ID-0592N  IY-0594N



Indigo Series i-500  
Ice Machine on B-570 Bin

Designed for operators who know that ice is critical to their business, the Indigo™ Series ice machine's preventative diagnostics continually monitor itself for reliable ice production. Improvements in cleanability and programmability make your ice machine easy to own and less expensive to operate.

- **Space-Saving Design** – Up to 560 lbs. (254 kgs.) daily ice production and only 30" (76.20 cm) wide.
- **Intelligent Diagnostics** – provide 24 hour preventative maintenance and diagnostic feedback for trouble free operation.
- **Acoustical Ice Sensing Probe** – for reliable operation in challenging water conditions.
- **EasyRead Display** – communicates operating status, cleaning reminders, and asset information through a blue illuminated display.
- **Programmable Ice Production** – by On/Off Time, Ice Volume or Bin Level (with accessory bin level control) further improves energy efficiency and savings.
- **Easy to Clean Foodzone** – Hinged front door swings out for easy access. Removable water-trough, distribution tube, curtain, and sensing probes for fast and efficient cleaning. Select components made with AlphaSan® antimicrobial.
- **DuraTech™ Exterior** – provides superior corrosion resistance. Stainless finish with innovative clear-coat resists fingerprints and dirt.
- Available **LuminIce™ Growth Inhibitor** controls the growth of bacteria and yeast within the foodzone.

## Specifications

**BTU Per Hour:**  
6,100 (average) 6,900 (peak)

**Refrigerant:**  
R-404A CFC-free

- Operating Limits:**
- Ambient Temperature Range:  
35° to 110°F (1.7° to 43.3°C)
  - Water Temperature Range:  
35° to 90°F (1.7° to 32.2°C)
  - Water Pressure Ice Maker  
Water In:  
Min. 20 psi (137.9 kPa)  
Max. 80 psi (551.1 kPa)

## Ice Machine Electric

115/60/1 standard.  
(208-230/60/1 and 230/50/1 available in Air and Water-Cooled models only)

### Minimum circuit ampacity:

Air cooled: 14.2  
Water Cooled: 13.5  
Remote: 20.0

### Maximum fuse size:

Air Cooled: 20.0  
Water Cooled: 20.0  
Remote: 25.0



## Ice Shape

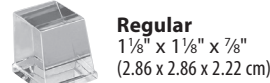
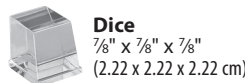
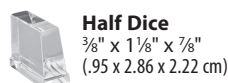

2110 South 26th Street  
PO Box 1720  
Manitowoc, WI 54221-1720 USA

Tel: 1.920.682.0161  
Fax: 1.920.683.7589

www.manitowocice.com





# Indigo™ Series 500 Ice Cube Machine

## i-500 on B-570 Storage Bin

- (A) Electrical Entrance (2) Options
- (B) 3/8" (0.95 cm) F.P.T. Water Condenser Inlet (water-cooled units)
- (C) 1/2" (1.27 cm) F.P.T. Water Condenser Outlet (water-cooled units)
- (D) 1/2" (1.27 cm) Auxiliary Base Drain Socket
- (E) 3/8" (0.95 cm) F.P.T. Ice Making Water Inlet
- (F) 1/2" (1.27 cm) F.P.T. Ice Making Water Drain
- (G) 3/4" (1.91 cm) Bin Drain

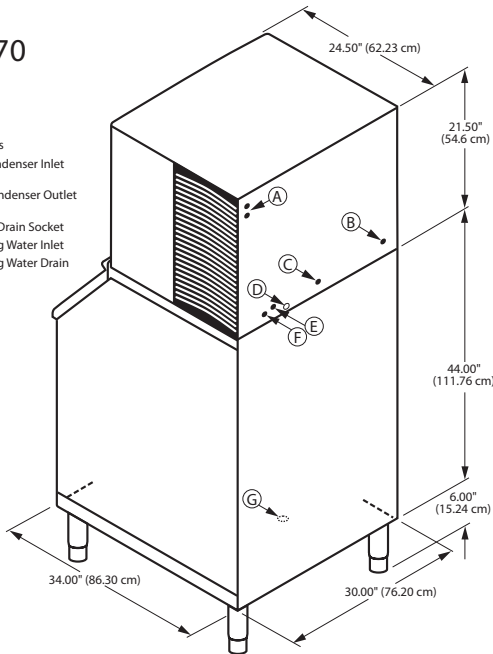

**Installation Note**  
Minimum installation clearance:  
Top/sides: 8" (20.32 cm);  
Back is 5" (12.7 cm)

## Space-Saving Designs



	<b>i-500 B-400</b>	<b>i-500 B-570</b>
Height	59.50" 151.13 cm	71.50" 181.61 cm
Width	30.00" 76.20 cm	30.00" 76.20 cm
Depth	34.00" 86.30 cm	34.00" 86.30 cm
Bin Storage	290 lbs. 131.54 kgs.	430 lbs. 195.04 kgs.

Height includes adjustable bin legs 6.00" to 8.00", (15.24 to 20.32 cm) set at 6.00" (15.24 cm).

## Specifications

Model	Ice Shape	Ice Production 24 Hours		Power Usage kWh/100 lbs. @ 90°Air/70°F	Water Usage/100 lbs. 45.4 kgs. of Ice	ENERGY STAR*
		70°Air/50°F Water	90°Air/70°F Water			
<b>AIR-COOLED</b>	IR-0500A regular	500 lbs.	370 lbs.	5.94	19.9 Gal. 75.3 L	★
		227 kgs.	168 kgs.			
	ID-0502A dice	530 lbs. 240 kgs.	390 lbs. 177 kgs.	5.79	19.9 Gal. 75.3 L	★
IY-0504A half-dice	560 lbs. 254 kgs.	410 lbs. 186 kgs.	5.73	19.9 Gal. 75.3 L	★	
<b>WATER-COOLED</b>	IR-0501W regular	500 lbs.	420 lbs.	4.58	19.9 Gal. 75.3 L	NA
		227 kgs.	191 kgs.			
	ID-0503W dice	550 lbs. 249 kgs.	430 lbs. 195 kgs.	4.58	19.9 Gal. 75.3 L	NA
IY-0505W half-dice	550 lbs. 249 kgs.	440 lbs. 200 kgs.	4.52	19.9 Gal. 75.3 L	NA	
* Water-cooled Condenser Water Usage / 100 lbs. /45.4 kgs. of Ice: 165 gal/625 L * Water-cooled models are excluded from ENERGY STAR qualification.						
<b>REMOTE-COOLED</b>	ID-0592N dice	480 lbs.	430 lbs.	5.79	19.9 Gal. 75.3 L	★
		218 kgs.	195 kgs.			
IY-0594N half-dice	510 lbs. 231 kgs.	440 lbs. 200 kgs.	5.73	19.9 Gal. 75.3 L	★	

Order ice storage bin separately. Ice storage bin and JC-0495 remote condenser must be ordered separately. Consult remote condenser specification sheet for details.

## Accessories

**LuminIce™ Growth Inhibitor**  
reduces yeast and bacteria growth for a cleaner ice machine.



**Bin Level Control**  
Allows ice bin level to be automatically set. Built-in LED light illuminates bin.



**Arctic Pure® Water Filters**  
Reduces sediment and chlorine odors for better tasting ice.



**AuCS®**  
schedules and performs routine ice machine cleaning automatically.



2110 South 26th Street  
PO Box 1720  
Manitowoc, WI 54221-1720 USA

Tel: 1.920.682.0161  
Fax: 1.920.683.7589  
www.manitowocice.com

