

50Hz

iF-300 Ice Cube Machine

iF-300 Ice Cube Machine

Models

IFD-0300A

IYF-0300A



Indigo Series iF-300 Ice Machine on D-400 Bin

Designed for operators who know that ice is critical to their business, the Indigo@NXT Series ice machine's preventative diagnostics continually monitor itself for reliable ice production. Improvements in cleanability and programmability make your ice machine easy to own and less expensive to operate.

- **Space-Saving Design** – Measures only 16.5" high (42 cm) and 30" wide (76.20 cm) allowing it to fit on top of dispensers when a low ceiling is an issue.
- **easyTouch[®] Display**- New icon based touch screen takes the guess work out of owning and operating an ice machine.
- **Multiple Language Capability** - The easyTouch display is available in multiple languages selected in the initial start-up installation Wizard.
- **Programmable Ice Production** – Now its super easy to program your ice machine to be off at certain times of the day to save money with fluctuating electrical rates. Also programmable by daily ice production volume.
- **Easy to Clean Foodzone** – Hinged front door swings out for easy access. Removable water-trough, distribution tube, curtain, and sensing probes for fast and efficient cleaning. Select components made with AlphaSan[®] antimicrobial.
- **Intelligent Diagnostics** – provide 24 hour preventative maintenance and diagnostic feedback for trouble free operation.
- **Acoustical Ice Sensing Probe** – Unique patented technology allows for reliable operation in challenging water conditions and environments.
- **DuraTech[™] Exterior** – provides superior corrosion resistant above stainless steel. Innovative clear-coat resists fingerprints and dirt making it easier to keep clean.
- **Available LuminIce II Growth Inhibitor**- Controls the growth of bacteria and yeast with the food zone keep the machine cleaner longer. A new indicator in the display keeps you abreast of the operational status.

Ice Machine Electric

230/ 50/ 1

Minimum circuit ampacity:

Air-cooled: 6.1

Maximum fuse size:

15 amps 1ph



Specifications

BTU Per Hour:

4,600 (average), 5,450 (peak)

Refrigerant:

R-404A CFC-free

Operating Limits:

- Ambient Temperature Range: 40 to 110 F (4.4 to 43.3 C)
- Water Temperature Range: 40 to 90 F (4.4 to 32.2 C)
- Water Pressure Ice Maker Water In: Min. 20 psi (137.9 kPa) Max. 80 psi (551.1 kPa)

Ice Shape



Half Dice
 $\frac{3}{8}$ " x $1\frac{1}{8}$ " x $\frac{7}{8}$ "
 (.95 x 2.86 x 2.22 cm)
 Cube weight 5.7 g



Dice
 $\frac{7}{8}$ " x $\frac{7}{8}$ " x $\frac{7}{8}$ "
 (2.22 x 2.22 x 2.22 cm)
 Cube weight 8.5 g



COMPANY WITH QUALITY SYSTEM

6646 06/18



50Hz

Indigo[®]NXT iF-300 Ice Cube Machine

iF0300 on a D400 Storage Bin

Installation Note
 Water Cooled clearance:
 Top/Sides: 8" (20.3 cm)
 Back: 5" (12.7 cm)

Air Cooled clearance:
 Top/Sides: 16" (40.6 cm)
 Back: 5" (12.7 cm)

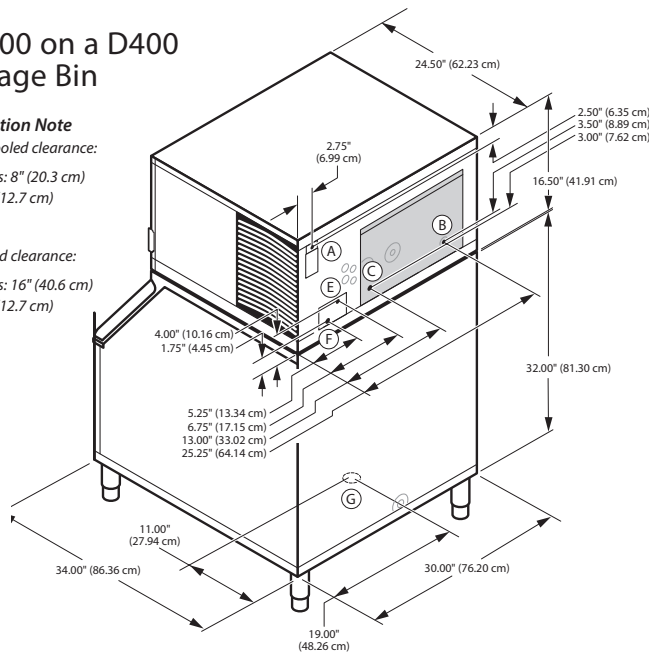

- (A) Electrical Entrance (2) Options
- (B) 3/8" (0.95 cm) F.P.T. Water Condenser Inlet (water-cooled units)
- (C) 1/2" (1.27 cm) F.P.T. Water Condenser Outlet (water-cooled units)
- (D) 1/2" (1.27 cm) Auxiliary Base Drain Socket
- (E) 3/8" (0.95 cm) F.P.T. Ice Making Water Inlet
- (F) 1/2" (1.27 cm) F.P.T. Ice Making Water Drain
- (G) 3/4" (1.91 cm) Bin Drain

Space-Saving Designs



iF0300 D-400

Height	54.50" 138.43 cm
Width	30.00" 76.20 cm
Depth	34.00" 86.30 cm
Bin Storage	365 lbs. 165.7 kgs.

Height includes adjustable bin legs 6.00" to 8.00", (15.24 to 20.32 cm) set at 6.00" (15.24 cm).

Storage bin rated at application capacity based on 90% of the volume x 33 lbs./ft³ average density of ice.

Specifications

Model	Ice Shape	Ice Production 24 Hours		Power Usage kWh 45.4 kg / 100 lbs @ 32°Air / 21°C Water 90°Air / 70°F Water	Water Usage/ 100 lbs. 45.4 kgs. of Ice
		21°Air / 10°C Water 70°Air / 50°F Water	32°Air / 21°C Water 90°Air / 70°F Water		
AIR-COOLED IDF0300A	dice	310 lbs.	235 lbs.	1 Ph	Potable Water
		141 kgs.	107 kgs.		20.0 gal 75.7 L
IYF0300A	half-dice	310 lbs.	235 lbs.	6.95	20.0 gal
		141 kgs.	107 kgs.		75.7 L

Order ice storage bin separately.
 This product is hermetically sealed and contains fluorinated greenhouse gas R404A

Accessories

LuminIce[®] II Growth Inhibitor
 reduces yeast and bacteria growth for a cleaner ice machine.



External Scoop holder

Protect the ice scoop with the NSF approved versatile scoop holder.



Arctic Pure[®] Water Filters

Reduces sediment and chlorine odors for better tasting ice.



Welbilt reserves the right to make changes to the design or specifications without prior notice.

Welbilt Deutschland GmbH
 Auf der Weih 11
 D - 35745 Herbborn, Germany
 Tel.: +49 27 72 58 050
 welbilt.com.de

Welbilt Iberia, S.A.U
 Textil, 6 - Pol.Ind. La Ferreria - 08110
 Montcada i Reixac
 Barcelona, Spain
 Tel.: +34 902 20 10 69
 welbilt.com.es

Welbilt UK
 Ashbourne House The Guildway,
 Old Portsmouth Rd Guildford GU3
 1LR United Kingdom
 Tel.: +44 1483 464900
 www.welbilt.uk

