

iF0900 Ice Cube Machine

iF0900 Ice Cube Machine

Model:

- | | | | |
|------------------------------------|------------------------------------|------------------------------------|------------------------------------|
| <input type="checkbox"/> IRF-0900A | <input type="checkbox"/> IYF-0900A | <input type="checkbox"/> IDF-0900W | <input type="checkbox"/> IDF-0900N |
| <input type="checkbox"/> IDF-0900A | <input type="checkbox"/> IRF-0900W | <input type="checkbox"/> IYF-0900W | <input type="checkbox"/> IYF-0900N |



Indigo NXT Series iF0900 Ice Machine on a D570 Bin

Designed for operators who know that ice is critical to their business, the Indigo[®]NXT Series ice machine's preventative diagnostics continually monitor itself for reliable ice production. Improvements in cleanability and programmability make your ice machine easy to own and less expensive to operate.

- **easyTouch[®] Display**- New icon based touch screen takes the guess work out of owning and operating an ice machine.
- **Programmable Ice Production** - Now its super easy to program your ice machine to be off at certain times of the day to save money with fluctuating electrical rates. Also programmable by daily ice production volume.
- **Easy to Clean Foodzone** - Hinged front door swings out for easy access. Removable water-trough, distribution tube, curtain, and sensing probes for fast and efficient cleaning. Select components made with AlphaSan[®] antimicrobial.
- **Intelligent Diagnostics** - provide 24 hour preventative maintenance and diagnostic feedback for trouble free operation.
- **Acoustical Ice Sensing Probe** - Unique patented technology allows for reliable operation in challenging water conditions and environments.
- **DuraTech[™] Exterior** - provides superior corrosion resistant above stainless steel. Innovative clear-coat resists fingerprints and dirt making it easier to keep clean.
- **Available LuminIce II Growth Inhibitor**- Controls the growth of bacteria and yeast with the food zone keep the machine cleaner longer. A new indicator in the display keeps you abreast of the operational status.

Specifications

BTU Per Hour:

12,700 (average)
14,800 (peak)

Refrigerant:

R-404A CFC-free

Operating Limits:

Ambient Temperature Range:
40 to 100 F (4.4 to 43.3 C)

Water Temperature Range:
40 to 90 F (4.4 to 32.2 C)

Water Pressure Ice Maker Water In:

Min. 20 psi (137.9 kPa)
Max. 80 psi (551.1 kPa)

Ice Machine Electric

208-230/60/1
(208-230/60/3 and 230/50/1 also available)

Minimum circuit ampacity:

Air-cooled:	12.2 1ph	9.7 3ph
Water-cooled:	11.2 1ph	8.7 3ph
Remote:	12.2 1ph	9.7 3ph

Maximum fuse size:

Air-cooled:	20 1ph	15 3ph
Water-cooled:	20 1ph	15 3ph
Remote:	20 1ph	15 3ph



Ice Shape



Half Dice
3/8" x 1 1/8" x 7/8"
(.95 x 2.86 x 2.22 cm)



Dice
7/8" x 7/8" x 7/8"
(2.22 x 2.22 x 2.22 cm)



Regular
1 1/8" x 1 1/8" x 7/8"
(2.86 x 2.86 x 2.22 cm)



COMPANY WITH QUALITY SYSTEM



iF-900 on D-570 Storage Bin

- (A) Electrical Entrance (2) Options
- (B) 3/8" (0.95 cm) F.P.T. Water Condenser Inlet (water-cooled units)
- (C) 1/2" (1.27 cm) F.P.T. Water Condenser Outlet (water-cooled units)
- (D) 1/2" (1.27 cm) Auxillary Base Drain Socket
- (E) 3/8" (0.95 cm) F.P.T. Ice Making Water Inlet
- (F) 1/2" (1.27 cm) F.P.T. Ice Making Water Drain
- (G) 3/4" (1.91 cm) Bin Drain

Installation Note
Minimum installation clearance:

Top/sides: 8" (20.32 cm); Back is 5" (12.7 cm)

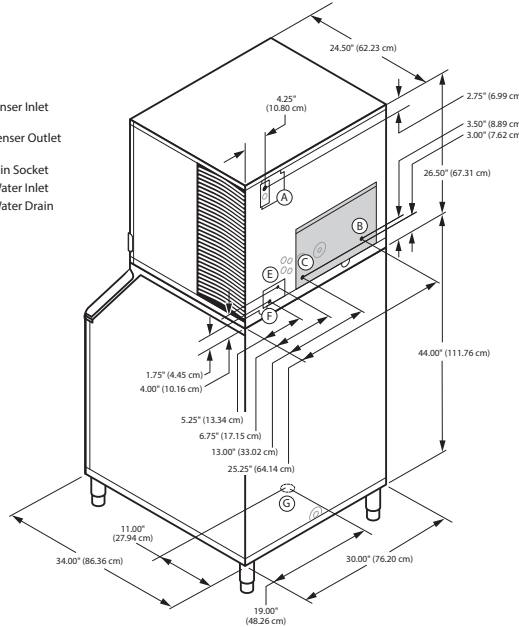

Space-Saving Designs



	iF-900 D-570	iF-900 D-970
Height	76.50" 194.30 cm	76.50" 194.30 cm
Width	30.00" 76.20 cm	30.00" 76.20 cm
Depth	34.00" 86.30 cm	34.00" 86.30 cm
Bin Storage	365 lbs. 165.7 kgs	543 lbs. 241.1 kgs

Height includes adjustable bin legs 6.00" to 8.00", (15.24 to 20.32 cm) set at 6.00" (15.24 cm).
Bin capacity is based on 90% of the volume x 33 lbs/ft³ average density of ice

Specifications

	Model	Ice Shape	Ice Production 24 Hours				Power Usage kWh/100 lbs.@90°Air/70°F		Water Usage/100 lbs. 45.4 kgs. of Ice		ENERGY STAR®
			70°Air/ 50°F Water	90°Air/ 70°F Water	1 Ph	3 Ph	Potable Water				
AIR-COOLED	IRF-0900A	regular	797 lbs	362 kg	639 lbs	290 kg	5.33		19 Gal.	71.9 L	NA
	IDF-0900A	dice	874 lbs	396 kg	664 lbs	301 kg	5.10	5.10	19 Gal.	71.9 L	NA
	IYF-0900A	half-dice	901 lbs	409 kg	710 lbs	322 kg	5.02	5.02	19 Gal.	71.9 L	NA
WATER-COOLED	IRF-0900W	regular	773 lbs	351 kg	683 lbs	310 kg	4.32		19 Gal.	71.9 L	NA
	IDF-0900W	dice	839 lbs	381 kg	701 lbs	318 kg	4.35	4.35	19 Gal.	71.9 L	NA
	IYF-0900W	half-dice	879 lbs	399 kg	786 lbs	357 kg	4.04	4.04	19 Gal.	71.9 L	NA
* Water-cooled Condenser Water Usage / 100 lbs. /45.4 kgs. Of Ice: 145 gal / 549 L. * Water-cooled models are excluded from ENERGY STAR qualification.											
REMOTE-COOLED	IDF-0900N	dice	821 lbs	372 kg	720 lbs	327 kg	4.91	4.91	19 Gal.	71.9 L	★
	IYF-0900N	half-dice	855 lbs	388 kg	745 lbs	338 kg	4.90	4.90	19 Gal.	71.9 L	NA

Order ice storage bin separately. Ice storage bin and JCF900 remote condenser must be ordered separately. Consult remote condenser specification sheet for details.

Accessories

LuminIce® II Growth Inhibitor
reduces yeast and bacteria growth for a cleaner ice machine.



External Scoop holder

Protect the ice scoop with the NSF approved versatile scoop holder.

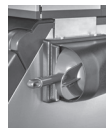

Arctic Pure® Water Filters

Reduces sediment and chlorine odors for better tasting ice.



iAuCS®
schedules and performs routine ice machine cleaning automatically.

