

Elite 40 lb. Fryer

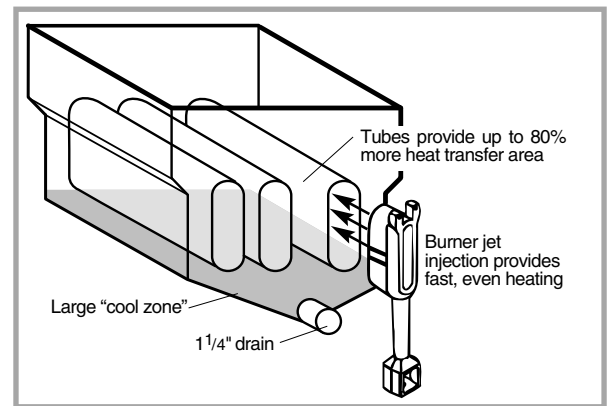

Model# IFS-40



Elite tube-fired heating system - 105,000 BTU

Elite Standard Features

- Stainless steel front, door, sides and stub back.
- Plain or stainless steel frying vessel with 40 lb. oil capacity.
- Large “cool zone” helps capture food particles, prolong oil life and reduce taste transfer.
- Three high efficiency cast iron burners totaling 105,000 BTU/hr.
- Snap acting thermostat has a 200°F - 400°F range.
- 100% safety shut-off.
- Millivolt temperature control circuit.
- Includes two large nickel-plated wire mesh fry baskets with vinyl coated heat resistant handles.
- Rear gas connection.
- 1 1/4" ball valve drains oil quickly.
- Also available in a range match model.
- One year parts and labor warranty.
Limited warranty on fry tank:
Stainless steel tank is 5 yrs. pro-rated
Plain steel tank is 1 yr.
- AGA and CGA design certified and NSF listed.

The Elite 40 lb. Fryer

Imperial provides as standard many of the optional upgrades normally offered at a premium on other fryer lines. The new look features a stainless steel front, door, sides, and basket hanger as standard. To complete this professional look, Imperial welds the stainless steel seams and edges so the Elite Fryer looks as good as it performs.

The Imperial Elite Fryer has more BTU's in its tube-fired heating system than any fryer in its price range. It provides a large heat transfer area that rapidly heats oil to the desired temperature and has a faster recovery than an open pot fryer. The three tube heating system heats the oil quickly resulting in less absorption and a better tasting product. It also reduces scorching for longer oil life. The large “cool zone” captures food particles keeping them from carbonizing in the fry zone. This feature reduces flavor transfer and prolongs oil life.



Elite 40 lb. Fryer

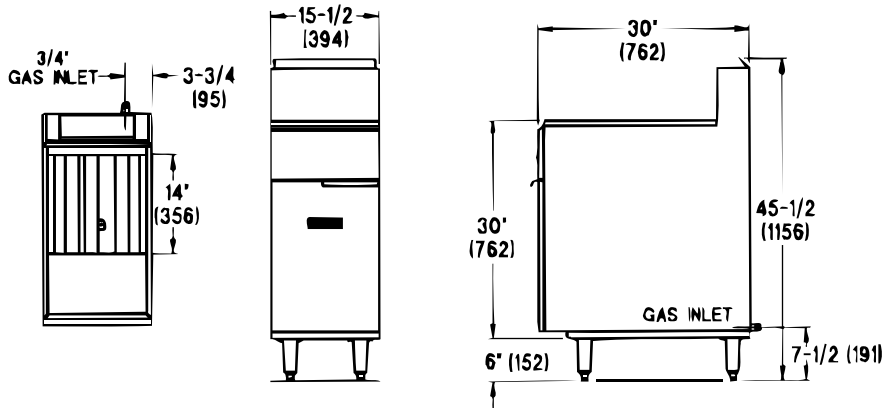

IFP(S)-40

Elite 40 lb. Fryer

Top Configuration	Model#	Description	Tank Style	Oil Capacity	Total B.T.U.	Ship Weight (Kg) (Lbs)	
	IFP-40	Plain Steel Vessel	Plain Steel Vessel	40 lbs.	105,000	100	221
	IFS-40	Stainless Steel Vessel	Stainless Steel Vessel	40 lbs.	105,000	100	221
	IRF-40P Range Match	Plain Steel Vessel	Plain Steel Vessel	40 lbs.	105,000	100	221
	IRF-40SS Range Match	Stainless Steel Vessel	Stainless Steel Vessel	40 lbs.	105,000	100	221

Crated Dimensions: 35" (889mm) H x 36" (891mm) D x 18" (461mm) W

Standard Exterior Finish

- **Stainless Steel:** Front, door, sides, stub back and basket hanger. Welded and finished stainless steel seams.
- **Legs:** Chrome plated with adjustable feet.
- **Dimensions:** 15 1/2" wide x 30" deep x 45 1/2" high.

Fry Tank

- **Vessel:** All welded vessel is made of heavy 14 gauge cold roll steel. Large foam area prevents overflow.
- **Capacity:** 40 lbs. of oil. Produces 72 lbs. of potatoes per hour. Fryer vessel is designed to allow most of the fry basket to be immersed when cooking.
- **Heat Transfer Tubes:** Three fully immersed heat transfer tubes for maximum efficiency. Burners provide 105,000 BTU/hr. Heat retainer baffles inside of tubes are easily removed.
- **Cool Zone:** Large cool zone beneath tubes captures food and breading particles and keeps them out of the frying area to improve food taste and prolong oil life.
- **Basket Hanger:** Stainless steel hanger is easily removed for cleaning.
- **Crumb Screen:** Removable fine mesh crumb screen.
- **Drain Pipe and Clean Out Rod:** Includes removable drain pipe and clean out rod.

Optional Items

Stainless steel frying vessel; portable oil filter unit; fryer drain station with a storage cabinet; quick disconnect hose and restraining device; stainless steel strip to cover between fryers; various size fry baskets; swivel casters (front two casters are locking); stainless steel backguard.

Restaurant range match fryers are available.

Fryer Filter Systems: Pre-packaged systems with matching cabinet and built-in filter and pan, stainless steel dump station and food warmer are available. System options include solid state thermostat control, computer fry control and basket lifts.

Gas

Manifold pressure is 4.0" W.C. for natural gas or 11.0" for propane gas. Manifold size 3/4" NPT. 3/4" pressure regulator supplied with equipment to be installed at time of connection. Specify type of gas and elevation if over 2,000 ft.

Clearance

For use only on non-combustible floors. Legs or casters are required for non-combustible floors; or 2" overhang is required when curb mounted. Provide 0" clearance from non-combustible surfaces and 6" from combustible surfaces.



Commercial Cooking Equipment

1560 Flower Street, Duarte, CA 91010 Phone (626) 357-7411 FAX (626) 359-5909
 Web Site: www.imperialrange.com E-mail: impsls@imperialrange.com