

REFRIGERATOR MANUFACTURER
Turbo air
 more durable, efficient, beautiful

4184 E. Conant St.
 Long Beach, CA 90808
 Tel. 310-900-1000
 Fax. 310-900-1077
www.turboairinc.com

Project :	
Model # :	
Item # :	Qty :
Available W/H :	
Approval :	

Buffet Display Table

Food Prep Tables
 J Series

Model : JBT-60-N



* Sneeze guard sold separately

FEATURES & BENEFITS

- Digital temperature control & monitor system**
 Keep food products safe by maintaining constant temperatures. External digital display allows for easy monitoring.
- Hydrocarbon refrigerants (R-290)**
 With innovative and eco-friendly technology, Turbo Air brings you hydrocarbon refrigerators designed to meet DOE's Energy Conservation Standards in 2017 and to use EPA's SNAP Program approved HC refrigerants. Hydrocarbon refrigerants do not deplete the ozone layer and have very low contribution to global warming (ODP-0, GWP-3).
- Exterior & interior of the cabinet**
 The Turbo Air J series boasts all stainless steel exterior including back (galvanized steel bottom). Interior is stainless steel floor with AL sides, back and AL door liners. It guarantees the utmost in cleanliness and long product life. The J series adds a touch of style to the most refined setting.
- Side mount compressor unit**
 With compressors positioned on the side of the unit, our refrigerators can now be serviced without being moved. Our innovative, front breathing feature also allows this model to be highly efficient in narrow spaces.
- Hot gas condensate system**
 Through Turbo Air's creative innovation, the condensate system surfaces have been specially treated to resist corrosion. This not only increases efficiency without the risk of refrigerant leakage from corrosion, but also thoroughly prevents the overflow of condensate water.
- Adjustable, heavy duty, PE (polyethylene) coated wire shelves**
- High-density polyurethane insulation**
 The entire cabinet structure and solid doors are foamed-in-place using high density, CFC free polyurethane insulation.
- Ergonomically designed doors**
 Customers' fatigue fades away with easy grip handles and doors that open effortlessly. These features along with self-closing doors make this the ultimate choice in customer convenience.
- Magnetic door gaskets**
 Magnetic door gaskets are of one-piece construction, removable without tools for ease of cleaning and replacement.
- Easy open front grille with condenser cleaning brush kit**
 Front grille cover is easily removable without any tools, which makes condenser cleaning easy and convenient at any time. Handy condenser cleaning brush is included inside the front grille cover.
- Double sided polycarbonate sneeze guard (optional)**
 The transparent polycarbonate cover is durable, and the two 304 stainless steel side stands are easy to clean and anticorrosive.
- Refrigerator holds 33°F ~ 39°F for the best in food preservation**



Model	Swing Door	CU./FT.	#of Shelves	#of Pans (1/3)	HP	AMPS	Crated Weight (lbs.)	L x D x H* (inches)
JBT-60-N	2	15	2	12	1/2	5.46	235	59 x 27 1/2 x 28 3/4

Model : JBT-60-N

ELECTRICAL DATA	
Voltage	115/60/1
Plug Type	① NEMA 5-15P
Full Load Amperes	5.46
Compressor HP	1/2
Cord Length (ft.)	9.2
Refrigerant	R-290
DIMENSIONAL DATA	
Ext. Length Overall (in.)	59 (1499mm)
Ext. Depth Overall (in.)	27 1/2 (698mm)
Ext. Height Overall (in.)*	28 3/4 (730mm)
# of Doors	2
# of Shelves	2
# of Pans	12
Net Capacity (cu. ft.)	15
Net Weight (lbs.)	200
Gross Weight (lbs.)	235
Shelf Size (in.)	21 1/2 x 17 3/4

Design and specifications subject to change without notice.

Actual shipping weight may differ due to extra packing materials for product protection.

* Height does not include 5" for caster with stem height.

■ **WARRANTY : 2 Year Parts and Labor Warranty
Additional 3 Year Warranty on Compressor**

■ **STANDARD FEATURES**

- Anti-corrosion coated evaporator
- Self-contained system
- Standard 4" dia. swivel casters with locks on the front set
- 1/3 size condiment pans included

■ **OPTIONAL ACCESSORIES :**

- 2.5" caster, 1/2" diameter & 13 TPI: 30265H0100 (non-brake), 30265H0200 (w/ brake)
- 5" caster, 1/2" diameter & 13 TPI: M726500100 (non-brake), M726500200 (w/ brake)
- 6" ABS plastic leg: 30221M0200
- 6" stainless steel leg: 30221M0600
- Additional PE coated wire shelf: BR59000102
- Sneeze guard: SNZ-60
- Tray slide: TS-60
- Clear pan cover: PC-60J
- Door lock: extra lead time will apply, please call factory for more details to order

PLAN VIEW

(unit : inch)

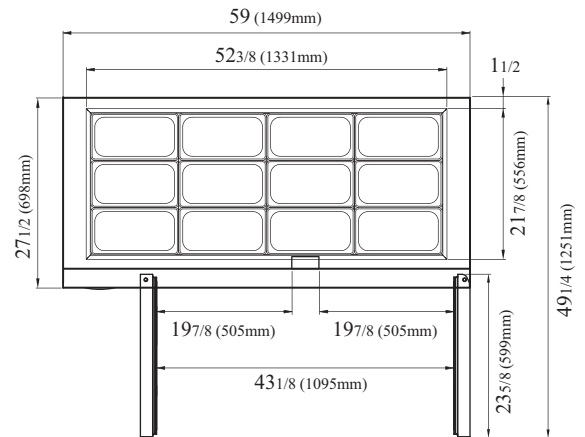

PLAN VIEW

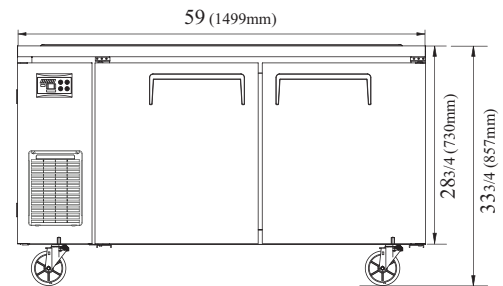

FRONT VIEW

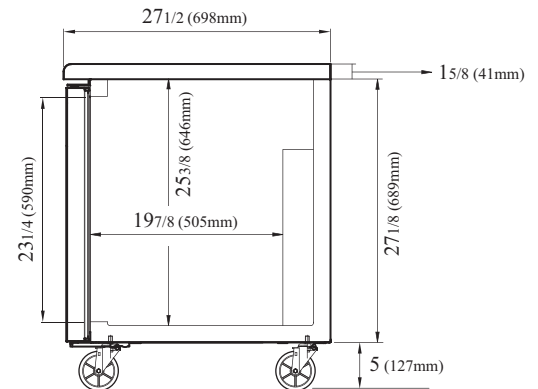

SIDE VIEW

Ver.20181211



- Turbo Air : 800-627-0032
- GK : 800-500-3519
- Warranty : 800-381-7770
- AC : 888-900-1002

