

REFRIGERATOR MANUFACTURER
Turbo air
 more durable, efficient, beautiful

4184 E. Conant St.
 Long Beach, CA 90808
 Tel. 310-900-1000
 Fax. 310-900-1077
www.turboairinc.com

Project :	
Model # :	
Item # :	Qty :
Available W/H :	
Approval :	

Solid Door Freezer

Reach-In Top Mount
 J Series

Model : JF25-1

≡ FEATURES & BENEFITS ≡

- **Digital temperature control system**
 Provides precise and constant temperature. This level of precision allows food products to remain fresh over an extended period of time.
- **High-tech monitor**
 The monitor digitally displays present cabinet temperatures. You can easily change the temperature by adjusting the thermostat.
- **Hot gas condensate system**
 Through Turbo Air's creative innovation, the condensate system surfaces have been specially treated to resist corrosion. This not only increases efficiency without the risk of refrigerant leakage from corrosion, but also prevents the overflow of condensate water.
- **Door pressure release device**
 Pressure relief doors are designed to eliminates vacuum pressure and allows easy, instant door opening.
- **LED interior lighting system**
 Brighter and longer lasting LED lights provide attractive, enhanced illumination compared to fluorescents. It saves energy by producing less heat, while maximizing the visibility.
- **Turbo Freeze feature for faster freezing**
 When in Turbo Freeze mode, the built-in program allows the compressor to run continuously for two hours. This helps the temperature to decrease more quickly inside the cabinet, which results in reaching freezing temperatures much faster.
- **Field reversible hinge**
- **Efficient refrigeration system**
 Turbo Air's J series solid door freezers are designed with oversized and balanced (CFC Free R-404A) refrigeration systems. These include efficient evaporators and condensers for faster freezing and greater efficiency.
- **Automatic evaporator fan motor delays**
 When the door is opened the evaporator fan will stop, preventing the circulation of hot and moist air from escaping into the refrigerator. This increases energy efficiency and lengthens the life of the compressor.
- **Adjustable, heavy duty, PE(polyethylene) coated wire shelves**
- **Exterior & interior of cabinet construction**
 Stainless steel exterior (galvanized steel top, bottom and back) and stainless steel interior with AL inside walls and door liners. It guarantees the utmost in cleanliness and long product life. Unlike other companies' products, the sharp corners and edges have been rounded to reduce the risk of injury.
- **High-density polyurethane insulation**
 The entire cabinet structure and solid doors are foamed-in-place using high density, CFC free polyurethane insulation.



Freezer holds -10°F ~ 0°F for the best in frozen food preservation



Model	Swing Door	CU./FT.	#of Shelves	HP	AMPS	Crated Weight (lbs.)	L x D* x H † (inches)
JF25-1	1	20.27	3	1/2	7.5	190	25 1/8 x 31 1/2 x 72

Model : JF25-1

ELECTRICAL DATA	
Voltage	115/60/1
Plug Type	Ⓜ NEMA 5-15P
Full Load Amperes	7.5
Compressor HP	1/2
Feed Wires with Ground	3
Cord Length ft.	9
Refrigerant	R-404A
DIMENSIONAL DATA	
# of Doors	1
Net Capacity cu. ft.	20.27
Ext. Length Overall in.	25 1/8 (640mm)
Ext. Depth Overall in.*	31 1/2 (800mm)
Ext. Height Overall in.†	72 (1829mm)
Int. Length Overall in.	21 5/8 (551mm)
Int. Depth Overall in.	27 3/8 (695mm)
Int. Height Overall in.	52 1/2 (1333mm)
Gross Weight lbs.	176
Net Weight lbs.	190
# of Shelves	3
Self Size	20 5/8 x 23 7/8

Design and specifications subject to change without notice.
Actual shipping weight may differ due to extra packing materials for product protection.
* Depth does not include 2" for rear condensate enclosure.
† Height does not include 5" for caster height.

■ **WARRANTY : 2 Year Parts and Labor Warranty
Additional 3 Year Warranty on Compressor**

- **Door locks standard**
- **Self-contained system**
- **Standard 4" swivel casters with locks on the front set**
- **Solid and sturdy grille design**
- **Legs available for all models (optional)**

■ **OPTIONAL ACCESSORIES :**

- 2.5" Diameter casters
- 5" Diameter casters
- 6" ABS plastic legs
- Additional PE coated wire shelves

PLAN VIEW

(unit : inch)

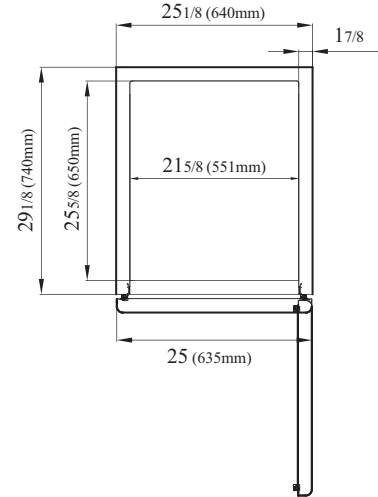

TOP VIEW

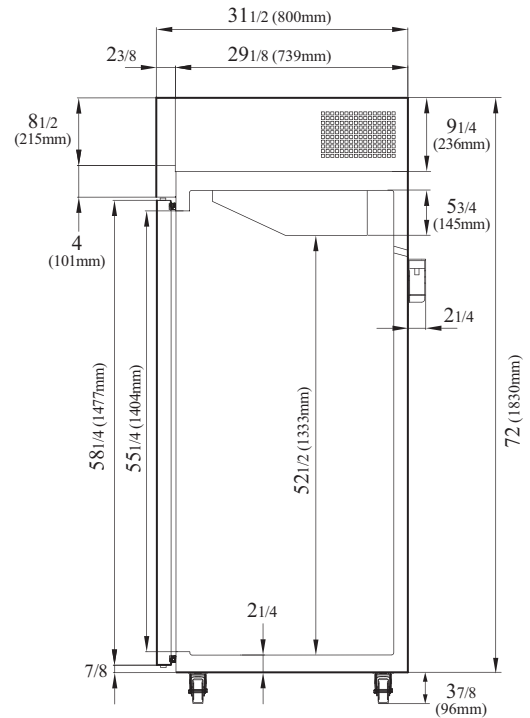

SIDE VIEW

Ver.201501



- Turbo Air : 800-627-0032
- GK : 800-500-3519
- Warranty : 800-381-7770
- AC : 888-900-1002