

"C2H" CONDENSATE HOOD

18GA Stainless Steel

FEATURES:

- 18GA Stainless Steel Construction
- Full Perimeter Gutter
- Welded Hanging Baskets

CERTIFICATIONS:



C2H-36-2

"C2H" CONDENSATE HOOD

MODEL	SIZE (L X W X H)	CFM	WEIGHT (LBS)
C2H-36-2	36"x36"x19"	450	120
C2H-42-2	42"x42"x19"	600	210
C2H-60-2	60"x42"x19"	875	300

ALL DIMENSIONS ARE TYPICAL. TOLERANCE +/- .500". JOHN BOOS & CO. RESERVES THE RIGHT TO CHANGE SPECIFICATIONS WITHOUT NOTICE.

DETAILED SPECIFICATIONS

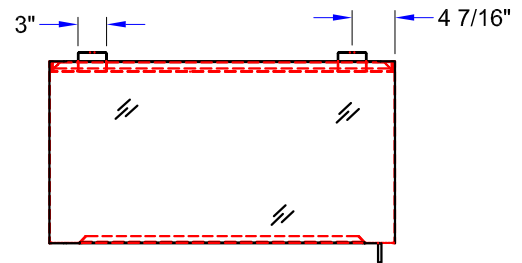
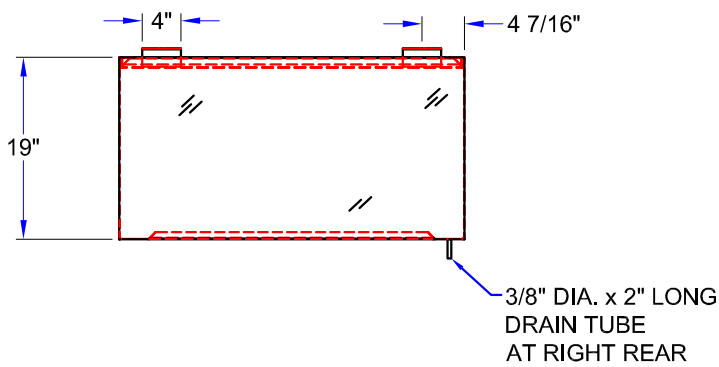
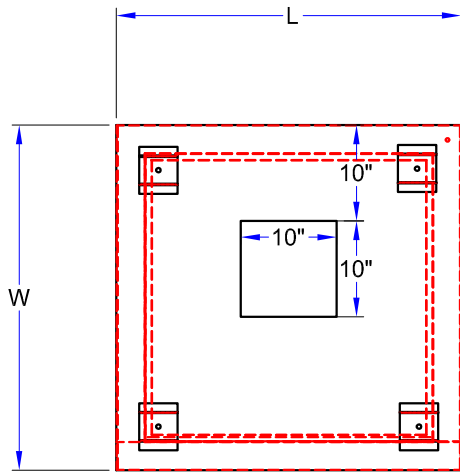

"C2H" CONDENSATE HOOD

MODEL	SIZE (L X W X H)	CFM	WEIGHT (LBS)
C2H-36-2	36"x36"x19"	450	120
C2H-42-2	42"x42"x19"	600	210
C2H-60-2	60"x42"x19"	875	300

ALL DIMENSIONS ARE TYPICAL. TOLERANCE +/- .500". JOHN BOOS & CO. RESERVES THE RIGHT TO CHANGE SPECIFICATIONS WITHOUT NOTICE.