

"TYC" TEPPANYAKI CART

16GA S.S. Top

FEATURES:

- 16GA Stainless Steel Top
- Type 300 Stainless Steel With #4 Polish, Satin Finish
- 18/300 Stainless Steel Midshelf
- 14 Half Size Steam Table Pan Capacity
- 3-3/8" Pan Rack Centers
- 5" Clocking Casters
- Welded Set-Up



"TYC" TEPPANYAKI CART

MODEL	SIZE (LXWXH)	WT (LBS)
TYC-1530	33-5/8"x14-1/2"x33-3/4"	68

ALL DIMENSIONS ARE TYPICAL. TOLERANCE +/- .500". JOHN BOOS & CO. RESERVES THE RIGHT TO CHANGE SPECIFICATIONS WITHOUT NOTICE.

DETAILED SPECIFICATIONS

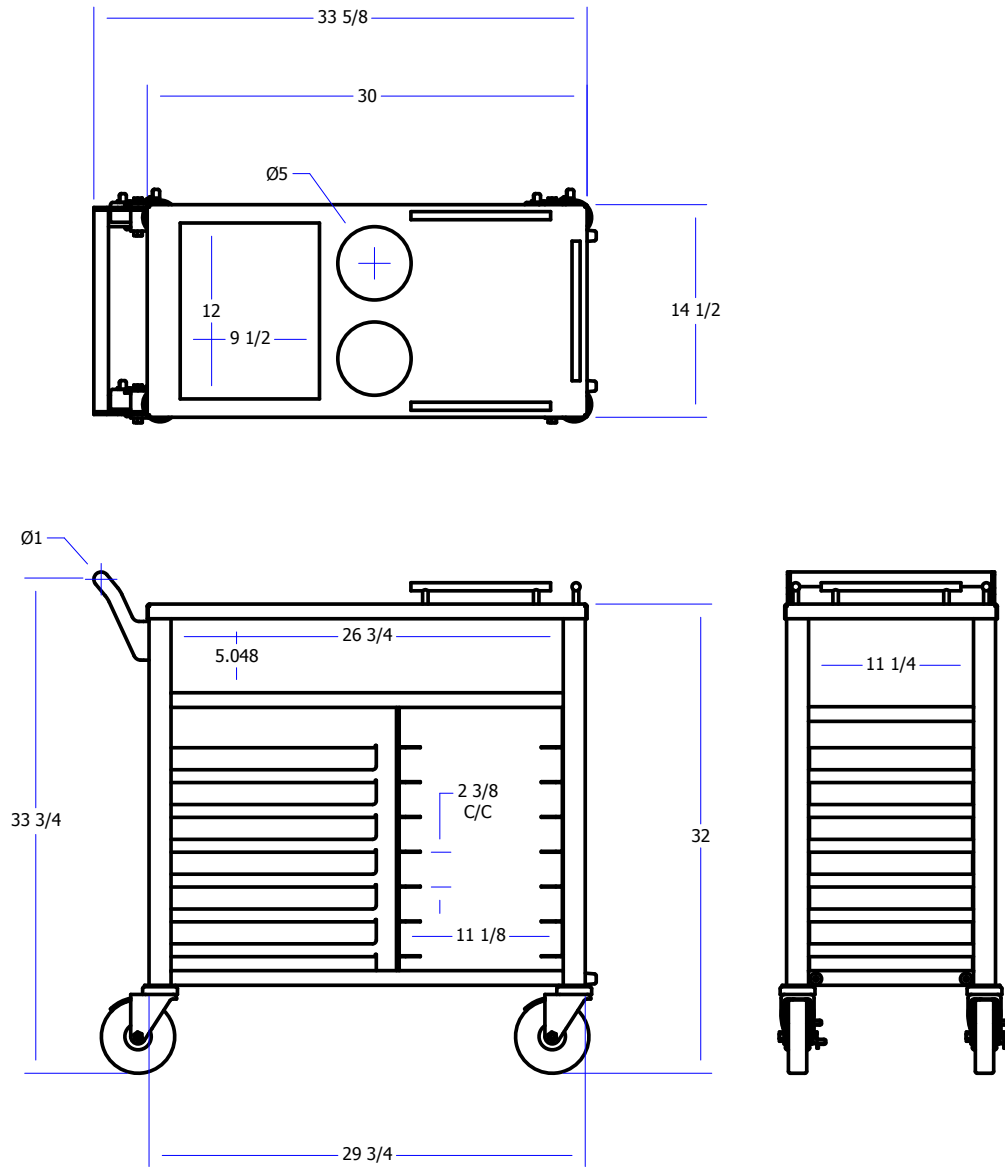

"TYC" TEPPANYAKI CART

MODEL	SIZE (LXWXH)	WT (LBS)
TYC-1530	33-5/8"x14-1/2"x33-3/4"	68

ALL DIMENSIONS ARE TYPICAL. TOLERANCE +/- .500". JOHN BOOS & CO. RESERVES THE RIGHT TO CHANGE SPECIFICATIONS WITHOUT NOTICE.