

KM-201B_H

SELF-CONTAINED CUBER WITH BUILT-IN STORAGE BIN

Item # _____

Project: _____

Qty: _____

*AutoCad available on KCL

KM-201B_H

2/11

Item # 13238

CUBER DIMENSIONS

W x D x H

KM-201B_H

24 x 28 x 39*

*with 6" legs





KM-201BAH

Air-Cooled
Shown

KM-201BWH

Water-Cooled

- Up to 215 lbs. of ice production per 24 hours
- Built-in 80 lbs. ice storage
- Individual crescent cube
- Durable stainless steel exterior
- CycleSaver® Design 
- EverCheck® alert system 
- Stainless steel evaporator
- Removable air filter (Air-cooled model only)
- Complies with California Energy Commission guidelines (CEC)
- R-404A Refrigerant

* The KM-201BAH is ENERGY STAR qualified.

Warranty

Valid in United States, Canada, Puerto Rico, & U.S. Territories. Contact factory for warranty in other countries.

Three Year - Parts & Labor on entire machine.

Five Year - Parts & Labor on: Evaporator.

Five Year - Parts on: Compressor, air-cooled condenser coil.



© HOSHIZAKI AMERICA, INC.

618 Hwy. 74 S., Peachtree City, GA 30269

TEL 1-800-438-6087

FAX 1-800-345-1325

www.hoshizaki.com



A City Discount

SELF-CONTAINED CUBER WITH BUILT-IN STORAGE BIN

DIMENSIONS
W x D x H
KM-201B_H
24 x 28 x 39"
*with 6" legs

- Air-cooled
- Water-cooled

AIR-COOLED

Water Temp ° F.	50°	70°	90°
Air Temp ° F.			
70°	201	190	176
80°	193	177	162
90°	190	165	150

WATER-COOLED

Water Temp ° F.	50°	70°	90°
Air Temp ° F.			
70°	215	205	192
80°	207	192	180
90°	205	181	168

UTILITY CONSUMPTION

Model Number	Ice Production Per Cycle		KWH per 100 LBS. 90/70	Potable Water Gal. per 100 lbs.	Condenser Water Gal. per 100 lbs.
	Lbs.	Cubes			
KM-201BAH	4	182	7.5	22.0	N/A
KM-201BWH	4	182	6.17	24.0	141.3

SPECIFICATIONS

Model Number	Condenser	Amperage	Shipping Weight
KM-201BAH	Air-Cooled	6.1	165 lbs.
KM-201BWH	Water-Cooled	5.5	165 lbs.

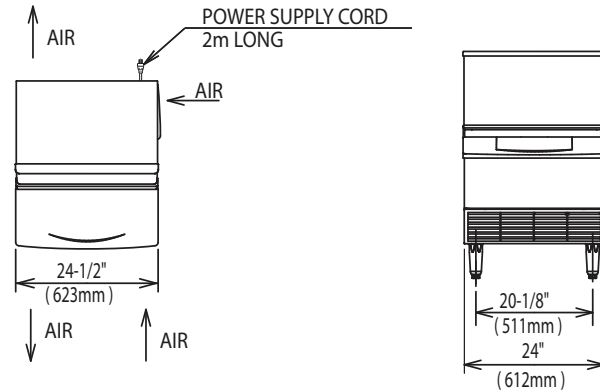

TOP VIEW - AIR-COOLED UNIT

FRONT VIEW

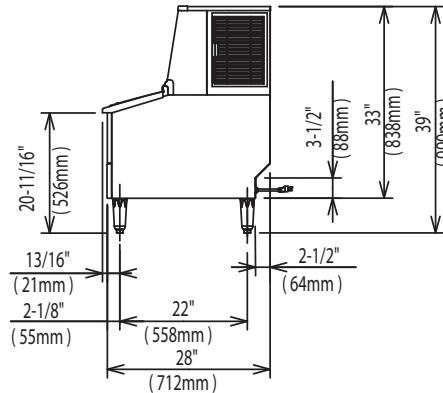

SIDE VIEW
(LOUVERS ON AIR-COOLED UNIT ONLY)

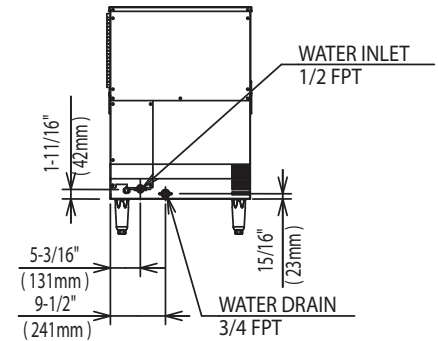

BACK VIEW - AIR-COOLED UNIT

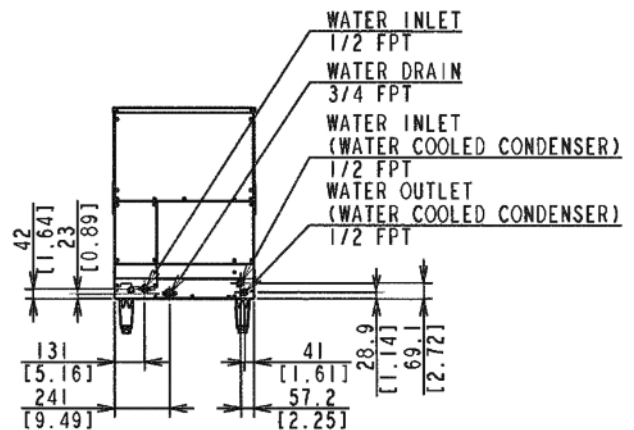

BACK VIEW / AIR-COOLED UNIT

ELECTRICAL & PLUMBING/KM-201BWH

- 115V/60/1
- 15 amp Max Fuse/HACR Breaker Size
- 3/8" OD copper or equivalent independent potable water supply
- 3/4" FPT independent drain connection
- 1/2" FPT water inlet



© HOSHIZAKI AMERICA, INC.

OPERATING LIMITS

- Ambient Temp Range 45 - 100°F
- Water Temp Range 45 - 90°F
- Water Pressure 10 - 113psig
- Voltage Range 104 - 127V

SERVICE

- Panels easily removed and all components accessible for service.
- Removable/cleanable air filters (Air-cooled model only)

