

# KM-260B\_H

## SELF-CONTAINED CUBER WITH BUILT-IN STORAGE BIN

Item # \_\_\_\_\_

Project: \_\_\_\_\_

Qty: \_\_\_\_\_

\*AutoCad available on KCL

KM-260B\_H

9/12

Item # 13239

### CUBER DIMENSIONS W x D x H

**KM-260B\_H**  
30 x 28 x 39\*  
\*with 6" legs





### KM-260BAH

Air-Cooled  
Shown

### KM-260BWH

Water-Cooled

- Up to 268 lbs. of ice production per 24 hours
- Built-in 100 lbs. ice storage
- Individual crescent cube
- Durable stainless steel exterior
- Ice bin opening is ADA compliant
- CycleSaver® Design 
- EverCheck® alert system 
- Stainless steel evaporator
- Removable air filter (Air-cooled model only)
- R-404A Refrigerant

\* The KM-260BAH is ENERGY STAR qualified.

### Warranty

Valid in United States, Canada, Puerto Rico, & U.S. Territories. Contact factory for warranty in other countries.

**Three Year** - Parts & Labor on entire machine.

**Five Year** - Parts & Labor on: Evaporator.

**Five Year** - Parts on: Compressor, air-cooled condenser coil.



© HOSHIZAKI AMERICA, INC.

618 Hwy. 74 S., Peachtree City, GA 30269

TEL 1-800-438-6087

FAX 1-800-345-1325

www.hoshizaki.com



A City Discount

# Hoshizaki

## SELF-CONTAINED CUBER WITH BUILT-IN STORAGE BIN

KM-260B\_H

**DIMENSIONS**  
W x D x H  
**KM-260B\_H**  
30 x 28 x 39"  
\*with 6" legs

- Air-cooled
- Water-cooled

### AIR-COOLED

Water Temp ° F.	50°	70°	90°
Air Temp ° F. 70°	263	245	227
Air Temp ° F. 80°	249	220	207
Air Temp ° F. 90°	245	200	185

### WATER-COOLED

Water Temp ° F.	50°	70°	90°
Air Temp ° F. 70°	268	259	242
Air Temp ° F. 80°	261	247	228
Air Temp ° F. 90°	259	237	218

### UTILITY CONSUMPTION

Model Number	Ice Production Per Cycle		KWH per 100 LBS. 90/70	Potable Water Gal. per 100 lbs.	Condenser Water Gal. per 100 lbs.
	Lbs.	Cubes			
KM-260BAH	5	238	7.6	20.3	N/A
KM-260BWH	5	238	6.4	26.3	121

### SPECIFICATIONS

Model Number	Condenser	Amperage	Shipping Weight
KM-260BAH	Air-Cooled	7.6	187 lbs.
KM-260BWH	Water-Cooled	7.5	187 lbs.

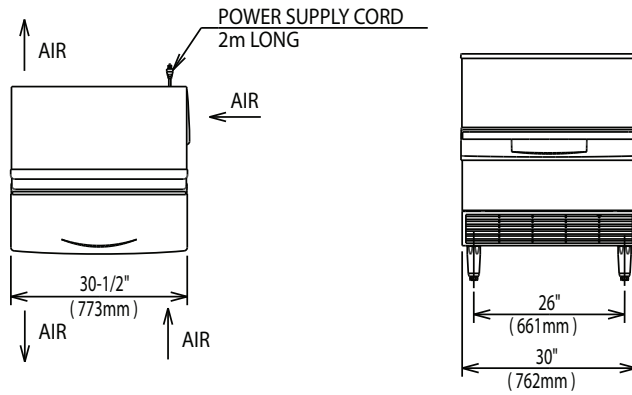

TOP VIEW

FRONT VIEW

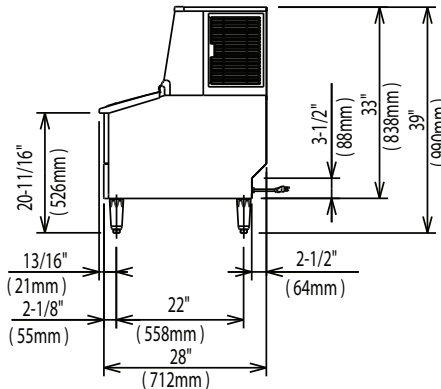

SIDE VIEW

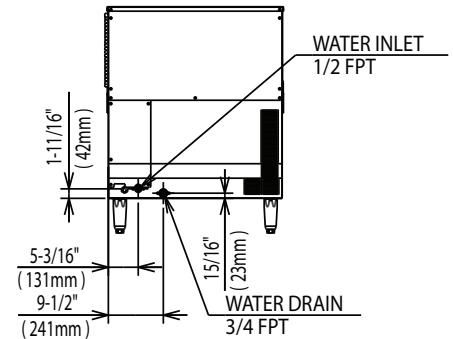

BACK VIEW / AIR-COOLED UNIT

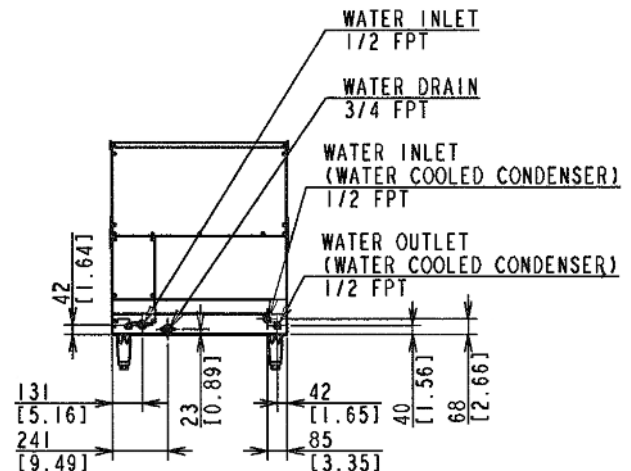

BACK VIEW / AIR-COOLED UNIT

### ELECTRICAL & PLUMBING/KM-260B\_H

- 115V/60/1
- 15 amp Max Fuse/HACR Breaker Size
- 3/8" OD copper or equivalent independent potable water supply
- 3/4" FPT independent drain connection
- 1/2" FPT water inlet



© HOSHIZAKI AMERICA, INC.

618 Hwy. 74 S., Peachtree City, GA 30269

### OPERATING LIMITS

- Ambient Temp Range 45 - 100°F
- Water Temp Range 45 - 90°F
- Water Pressure 10 - 113psig
- Voltage Range 104 - 127V

### SERVICE

- Panels easily removed and all components accessible for service.
- Removable/cleanable air filters (Air-cooled model only)

TEL 1-800-428-6087

FAX 1-800-345-1325

www.hoshizaki.com

Printed in U.S.A.

A City Discount

