

KM-901M_H50

MODULAR CRESCENT CUBER

Item # _____

Project: _____

Qty: _____

*AutoCad available on KCL

KM-901M_H50

6/11

Item # 13268

CUBER DIMENSIONS

W x D x H

KM-901M_H50
30 x 27^{3/8} x 37^{7/16}

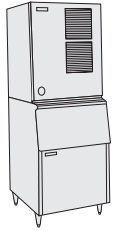

B-500

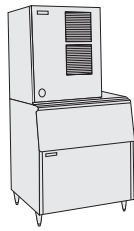

B-700

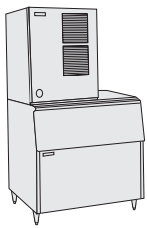

B-800

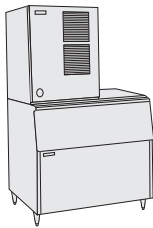

B-900



KM-901MAH50

Air-Cooled
Shown on an optional
B-900

KM-901MRH50

Remote Air-Cooled | Phase

Also available on Large Bins:

B-1150SS
B-1300SS
B-1500SS
B-1650SS

- Up to 402 kg of ice production per 24 hours
- Durable stainless steel exterior
- Individual crescent cube
- Protected by *H-GUARD Plus* Antimicrobial Agent
- CycleSaver® Design
- EverCheck® alert system
- Stainless steel evaporator
- Removable air filters (Air-cooled model only)
- R-404A Refrigerant



Warranty

Contact factory for warranty information.



Hoshizaki

KM-90IM_H50 MODULAR CRESCENT CUBER

DIMENSIONS
W x D x H
KM-90IM_H50
30 x 27^{3/8} x 37^{7/16}

- Air-cooled
- Remote Air-cooled

AIR-COOLED

Water Temp° C.	10°	21°	32°
Air Temp° C.			
21°	398	375	349
27°	381	345	322
32°	375	320	295

REMOTE AIR-COOLED

Water Temp° C.	10°	21°	32°
Air Temp° C.			
21°	402	385	358
27°	389	363	334
32°	385	345	316

UTILITY CONSUMPTION at 32°C A/ 21°C W

Model Number	Ice Production Per Cycle		KWH per 45 Kg	Potable Water Liters per 45 kg	Condenser Water Liters per 45 kg
	Kg	Cubes			
KM-901MAH50	6.2	720	5.1	60	N/A
KM-901MRH50	6.2	720	5.0	60	N/A

SPECIFICATIONS

Model Number	Condenser	Amperage	Min. Circuit Ampacity	Shipping Weight
KM-901MAH50	Air-Cooled	9.0	20	116 kg
KM-901MRH50	Remote Air-Cooled	9.2	20	113 kg

STORAGE BINS

Model Number	Application Capacity
B-500	227 kg
B-700	318 kg
B-800	363 kg
B-900	409 kg
B-1150	522 kg
B-1300	578 kg
B-1500	676 kg
B-1650	728 kg

ELECTRICAL & PLUMBING/KM-90IM_H50

- 220-240/50/1
- 20 amp Max Fuse/HACR Breaker Size
- 0.95cm copper or equivalent independent potable water supply
- 3/4" FPT independent drain connection



ISO 9001:2015

© HOSHIZAKI AMERICA, INC.

618 Hwy. 74 S., Peachtree City, GA 30269



FRONT VIEW (Air-Cooled)

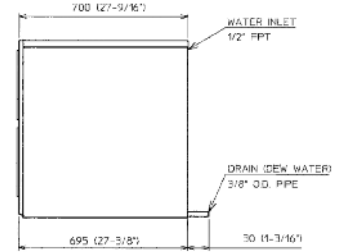

SIDE VIEW (Air-cooled)

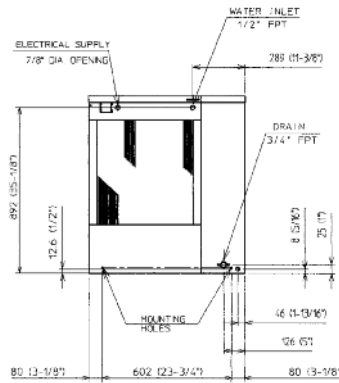

AIR-COOLED UNIT

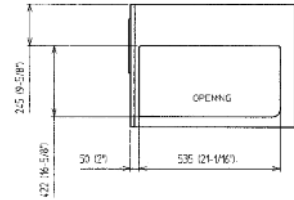

ICE DROP ZONE

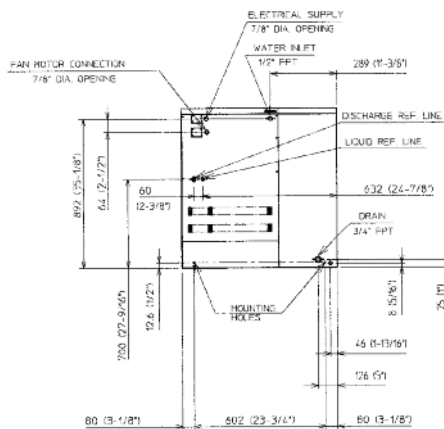

REMOTE AIR-COOLED UNIT

URC-9F Remote Condenser (Sold Separately)
For Use with KM-901MRH50

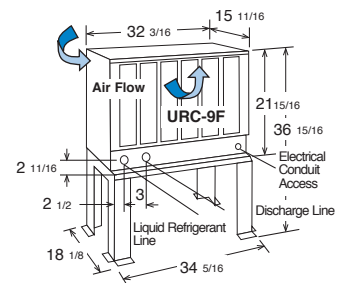

Pre-Charged Tubing Kits

- (Sold Separately)
- 20' R404-2068-2
- 35' R404-3568-2
- 55' R404-5568-2



Voltage supply for the URC Remote Condenser is supplied from the Ice Maker. No additional circuit is required.

OPERATING LIMITS

- Ambient Temp Range 7 - 38°C
- Water Temp Range 7 - 32°C
- Water Pressure 0.7 - 8 kg/cm²
- Voltage Range 198 - 254V

CONDENSING UNIT

- Voltage Range 104 - 127V
- Ambient Temp Range -29 - 50°C

SERVICE

- Panels easily removed and all components accessible for service.
- Removable/cleanable air filters (Air-Cooled model only)

TEL 1-800-438-6087

FAX 1-800-345-1325

www.hoshizaki.com

Printed in U.S.A.

A City Discount

