

KMD-460M_H

MODULAR CRESCENT CUBER

Item # _____

Project: _____

Qty: _____

* AutoCad available on KCL

KMD-460M_H

11/20/15

Item# 13346

CUBER DIMENSIONS

W x D x H

KMD-460M_H
30 x 24^{1/4} x 22^{1/8}



KMD-460MAH

Air-Cooled

Shown on an optional
Lancer 30" Dispenser

KMD-460MWH

Water-Cooled

Available on Bins:

B-250PF
B-500PF/SF
BD-500PF/SF
B-700PF/SF
B-800PF/SF
B-900PF/SF

Large Bins:

B-1150SS
B-1300SS

- Up to 505 lbs. of ice production per 24 hours
- Ice on beverage design
- Durable stainless steel exterior
- Individual crescent cube
- Protected by H-GUARD Plus Antimicrobial Agent **HOSHIGUARD**
- CycleSaver™ Design **CYCLESAVER**
- EverCheck™ alert system **evercheck**
- Stainless steel evaporator
- Removable air filters (Air-cooled model only)
- Front air inlet panels available for side-by-side application (used with HS-5065 Kit)
- R-404A Refrigerant

* The KMD-460MAH is ENERGY STAR qualified.

*KM CUBE DIMENSIONS

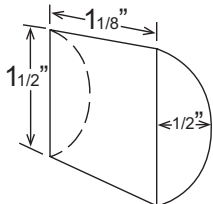

*approximate size in inches, image not to scale

Warranty

Valid in United States, Canada, Puerto Rico, & U.S. Territories. Contact factory for warranty in other countries.

- Three Year - Parts & Labor on entire machine.
- Five Year - Parts & Labor on Evaporator.
- Five Year - Parts on; Compressor, air-cooled condenser coil.



© HOSHIZAKI AMERICA, INC.

618 Hwy, 74 S., Peachtree City, GA 30269

TEL 1-800-438-6087

FAX 1-800-345-1325

www.hoshizaki.com



HOSHIZAKI

DIMENSIONS
W x D x H
KMD-460M_H
30 x 24^{1/4} x 22^{1/8}

- Air-cooled
- Water-cooled

KMD-460M_H MODULAR CRESCENT CUBER

AIR-COOLED

Water Temp° F.	50°	70°	90°
Air Temp° F.	70°	457	436
	80°	441	409
	90°	436	387

WATER-COOLED

Water Temp° F.	50°	70°	90°
Air Temp° F.	70°	505	495
	80°	497	481
	90°	495	470

UTILITY CONSUMPTION

Model Number	Ice Production Per Cycle		KWH per 100 LBS. 90/70	Potable Water Gal. per 100 lbs. 90/70	Condenser Water Gal. per 100 lbs. 90/70
	Lbs.	Cubes			
KMD-460MAH	9.6	432	5.5	18.9	N/A
KMD-460MWH	9.4	432	4.1	16.9	136

SPECIFICATIONS

Model Number	Condenser	Amperage	Min. Circuit Ampacity	Shipping Weight
KMD-460MAH	Air-Cooled	10.0	15A	170 lbs.
KMD-460MWH	Water-Cooled	8.5	15A	170 lbs.

*KM CUBE DIMENSIONS

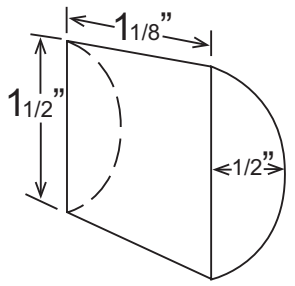

*approximate size in inches, image not to scale

ELECTRICAL & PLUMBING/KMD-460M_H

- 115/60/1
- 15 amp Max Fuse/HACR Breaker Size
- Icemaker Water Supply Line: Minimum 1/4" Nominal ID Copper Water Tubing or Equivalent
- Icemaker Drain Line: Minimum 3/4" Nominal ID Hard Pipe or Equivalent
- Water-Cooled Model (Lines Must Be Independent of Icemaker)
- Condenser Water Supply Line: Minimum 1/4" Nominal ID Copper Water Tubing or Equivalent
- Condenser Drain/Return Line: Minimum 1/4" Nominal ID Hard Pipe (open drain system) or Copper Water Tubing (closed loop system) or Equivalent

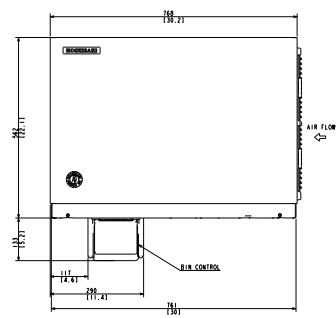

FRONT VIEW (Air-cooled)

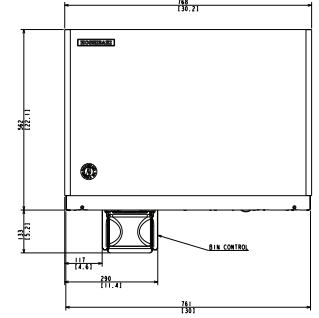

FRONT VIEW (Water-cooled)

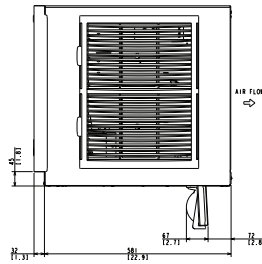

SIDE VIEW (Air-cooled)

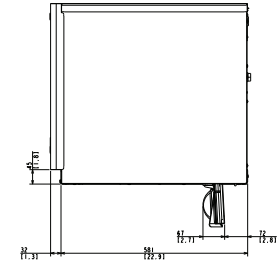

SIDE VIEW (Water-cooled)

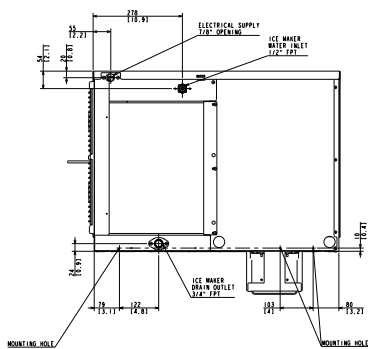

BACK VIEW (Air-cooled)

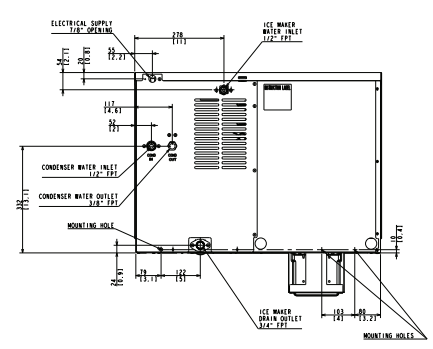

BACK VIEW (Water-cooled)

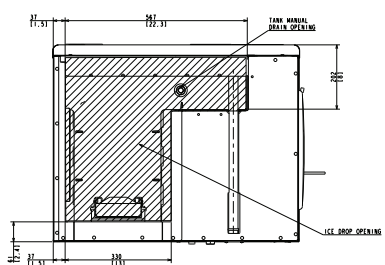

BOTTOM VIEW (Air-cooled)

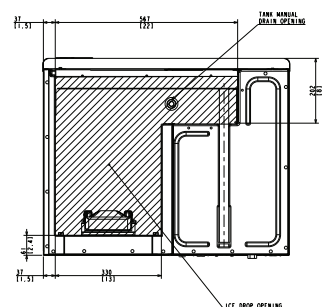

BOTTOM VIEW (Water-cooled)

OPERATING LIMITS

- Ambient Temp Range 45 - 100°F
- Water Temp Range 45 - 90°F
- Water Pressure 10 - 113psig
- Voltage Range 104 - 127V

SERVICE

- Panels easily removed and all components accessible for service.
- Removeable/cleanable air filters. (Air-Cooled model only)

© HOSHIZAKI AMERICA, INC.

