

KML-631M_H

LOW-PROFILE MODULAR CRESCENT CUBER

Item # _____

Project: _____

Qty: _____
 *AutoCad available on KCL

KML-631M_H
 I/13
 Item # 13192

CUBER DIMENSIONS W x D x H

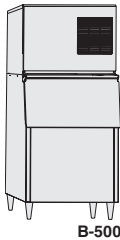
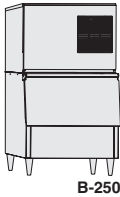

KML-631M_H
 30 x 27^{3/8} x 26



KML-631MAH
 Air-Cooled
 Shown on an optional
 B-500

KML-631MWH
 Water-Cooled

KML-631MRH
 Remote Air-Cooled

- Up to 636 lbs. of ice production per 24 hours
- Durable stainless steel exterior
- Individual crescent cube
- Protected by H-GUARD Plus Antimicrobial Agent 
- CycleSaver® Design 
- EverCheck® alert system 
- Stainless steel evaporator
- Removable air filters (Air-cooled models only)
- R-404A Refrigerant

KM CUBE DIMENSIONS

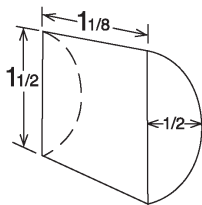

Warranty

Valid in United States, Canada, Puerto Rico, & U.S. Territories. Contact factory for warranty in other countries.

- Three Year** - Parts & Labor on entire machine.
- Five Year** - Parts & Labor on: Evaporator
- Five Year** - Parts on: Compressor, air-cooled condenser coil.



HOSHIZAKI

DIMENSIONS
W x D x H
KML-63IM_H
30 x 27^{3/8} x 26

KML-63IM_H LOW-PROFILE MODULAR CRESCENT CUBER

- Air-cooled
- Water-cooled
- Remote Air-cooled

AIR-COOLED

Water Temp ° F.	50°	70°	90°
Air Temp ° F.			
70°	575	552	515
80°	558	522	481
90°	552	497	457

WATER-COOLED

Water Temp ° F.	50°	70°	90°
Air Temp ° F.			
70°	632	631	593
80°	632	631	572
90°	631	630	579

REMOTE AIR-COOLED

Water Temp ° F.	50°	70°	90°
Air Temp ° F.			
70°	636	622	578
80°	626	604	545
90°	622	589	535

UTILITY CONSUMPTION

Model Number	Ice Production Per Cycle		KWH per 100 LBS. 90/70	Potable Water Gal. per 100 lbs.	Condenser Water Gal. per 100 lbs.
	Lbs.	Cubes			
KML-631MAH	9.0	480	6.2	26.0	N/A
KML-631MWH	9.7	480	4.4	24.8	119
KML-631MRH	9.4	480	5.3	24.0	N/A

SPECIFICATIONS

Model Number	Condenser	Amperage	Min. Circuit Ampacity	Shipping Weight
KML-631MAH	Air-Cooled	7.6	20 A	220 lbs.
KML-631MWH	Water-Cooled	6.8	20 A	217 lbs.
KML-631MRH	Remote Air-Cooled	7.8	20 A	220 lbs.

STORAGE BINS

Model Number	Application Capacity	ARI-Rated Capacity
B-250	250 lbs.	230 lbs.
B-500	500 lbs.	360 lbs.
B-700	700 lbs.	550 lbs.
B-800	800 lbs.	600 lbs.
B-900	900 lbs.	660 lbs.
B-1150	1150 lbs.	N/A
B-1300	1275 lbs.	N/A
B-1500	1500 lbs.	N/A
B-1650	1605 lbs.	N/A

ELECTRICAL & PLUMBING/KML-63IM_H

- 208-230/60/1 (3 wire with dedicated neutral for 115V)
- 20 Amp Max Fuse/HACR Breaker Size
- 3/8" OD copper or equivalent independent potable water supply
- 3/4" FPT independent drain connection



© HOSHIZAKI AMERICA, INC.

618 Hwy. 74 S., Peachtree City, GA 30269

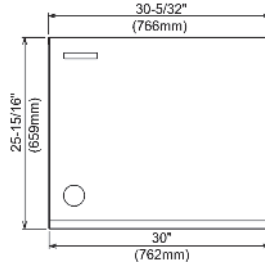

FRONT VIEW

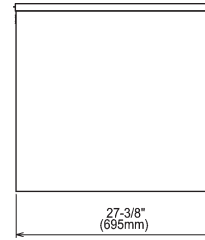

SIDE VIEW

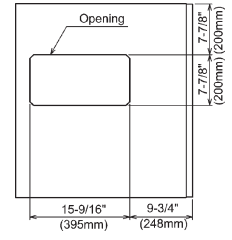

ICE DROP ZONE

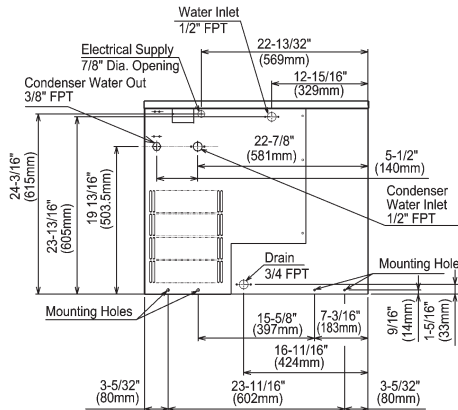

WATER-COOLED UNIT

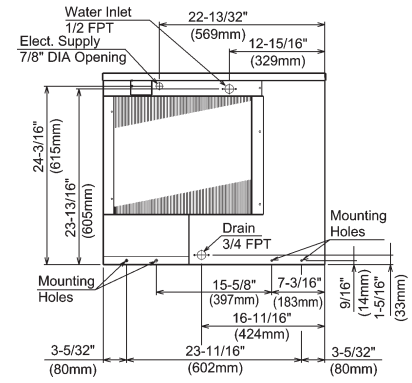

AIR-COOLED UNIT

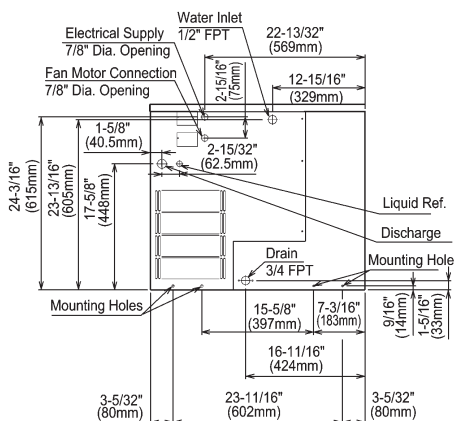

REMOTE AIR-COOLED UNIT

URC-9F Remote Condenser (Sold Separately)
For Use with KML-631MRH

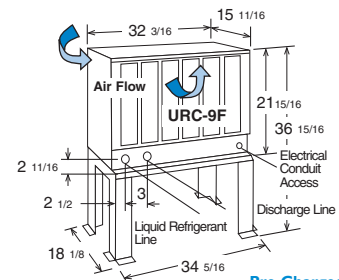

Pre-Charged Tubing Kits

- (Sold Separately)
- 20' R404-2068-2
- 35' R404-3568-2
- 55' R404-5568-2



Voltage supply for the URC Remote Condenser is supplied from the Ice Maker. No additional circuit is required.

OPERATING LIMITS

- Ambient Temp Range 45 - 100°F
- Water Temp Range 45 - 90°F
- Water Pressure 10 - 113psig
- Voltage Range 187 - 253V

SERVICE

- Panels easily removed and all components accessible for service.
- Removable/cleanable air filters (Air-cooled models only)

CONDENSING UNIT

- Voltage Range 104 - 127V
- Ambient Temp Range -22 - 122°F

TEL 1-800-428-6087

FAX 1-800-345-1325

www.hoshizaki.com

Printed in U.S.A.

A City Discount

