

KMS-822MLH

SERENITY SERIES

CUBER ICE MACHINE

Item # _____

Project: _____

Qty: _____

*AutoCad available on KCL

KMS-822MLH

6/11

Item # 13269

CUBER DIMENSIONS

W x D x H

KMS-822MLH

22 x 24^{5/8} x 28

CONDENSING UNIT DIMENSIONS

W x D x H

Installation Dimension*

SRK-10H

52^{3/8} x 19^{1/2} x 43

*Dimensions include legs

Actual Dimension



SRK-10H

50 x 17 x 28

KMS-822MLH

Remote Air-Cooled
Shown on an optional
Lancer 22" Dispenser



- Up to 839 lbs. of ice production per 24 hours
- Ice on beverage design
- Less heat in the kitchen
- Minimized noise
- Durable stainless steel exterior
- Individual crescent cube
- Protected by *H-GUARD Plus* Antimicrobial Agent 
- CycleSaver® Design 
- EverCheck® alert system 
- Stainless steel evaporator
- CFC / HFC Free foam
- R-404A Refrigerant
- *Not recommended for side-by-side application*

Warranty

Valid in United States, Canada, Puerto Rico, & U.S. Territories. Contact factory for warranty in other countries.

Three Year - Parts & Labor on entire machine.

Five Year - Parts & Labor on: Evaporator.

Five Year - Parts on: Compressor, air-cooled condenser coil.



ISO 9001-5:2008

© HOSHIZAKI AMERICA, INC.

618 Hwy. 74 S., Peachtree City, GA 30269

TEL 1-800-438-6087

FAX 1-800-345-1325

www.hoshizaki.com



KMS-822MLH SERENITY SERIES

DIMENSIONS
W x D x H
KMS-822MLH
22 x 24^{5/8} x 28

**Installation Dimension*
SRK-10H**
52^{3/8} x 19^{1/2} x 43
*Dimensions include legs

**Actual Dimension
SRK-10H**
50 x 17 x 28

REMOTE AIR-COOLED

Water Temp ° F.	50°	70°	90°	
Air Temp ° F.	70°	839	820	769
	80°	824	795	730
	90°	820	774	714

UTILITY CONSUMPTION

Model Number	Ice Production Per Cycle		KWH per 100 LBS. 90/70	Potable Water Gal. per 100 lbs. 90/70	Condenser Water Gal. per 100 lbs. 90/70
	Lbs.	Cubes			
KMS-822MLH with SRK-10H	13.6	624	5.58	19.3	N/A

SPECIFICATIONS

Model Number	Condenser	Amperage	Min. Circuit Ampacity	Shipping Weight
KMS-822MLH with SRK-10H	Remote Air-Cooled	11.5	20	152 lbs. 273 lbs.

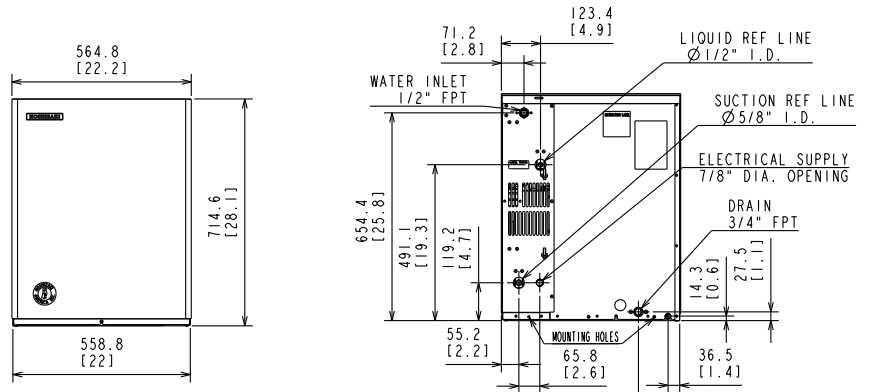

FRONT VIEW

BACK VIEW

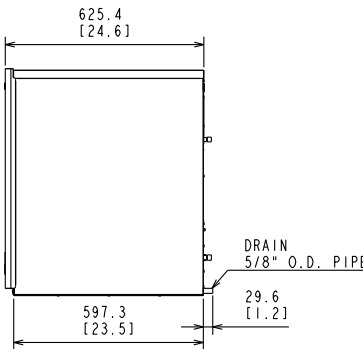

SIDE VIEW

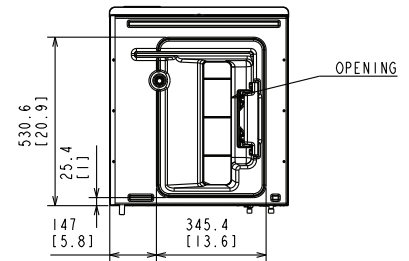

BOTTOM VIEW

SRK-10H Remote Condensing Unit (Sold Separately)
For Use with KMS-822MLH

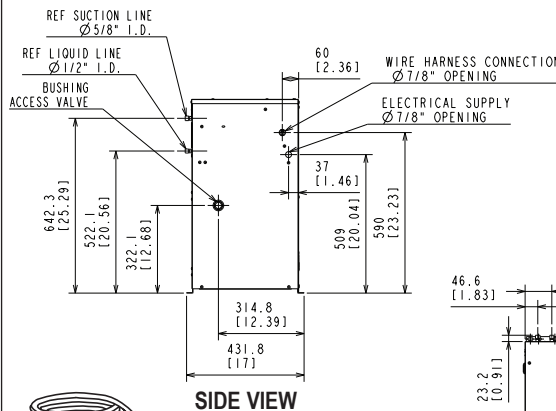

SIDE VIEW

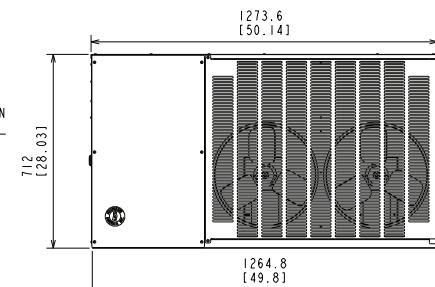

FRONT VIEW

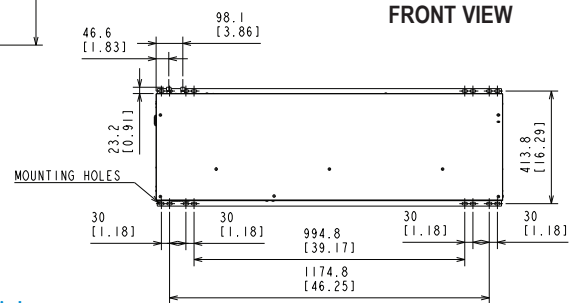

TOP VIEW



Tubing Kits - REQUIRES FIELD BRAZING

(Sold Separately)
• 25° HS-0250
• 35° HS-0251
• 55° HS-0252

Voltage supply for the KMS Ice Maker is supplied from the SRK Remote Condenser.

ELECTRICAL & PLUMBING/KMS-822MLH

- 115V/60/1 - Voltage supply for the KMS Ice Maker is supplied from the SRK Remote Condenser
- 1/2" FPT copper or equivalent independent potable water supply
- 3/4" FPT independent drain connection

CONDENSER UNIT/SRK-10H

- 208-230/60/1 (3 wire with neutral for 115V)
- 20 amp Max Fuse/HACR Breaker Size

OPERATING LIMITS

- Ambient Temp Range 45 - 100°F
- Water Temp Range 45 - 90°F
- Water Pressure 10 - 113psig
- Voltage Range 187 - 253V

SERVICE

- Panels easily removed and all components accessible for service.

CONDENSING UNIT

- Voltage Range 187 - 253V
- Ambient Temp Range -20 - 122° F



© HOSHIZAKI AMERICA, INC.

618 Hwy. 74 S., Peachtree City, GA 30269

TEL 1-800-438-6097

FAX 1-800-345-1325

www.hoshizaki.com

Printed in U.S.A.

A City Discount

