



Project:

Item Number:

Quantity:

LIGHT AND MEDIUM DUTY SLICERS



40803 Light-Duty Slicer

MODELS

- 40802 9" Light-Duty Electric Slicer
- 40803 10" Light-Duty Electric Slicer
- 40804 12" Medium-Duty Electric Slicer

FEATURES

- Space-saver design with smaller footprint for tight areas
- Ideal for casual slicing needs such as for coffee shops, small restaurants, sub shops, and delis

DESCRIPTION

From small coffee shops to supermarket delis, or soft vegetables to frozen meats and cheeses, Vollrath offers the perfect slicer to fit your needs. Light and medium duty slicers feature a space-saver design with a smaller footprint for tight areas. They are ideal for casual slicing needs such as for coffee shops, small restaurants, sub shops, and delis.

Agency Listings



Due to continued product improvement, please consult www.vollrathco.com for current product specifications.

Approvals

<p style="text-align: right;">Date:</p>
--



Setting the Standard™

www.vollrathco.com

The Vollrath Company, L.L.C.
 1236 North 18th Street
 Sheboygan, WI 53081-3201 U.S.A.
 Customer Service: 800.628.0830
 Canada Customer Service: 800.695.8560
 Main Fax: 800.752.5620 or 920.459.6573

Technical Services: 800.628.0832
 Technical Services Fax: 920.459.6573

LIGHT AND MEDIUM DUTY SLICERS

MODELS		
40802	9" Light-Duty Electric Slicer	
40803	10" Light-Duty Electric Slicer	
40804	12" Medium-Duty Electric Slicer	

DIMENSIONS

Dimensions shown in inches (cm).

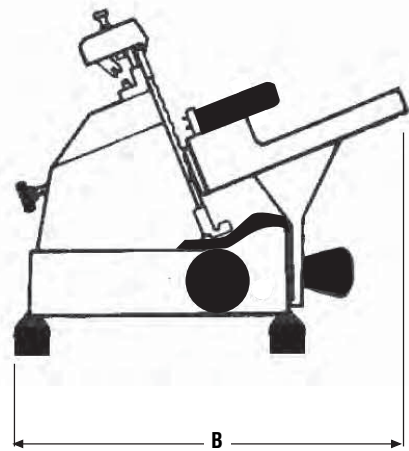
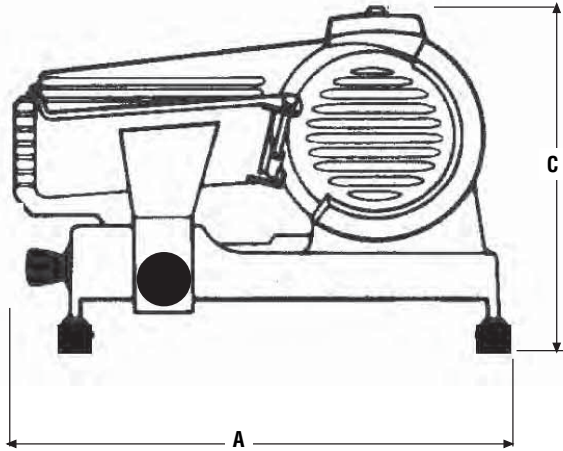

SPECIFICATIONS

Item	Dimensions			Drive	HP	Voltage	Amps	Plug
	(A) Width	(B) Length	(C) Height					
40802	16 (40.6)	18 (45.7)	15 (38.1)	Belt	0.25	110	1.2	5-15P
40803	17 (43.2)	21 (53.3)	15 (38.1)	Belt	0.3	110	1.5	5-15P
40804	18 (45.7)	22 (55.9)	16 (40.6)	Belt	0.3	110	1.5	5-15P

Receptacle

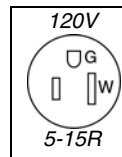

www.vollrathco.com

The Vollrath Company, L.L.C.
 1236 North 18th Street
 Sheboygan, WI 53081-3201 U.S.A.
 Customer Service: 800.628.0830
 Canada Customer Service: 800.695.8560
 Main Fax: 800.752.5620 or 920.459.6573

Technical Services: 800.628.0832
 Technical Services Fax: 920.459.6573