

E**ELECTRIC TWO
BURNER RANGE**
 JOB NAME: _____
 ITEM NO.: _____
 NO. REQUIRED: _____
**MODEL:** M18-HPE
SIZE: 18" Wide x 33" Front-to-Back
 (457mm Wide x 838mm Front-to-Back)
DESCRIPTION:

Shall be Market Forge Model M18-HPE Electric Two Burner Range mounted on a 28" (711mm) high cabinet base. Heating elements shall be 8.7" diameter (220mm) cast iron surfaces, located front and rear on raised cabinet top. Each element shall be 2.6 KW (5.2 KW total).

Infinity controls with individual pilot lights shall be mounted on front of raised cabinet top.

Polished stainless steel cabinet base 18" (457mm) wide shall be of modular design to match other Market Forge cooking equipment. Shall be equipped with 6" (152mm) stainless steel legs and adjustable bullet feet, and a hinged door with magnetic latch.

OPERATION SHALL BE BY:

- 208 VAC, 60Hz, Three/Single Phase
- 240 VAC, 60 Hz, Three/Single Phase

SERVICE CONNECTIONS
Electrically Operated

EP	Power Supply -Use wire suitable for at least 90°C. Unit supplied for 3-Phase operation, may be converted to 1-Phase. All models rated at 5.2KW (2.6KW each Element). Nominal amp per line wire.			
	Voltage	Line 1	Line 2	Line 3
	208V, 1 Phase	25.0	25.0	--
	240V, 1 Phase	21.7	21.7	--
	208V, 3 Phase	25	12.5	12.5
	240V, 3 Phase	21.7	10.9	10.9

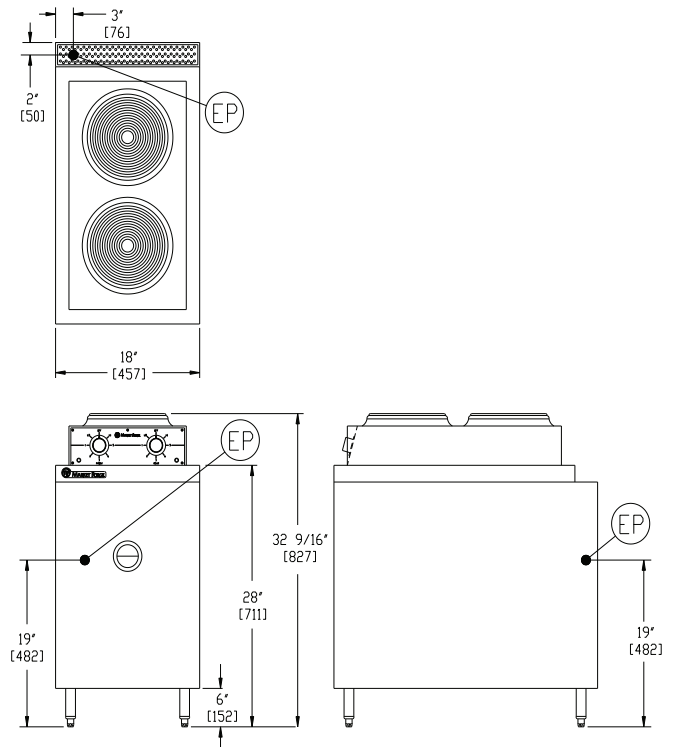

The manufacturer reserves the right to modify materials and specifications without notice.

It is our policy to build equipment which is design certified by U.L., A.S.M.E., N.S.F. and C.S.A. However, a continuing program of product improvement makes it necessary to submit new models to the agencies as they are developed and consequently not all models bear the appropriate agency labels at all times.

 SPEC SHEET: S-1636N
 02/08

FOOD SERVICE EQUIPMENT
 Two Burner Range

PRINTED IN U. S. A.

MARKET FORGE
 INDUSTRIES INC.

 35 Garvey Street • Everett • MA • 02149
 Tel: (617) 387-47100 • Fax: 1-800-227-2659 (Ex. MA) • (617) 387-4456 (MA and Overseas)
 E-Mail: CUSTSERV@mfi.com • Website: www.mfi.com

A City Discount