



MBGR26H



MBGR70H



## MBGR SERIES

### Bottom Mounted Swinging Glass Door Reach-In Refrigerators

- MODELS**
- MBGR26H
  - MBGR70H

C-UL listing applies to MBGR26H only. This equipment is intended for storage and display of non-potentially hazardous bottled or canned products only.

## FEATURES

### CONSTRUCTION

- Black painted steel exterior
- White painted steel interior
- Foamed-in-place with low ODP polyurethane insulation
- Top graphic panel backlit by fluorescent lights (graphics not supplied)
- Interior vertical fluorescent lighting
- Wall thickness:
  - MBGR26H ..... 1.6"
  - MBGR70H ..... 2"
- Adjustable legs for leveling
- Four adjustable heavy-duty vinyl-coated shelves per door

### DOORS

- Self-closing
- Hold open feature
- Double pane glass with layer of patented transparent thermal insulation film between glass panes provides superior insulation without the weight of triple pane glass
- Standard door swing configuration:
  - MBGR26H ..... hinged right
  - MBGR70H ..... left door hinged left, middle door hinged right, right door hinged right
- Door width:
  - MBGR26H ..... 28"
  - MBGR70H ..... 25½"

### REFRIGERATION

- Self-contained bottom mount refrigeration system
- Capillary tube to control refrigerant flow
- Fabric condensation kit uses wicks to draw condensate from the drain pan for faster removal
- Refrigerant: R-134a
- Temperature range: 32° to 40°F (0° to 4° C)

### WARRANTY

- **Standard limited three year parts and labor**
- **Additional two year coverage on compressor part**

### TECHNICAL SPECIFICATIONS

MODEL	DIMENSIONS (in.)			DIMENSIONS (mm)			VOLTS	AMPS	UNIT H.P.	NO. OF DOORS	NO. OF SHELVES	STANDARD SHELF SIZE (in inches)	CAP. CU. FT.	SHIP CU. FT.	SHIP WT. (LB/KG)
	L	D*	H	L	D*	H									
MBGR26H	28 1/2	33 1/4	79	724	845	2007	115	3.9	1/3	1	4	24.2 x 23.1	24.0	45.8	353/160
MBGR70H	78	33	79 1/2	1981	838	2019	115	11.9	3/5	3	12	25.2 x 22 (center), 22 x 22.1 (left, right)	72.0	130.9	696/316

\*Depth includes door handle.

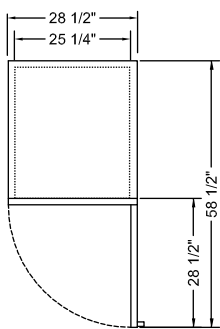

MBGR26H  
PLAN VIEW

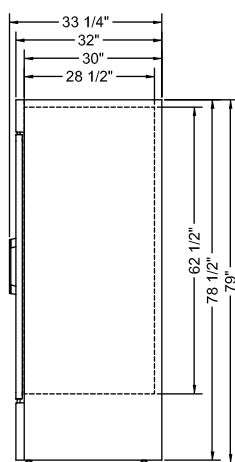

MBGR26H  
SIDE VIEW

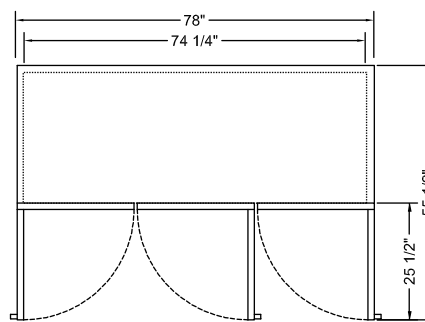

MBGR70H  
PLAN VIEW

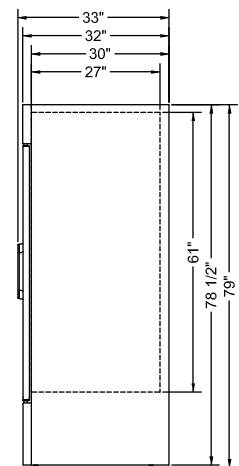

MBGR70H  
SIDE VIEW

### LISTINGS



C-UL listing applies to MBGR26H model only.

This equipment is intended for storage and display of non-potentially hazardous bottled or canned products only.

### HOOKUP

All models via plug in, 9.8 foot long flexible three wire 14/3 cord with molded plug.

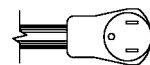

NEMA 5-15P

### BID SPECIFICATIONS

Item no. MBGR\_\_\_\_\_. Provide \_\_\_\_\_ Bottom Mounted Glass Door Reach-in(s), Master-Bilt model no. MBGR\_\_\_\_\_.

Reach-in will be constructed of black painted steel exterior and white painted steel interior. Standard features will include vinyl-

coated welded wire shelves and doors with double pane glass.

The refrigeration system will be bottom mounted and self-contained. Refrigerant will be R-134A. The temperature range will be 32° to 40°F (0° to 4° C).

Reach-in to have standard limited three year parts and labor with additional two year coverage on compressor part.

Reach-in to be UL and ETL Sanitation listed. MBGR26H will also be C-UL listed.

**NOTE:** Cabinet designed for optimum performance in air-conditioned area at 75°F ambient and 55% relative humidity. All specifications subject to change without notice.