





Turbofan E25

Half Size Electric Convection Oven

-  Commercial construction
-  2 half pan capacity
-  60 minute bake timer
-  Stainless steel outer
-  Insulated porcelain inner
-  Twin pane glass door
-  Internal lighting



E25



Order Toll Free 1800 551 8795

E25

Unit shall be a Moffat electrically heated Turbofan convection oven E.T.L listed (UL Std 197), NSF listed (NSF - 4). The oven shall have a one piece vitreous porcelain enamel oven liner, stainless steel top and sides and twin pane glass door. Oven liner shall be insulated on all sides and have capacity for two half size sheet pans. A single speed fan shall evenly circulate air internally. The oven shall be controlled by a mechanical thermostat with a range from 120°F to 480°F, a 60 minute bake timer, and oven light switch. Oven shall be able to be bench mounted on 4" legs. Oven shall be fitted with a NEMA 5-15P cordset.

Turbofan E23

Half Size Electric Convection Oven

CONSTRUCTION

Stainless steel top and sides
 Porcelain oven interior
 Toughened twin pane door glass
 Strong and stylish door handle
 2 half pan capacity (wire racks included)
 Fully insulated
 Porcelain control panel
 Fully enclosed motor at rear

CONTROLS

On/off switch
 Mechanical thermostat, variable between
 120°F to 480°F
 Low velocity fan system
 Oven light

CLEANING AND SERVICING

Fully removable racks and fan baffle
 Easy clean surfaces
 Access to all controls from front panel
 No tools required to replace lamps
 Removable gaskets - no tools required

SPECIFICATIONS

Electrical requirements
 110V, 60Hz, 1P+N+E, 1.6kW, 13.3A
 NEMA 5-15P cordset fitted

External Dimensions

Width 28 3/8" (720mm)
 Height 16 7/8" (430mm)
 Depth 23 5/8" (600mm)

Internal Dimensions

Width 18 1/2" (470mm)
 Height 10 5/8" (270mm)
 Depth 15 1/8" (385mm)

Oven Volume

1.8 ft³ (0.05m³)

Oven Rack Dimensions

Width 18" (460mm)
 Depth 13" (330mm)

Nett Weight

86lbs (39kg)

Packing Data

119lbs (54kg)
 11 ft³ (0.30m³)
 Width 29 1/8" (740mm)
 Height 22 7/8" (580mm)
 Depth 28" (710mm)

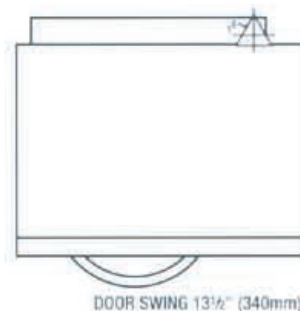
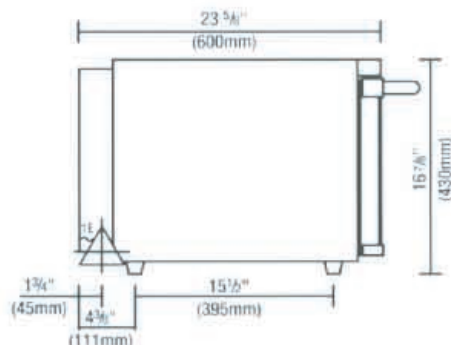
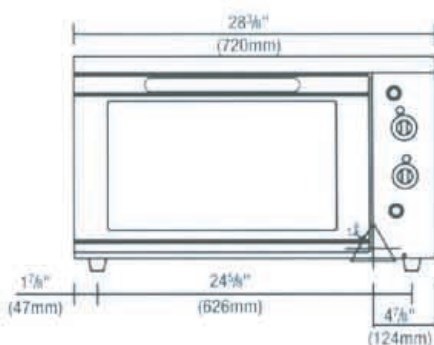

U.S.A
Moffat Inc
 3765 Champion Boulevard
 Winston-Salem
 North Carolina 27105
 Call Free 1800 551 8795
 Ph 336-661 0257
 Fax 336-661 9546
 Email sales@moffat.com
 www.moffat.com

Canada
Lessard Agencies Ltd
 PO Box 97
 Stn D Toronto
 Ontario M6P 3J5
 Canada
 Call Free 1888 LESSARD
 Ph 416-766 2764
 Fax 416-760 0394

Australia
Moffat Pty Limited
 740 Springvale Rd
 Mulgrave
 Victoria 3170
 Australia
 Ph 03-9518 3888
 Fax 03-9518 3833
 Email vsales@moffat.com.au
 www.moffat.com.au

New Zealand
Moffat Limited
 16 Osborne St
 PO Box 10-001
 Christchurch
 New Zealand
 Ph 03-389 1007
 Fax 03-389 1276
 Email sales@moffat.co.nz
 www.moffat.co.nz

United Kingdom
Blue Seal Limited
 Units 6-7 Mount St
 Business Park
 Birmingham B7 5QU
 England
 Ph 0121-327 5575
 Fax 0121-327 9711
 Email sales@blue-seal.co.uk
 www.blue-seal.co.uk



ISO 9001
 All Turbofan products are designed and manufactured by Moffat Ltd using the internationally recognised ISO 9001 quality management system, covering design, manufacture and final inspection, ensuring consistent high quality at all times.

