

E**ONE 10 GALLON
ELECTRIC TILTING KETTLE**

JOB NAME: _____

ITEM NO.: _____

NO. REQUIRED: _____

- MODELS:**
- MT10E24A
 - MT10E36A
 - MT10E42/48A

SIZE: 36" x Wide x 33" Front-to-Back
(914mm Wide x 838mm Front-to-Back)

DESCRIPTION:

Will be a Market Forge Model _____, tilting steam jacketed trunnion kettle. Kettle will be mounted on a 28" (711mm) high cabinet base. Hot and cold water fill faucet, depressed area, drains, and steam control valves will be located on stainless steel marine-edged countertop. A 4" (102mm) deep 12" x 10" (305mm x 254mm) clean-up pan with removable splash guard will be standard. (*Splash guard will be removable so that it may also be attached to a food receiving pan.*) Kettles are made from #316 stainless steel and will be A.S.M.E.- approved and National Board Registered.

Cabinet base, constructed of stainless steel frame, which houses the electric steam generator, will be of modular design to match other Market Forge cooking equipment. Base with stainless steel frame will be equipped with 6" (152mm) stainless steel legs and adjustable bullet feet, reinforced die-formed stainless steel marine-edged countertop, and hinged doors with magnetic latches. Unit will be polished stainless steel.

CAPACITY:

- MT10E - 10 Gallon (38 liters)

OPERATION SHALL BE BY:

Electrically operated, 15 PSI (1kg/cm²), built in accordance with A.S.M.E. codes, equipped for operation with:

- 208 Volt, 3 phase
- 240 Volt, 3 phase
- 480 Volt, 3 phase (optional at extra cost)
- 220/380 Volt
- 240/415 Volt, 50 Hz, 3 phase, 15 Amps



Steam generator will be automatically filled with hot water and brought t 15 PSI (1.0kg/cm²) pressure when heat and water switches are turned on and automatically drained under pressure when switches are turned off. Cold water condenser will automatically condense exhaust steam into water before releasing it to drain.

STANDARD FEATURES:

- Safety Valve.
- Low Water Cut-Off.
- Water Strainer.

OPTIONAL AT EXTRA COST:

- 480 VAC, 3 pH.
- One-piece Lift-off Stainless Steel Cover.
- Clean-up brush.
- Total Concept Boiler Descaling Chemical.
- Stainless Steel Wire Basket.
- Steam Take-Off kit
- Total Concept Boiler Descaling Chemical

* The manufacturer reserves the right to modify materials and specifications without notice.

SPEC SHEET: S-2386B
05/12FOOD SERVICE EQUIPMENT
One 10 Gallon Tilting Kettle

MARKET FORGE
INDUSTRIES INC.

35 Garvey Street • Everett • MA • 02149
Tel: (617) 387-4100 • Fax: 1-800-227-2659 (Ex. MA) • (617) 387-4456 (MA and Overseas)
E-Mail: CUSTSERV@mfi.com • Website: www.mfi.com

E**ONE 10 GALLON
ELECTRIC TILTING KETTLE**

DETAILS & DIMENSIONS

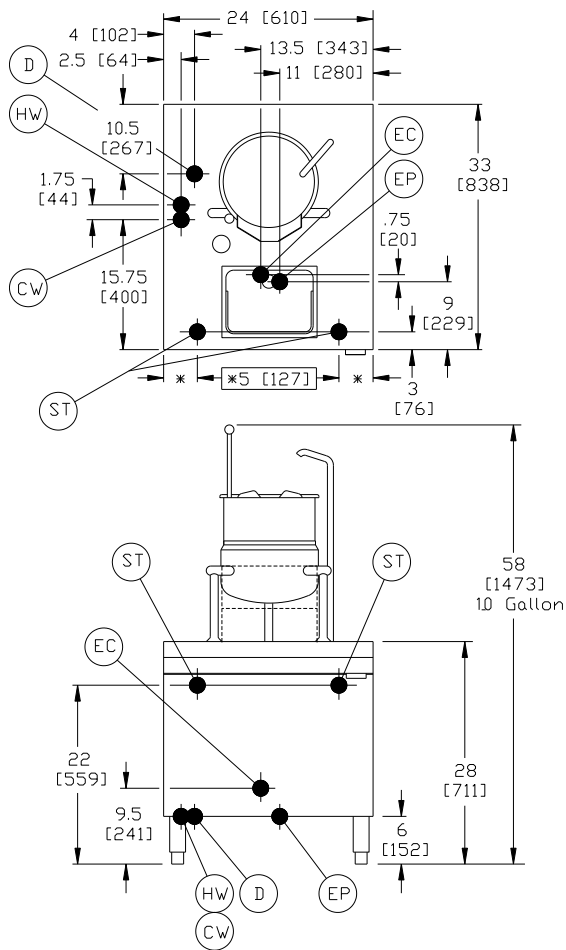
**SERVICE CONNECTIONS****Electrically Operated**

| | | | | | |
|-----|--|------|------|------|------|
| EP | Power Supply—Use wire suitable for at least 90°C. Nominal amp per line wire: | | | | |
| | Volts | 24kW | 36kW | 42kW | 48kW |
| | | 3pH | 3pH | 3pH | 3pH |
| | 208 (197-219) | 66 | 100 | 117 | -- |
| | 240 (220-240) | 60 | 91 | -- | 116 |
| | 480 (360-500) | 32 | 47 | -- | 58 |
| | Details of other electrical systems available upon request. | | | | |
| HW | Hot Water — 3/8" (10mm) N.P.T. female for hot water to kettle fill faucet. Max. 50 PSI (3.5kg/cm ²) and min. 25 PSI (1.8kg/cm ²) water pressure. | | | | |
| CW | Cold Water — 3/8" (10mm) N.P.T. female for cold water to kettle fill faucet. Max. 50 PSI (3.5kg/cm ²) and min. 25 PSI (1.8kg/cm ²) water pressure. | | | | |
| HWK | 1/2" (13mm) O.D. tubing for hot water to kettle fill faucet. | | | | |
| CWK | 1/2" (13mm) O.D. tubing for cold water to kettle fill faucet. | | | | |
| D | Drain — Pipe full 2" (50mm) N.P.T. female to flush floor drain. DO NOT MAKE SOLID CONNECTION TO FLOOR DRAIN. | | | | |
| EC | Electrical Connection - 115 VAC, 60 Hz, 2 amps, 1/2" (13mm) conduit connection or equivalent. Use wire suitable for at least 90°C. | | | | |
| ST* | Steam Take-Off — 3/4" (19mm) N.P.T. female for incoming steam from Market Forge boiler. | | | | |

* Steam supply connection available on either side of cabinet base.

CAUTION:

Before connecting water to this unit, water supply should be analyzed to make sure hardness is no greater than 2.0 grains per gallon and pH level is within the range of 7.0-8.5. Water that fails to meet these standards should be treated by installation of water conditioner. **EQUIPMENT FAILURE CAUSED BY INADEQUATE WATER QUALITY IS NOT COVERED UNDER WARRANTY.**

NOTES: Units supplied for use in Canada require only one electrical connection at "EP" for both power and control circuits.

PVC and CPVC pipe are not acceptable materials for drains.

The only available space to supply utilities to the steam generator is the 6" (152mm) space between the floor and the cabinet base. Allow 3" (76 mm) spacing from side wall and 6" (152mm) from rear wall if adjoining wall is combustible.

It is our policy to build equipment which is design certified by A.G.A., U.L., A.S.M.E., N.S.F., C.G.A. and C.S.A. However, a continuing program of product improvement makes it necessary to submit new models to the agencies as they are developed and consequently not all models bear the appropriate agency labels at all times.

SPEC SHEET: S-2386B
05/12**FOOD SERVICE EQUIPMENT**
One 10 Gallon Tilting Kettle**MARKET FORGE**
INDUSTRIES INC.

PRINTED IN U.S.A.

35 Garvey Street • Everett • MA • 02149
Tel: (617) 387-4100 • Fax: 1-800-227-2659 (Ex. MA) • (617) 387-4456 (MA and Overseas)
E-Mail: CUSTSERV@mfi.com • Website: www.mfii.com

A City Discount