

COLDIN-3™ MSC-A SERIES

Curved Lid Display Freezers

MODELS

- MSC-31AA
- MSC-41AA
- MSC-49AA
- MSC-66AN



MSC-66AN

MSC-49AA



FEATURES

CONSTRUCTION

- Standard interior LED lighting with separate on/off switch
- Curved tempered glass sliding lids
- White zinc-coated baked-on enamel steel exterior
- Painted white powder-coated steel interior
- Removable rubber bumper guards on grille side
- Heavy-duty casters, two locking
- Bottom drain with plug
- Lid lock and keys
- The unobtrusive frame around the glass lids ensures a highly visible display
- External analog thermometer display
- Control panel with adjustable temperature range of +10 to -18°F
- Low energy consumption

REFRIGERATION

- Refrigerant: R290
- Temperature range: -18° to 10°F (-27° to -12°C)

WARRANTY

- Standard one year parts and labor

OPTIONS

- Extra basket dividers
- Replacement baskets

STANDARD BASKETS

MSC-A models are supplied with equally-sized angled baskets and one adjustable horizontal divider per basket.

MODEL	NO. OF BASKETS/DIVIDERS
MSC-31AA	3/3
MSC-41AA	4/4
MSC-49AA	5/5
MSC-66AN	6/6

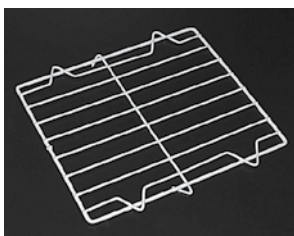

Horizontal divider

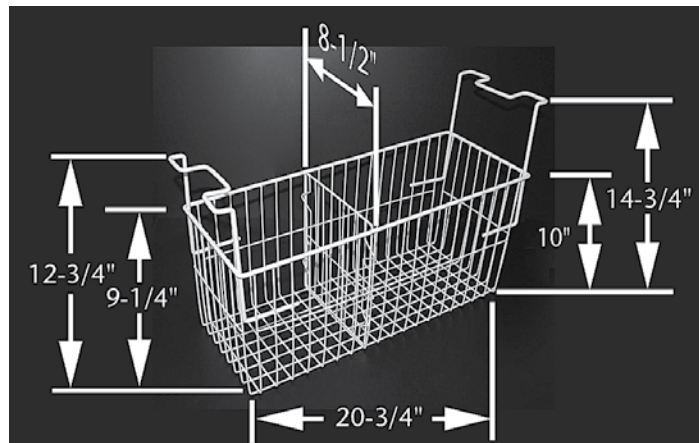

TECHNICAL SPECIFICATIONS

Models	MSC-31AA	MSC-41AA	MSC-49AA	MSC-66AN
Crated Weight (lbs) (kg)	146 (66)	150 (68)	181 (82)	231 (105)
Crated Height (in) (mm)	35-1/4 (895)	35-1/4 (895)	35-1/4 (895)	40 (1016)
Crated Width (in) (mm)	34-5/8 (880)	42-1/2 (1080)	52 (1320)	69-1/2 (1765)
Crated Depth (in) (mm)	30-3/8 (770)	30-3/8 (770)	30-3/8 (770)	30-1/2 (775)
Interior Height (in) (mm)	21 (533)	21 (533)	21 (533)	21 (533)
Interior Width (in) (mm)	25-7/8 (657)	35-3/8 (899)	43-1/4 (1099)	60-7/8 (1546)
Interior Depth (in) (mm)	21-1/2 (546)	21-1/2 (546)	21-1/2 (546)	21-1/2 (546)
Overall Height (in) (mm)	33-1/2 (850)	33-1/2 (850)	33-1/2 (850)	33-1/2 (851)
Overall Width (in) (mm)	31-1/2 (800)	39-3/8 (1000)	48-7/8 (1240)	66-1/2 (1689)
Overall Depth (in) (mm)	27-3/8 (694)	27-3/8 (694)	27-3/8 (694)	27-3/8 (695)
Gross Cubage (CuFt) (L)	7.2 (203)	9.7 (274)	12.7 (359)	20.3 (574.8)
Number of Baskets*	3	4	5	6
Number of Casters	4	4	4	4
Condensing Unit Size	1/3 HP	3/8 HP	3/8 HP	3/4 HP
Refrigerant	R290	R290	R290	R290
Electrical Characteristics	115/60/1	115/60/1	115/60/1	115/60/1
NEMA Plug Configuration	5-15P	5-15P	5-15P	5-15P
Total Amp Draw	1.3	1.4	2.0	4.1

* Includes 1 divider per basket.

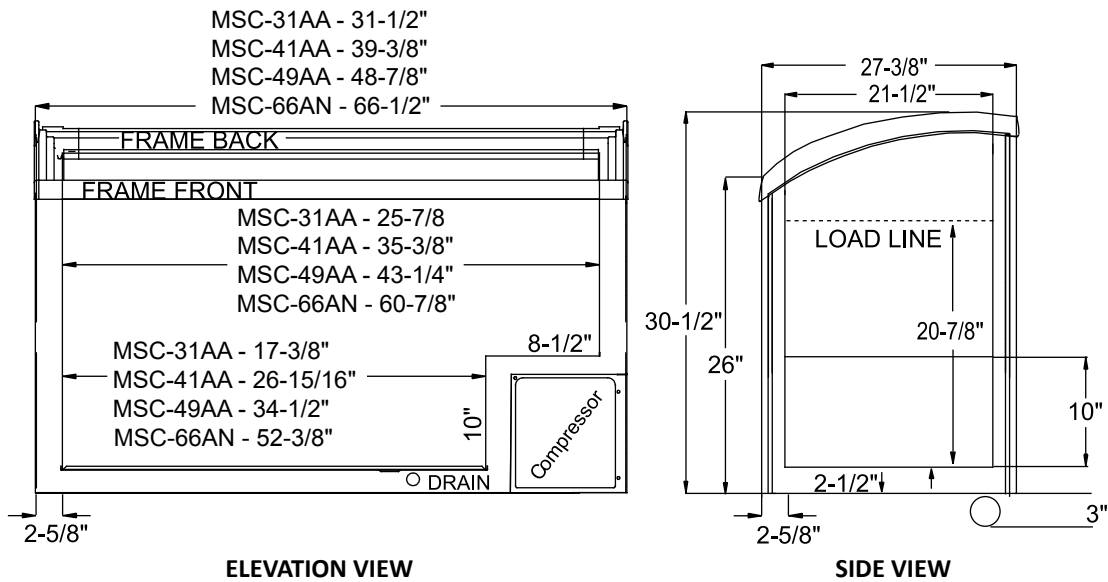

LISTINGS



HOOKUP

Via plug in, 6-1/2 foot long, flexible 3 wire
14AWG/3 cord with molded plug.



BID SPECIFICATIONS

Item no. MSC-____A

Provide _____ ()

Curved Lid Display Freezer(s)

Master-Bilt model MSC-____A.

Freezer to be constructed of a white zinc-coated baked-on enamel on steel exterior with painted white powder-coated steel interior. Freezer to be

furnished with standard LED interior lighting. Also standard with baskets, basket dividers, thermometer and lock. Additionally, it will be provided with heavy-duty casters and a defrost water drain. Lids will contain tempered safety glass.

Refrigeration system will use R290

refrigerant in all models.

The temperature range will be -18° to 10°F (-27° to -12°C).

Freezer to have standard one year parts and labor warranty.

Freezer to be ETL listed in the U.S. and Canada and ETL Sanitation listed.

**NOTE: Cabinet designed for optimum performance in air-conditioned area at 75°F ambient and 55% relative humidity.
All specifications within this publication subject to change without notice.**