



GLOBE FOOD EQUIPMENT COMPANY

Meat Choppers

CC12/CC22

Project \_\_\_\_\_ Item # \_\_\_\_\_ Quantity \_\_\_\_\_



# CC12/CC22 Meat Choppers

### Models

- CC12 #12 Meat Chopper
- CC22 #22 Meat Chopper



### Standard Features

- Powerful 1 HP (CC12) or 1 1/2 HP (CC22) high torque motor
- Direct gear-driven transmission
- Stainless steel housing, cylinder, worm gear, adjusting ring and product tray
- Permanent grease lubricated gear box
- Manual reset motor overload protection
- Forward/reverse switch
- Compact size and seamless construction
- Capacity 250 lbs/hr (CC12) or 450 lbs/hr (CC22)
- Top-mounted handle
- Rubber feet
- Seven-foot cord and plug

### Optional Accessories

- Stuffing Tube

### Standard Warranty

- One-year parts and labor

### Standard Accessories

- Knife
- Stainless steel product tray
- 1/4" (6mm) plate
- 5/16" (8mm) plate
- Plastic food pusher

Approved By: \_\_\_\_\_

Date: \_\_\_\_\_



**GLOBE FOOD EQUIPMENT COMPANY**  
www.globeslicers.com

2153 Dryden Rd.  
Dayton, OH 45439  
Phone: 937-299-5493  
Phone: 800-347-5423  
Fax: 937-299-4147



# Meat Choppers

# CC12/CC22

**Motor:** 1 HP 8 amps (CC12) or 1 1/2 HP 16 amps (CC22), 115/60/1. Manual reset motor overload protection.

**Transmission:** Precision made gears and shafts, mounted on ball bearings. Permanent grease packed sealed gear box.

**Switch:** Conveniently mounted on side of machine, with Off, Forward and Reverse positions.

**Construction:** The seamless housing, cylinder, worm gear, adjusting ring and product tray are made of stainless steel for quick and easy cleaning. Rubber feet prevent the machine from moving during operation.

**Capacity:**  
CC12: 250 lbs. of meat per hour  
CC22: 450 lbs. of meat per hour

**Cord and Plug:** Attached is a seven-foot flexible 3-wire cord and plug that fits a grounded receptacle.

## Specifications

**Worm Speed:** 170 RPM's

**Standard Equipment:** Knife, 1/4" and 5/16" plates, stainless steel product tray and plastic food pusher.

### Optional Accessories (CC12):

- Stuffing Tube
- Plate sizes available for model CC12:

<b>CP02-12</b>	1/16"	(2mm)
<b>CP04-12</b>	5/32"	(4mm)
<b>CP06-12</b>	1/4"	(6mm)
<b>CP08-12</b>	5/16"	(8mm)
<b>CP10-12</b>	3/8"	(10mm)
<b>CP12-12</b>	1/2"	(12mm)
<b>CP14-12</b>	9/16"	(14mm)
<b>CP16-12</b>	5/8"	(16mm)
<b>CP18-12</b>	11/16"	(18mm)

**\*CP00-12** stuffing plate

\* Important: This plate must be used when stuffing sausage casings.

### Dimensions: (CC12)

Net weight: 66 lbs. (29.9 kgs.)  
Shipping weight: 77 lbs. (34.8 kgs.)  
Box Dimensions:  
12"W x 18"D x 16"H  
(30.5cm x 45.7cm x 40.6cm)  
Overall Length: 16.5" (41.9cm)  
Overall Width: 9.25" (23.5cm)  
Overall Height : 16.66" (42.3cm)

### Optional Accessories (CC22):

- Stuffing Tube
- Plate sizes available for model CC22:

<b>CP02-22</b>	1/16"	(2mm)
<b>CP04-22</b>	5/32"	(4mm)
<b>CP06-22</b>	1/4"	(6mm)
<b>CP08-22</b>	5/16"	(8mm)
<b>CP10-22</b>	3/8"	(10mm)
<b>CP12-22</b>	1/2"	(12mm)
<b>CP14-22</b>	9/16"	(14mm)
<b>CP16-22</b>	5/8"	(16mm)
<b>CP18-22</b>	11/16"	(18mm)
<b>CP20-22</b>	3/4"	(20mm)

**\*CP00-22** stuffing plate

\* Important: This plate must be used when stuffing sausage casings.

### Dimensions: (CC22)

Net weight: 88 lbs. (39.9 kgs.)  
Shipping weight: 95 lbs. (43 kgs.)  
Box Dimensions:  
15"W x 23"D x 23"H  
(38.1cm x 58.4cm x 58.4cm)  
Overall Length: 18.25" (46.4cm)  
Overall Width: 9.66" (24.6cm)  
Overall Height: 20.75" (52.7cm)

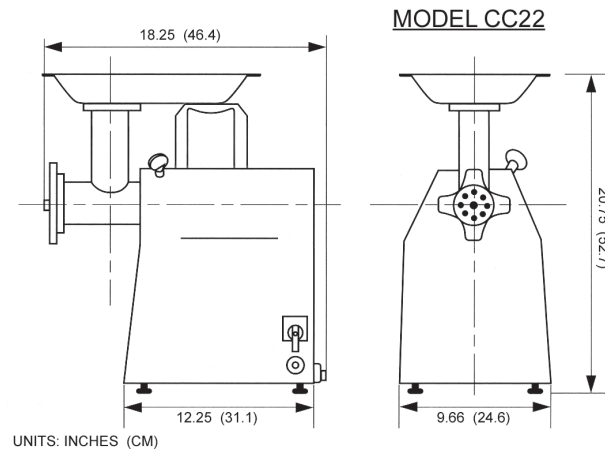
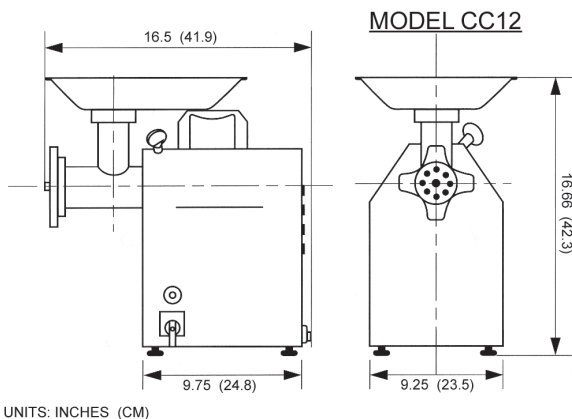

**GLOBE FOOD EQUIPMENT COMPANY**  
www.globeslicers.com

2153 Dryden Rd.  
Dayton, OH 45439  
Phone: 937-299-5493  
Phone: 800-347-5423  
Fax: 937-299-4147

Printed in U.S.A. 3-2009

Specifications are subject to change without notice.