

SELF-CONTAINED DIRECT DRAW DISPENSERS

Perlick Features

- Available in 2, 3 and 4 keg models.
- Front vented compressor.
- Two inch foamed-in-place insulation provides greater energy efficiency and structural strength.
- Quiet, high efficiency refrigeration system.
- Self-closing field reversible doors with locks.
- Heavy-duty polyethylene door sill.
- Stainless steel exterior.
- Heavy-duty stainless steel hinges.
- Heavy-duty reinforced base will not bend or sag.
- Epoxy coated evaporator coil.

MODEL NOS.

- DS60
- DS72
- DS84

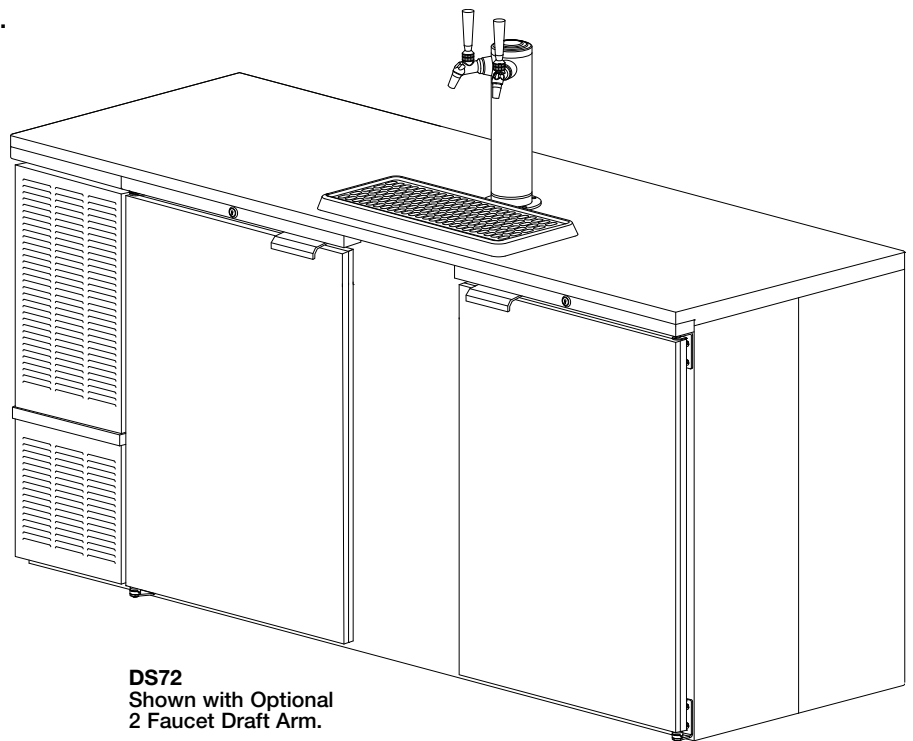

DS72
Shown with Optional
2 Faucet Draft Arm.



8300 West Good Hope Road • Milwaukee, WI 53223 • Phone 414-353-7060 • Fax 414-353-7069
Toll Free 800-558-5592 • E-Mail: Perlick@Perlick.com • www.Perlick.com

Form No. 090905
Rev. 05.25.10

Sizes and Specifications Self-Contained Direct Draw Dispensers

Job _____
 Area _____
 Item No. _____
 Model No. _____

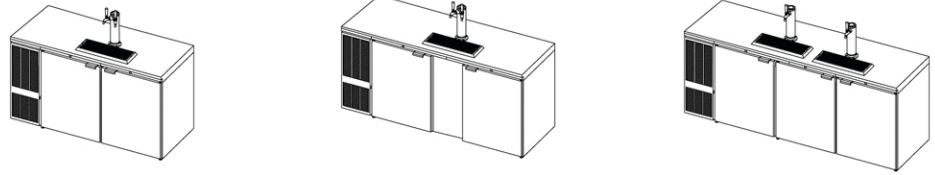

		MODEL NOS.		
DOOR FINISH	Black	DS60B	DS72B	DS84B
	Stainless Steel	DS60S	DS72S	DS84S
CABINET DIMENSIONS	Length - Inches (mm)	60" (1524)	72" (1829)	84" (2134)
	Depth - Inches (mm)	24 ³ / ₄ " (629)	24 ³ / ₄ " (629)	24 ³ / ₄ " (629)
	Height - Inches (mm)	34 ¹ / ₂ " (876)	34 ¹ / ₂ " (876)	34 ¹ / ₂ " (876)
NUMBER OF DOORS		2	2	3
KEG CAPACITY		2 Keg	3 Keg	4 Keg
DISPENSING HEAD		Customer Choice		
CONDENSER UNIT H.P.		1/4	1/3	1/3
RUNNING LOAD - AMPS		5.9	7.5	7.5
SHIP WT Lbs. (kg)		385 (175)	425 (193)	500 (227)
INTERIOR	Door sill: High strength polyethylene. Door pan and ceiling: High strength polystyrene. Floor pan: Stainless steel. Walls: Galvanized steel.			
EXTERIOR	All Models: The top is 20 gauge stainless steel. The back, front and sides are stainless steel. Bottom is 18 gauge galvanized steel. Black Models: Doors and grilles are black vinyl coated steel. Stainless Models: Doors and grilles are stainless steel.			
REFRIGERATION	R-134a capillary tube-type. Aluminum fin and copper tube evaporator, epoxy coated coil. Forced air into dispensing head. Adjustable temperature control. Self-defrosting. Pull-out condensing unit for service and cleaning.			
VENTILATION	Front vented.			
ELECTRICAL	115 Volt, 60 Hz., 1 Phase AC. Furnished with three prong, six foot NEMA5-15P cord. Contact Perlick for other voltage/frequency requirements.			
PLUMBING	3/4" NPT drain exits out right end or 1" NPS out bottom. Evaporator condensate has been plumbed to a condensate pan located in the compressor housing.			
INSULATION	Foamed-in-place polyurethane; 2" walls, 1 ¹ / ₂ " top and floor.			
OPTIONAL ACCESSORIES	<ul style="list-style-type: none"> • Optional dispensing heads • Leg sets • Keg couplers • Caster sets • Shelf kit • Faucet locks 			

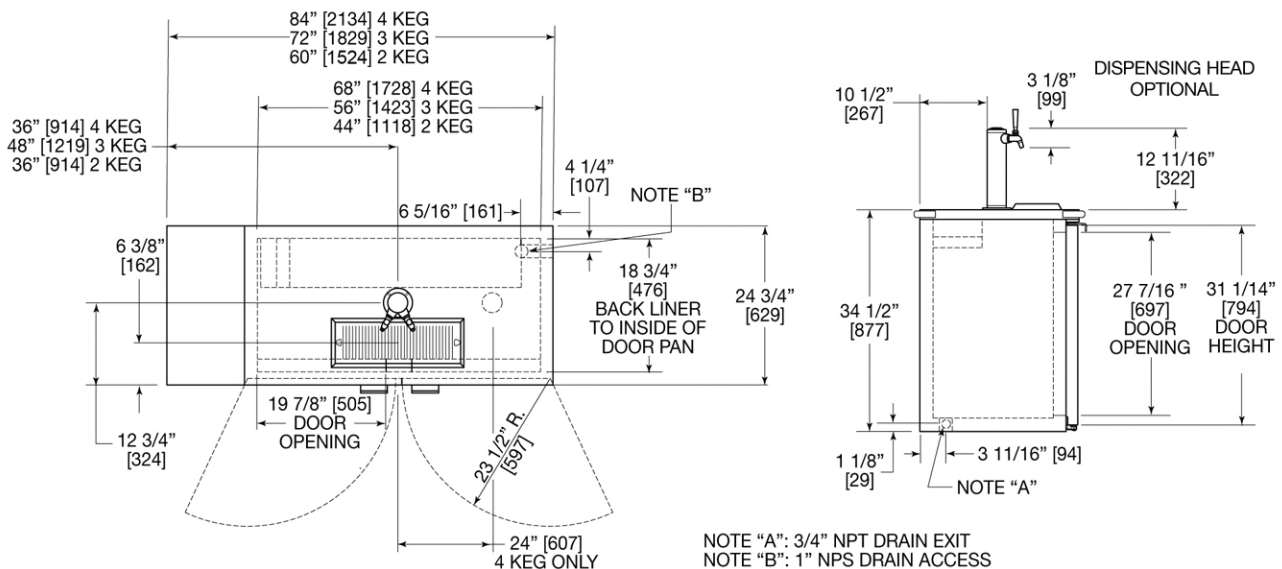

8300 West Good Hope Road • Milwaukee, WI 53223 • Phone 414-353-7060 • Fax 414-353-7069
 Toll Free 800-558-5592 • E-Mail: Perlick@Perlick.com • www.Perlick.com

Perlick is committed to continuous improvement. Therefore, we reserve the right to change specifications without prior notice. Form No. 090905
 Rev. 05.25.10