



N8700-DESP

Drop-In Energy Saving Power (ESP) Hot Food Wells

Project _____
 Item _____
 Quantity _____
 CSI Section 11400
 Approved _____
 Date _____

N8700-DESP: Drop-In Energy Saving Power (ESP) Hot Food Wells

Models

- N8717-DESP ESP hot food well, accommodates one 12" x 20" pan
- N8731-DESP ESP hot food wells, accommodates two 12"x 20" pans
- N8745-DESP ESP hot food wells, accommodates three 12"x 20" pans
- N8759-DESP ESP hot food wells, accommodates four 12"x 20" pans
- N8773-DESP ESP hot food wells, accommodates five 12"x 20" pans
- N8787-DESP ESP hot food wells, accommodates six 12"x 20" pans

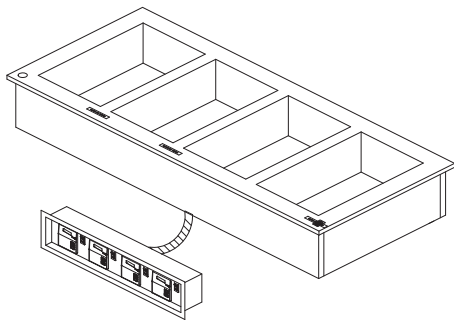

N8759-DESP

Standard Features

- Energy Saving Power wells
- Top is constructed of 18-gauge stainless steel
- Flush mounted die stamped drawn 12" x 20" individual 20-gauge wells
- Wells depressed slightly into the top to hold in condensation
- Standard 1/2" stainless steel drain(s)
- Non-marring press fit top gasket
- Must be hard wired in the field
- Wet and dry operation
- 11.87" x 19.87" single hot food wells are manifolded together standard to one main gate valve
- Unit shall be insulated on the bottom and all sides with 1" of fiberglass
- Individual digital temperature controls standard wired to one main control panel with 4' of conduit and wire. Field install control panel at location
- Energy efficient 500 watt heat-pad per well
- Galvanized exterior body
- One year parts and labor warranty

Options & Accessories

- Fill faucet option
- Autofill option
- 3 phase electrical system*
- Adapter plates and bars
- Single- or double-service flip-up sneezeguards
- 240 volt, 50 cycle electrical system*
- Omit drains and manifold
- Telescoping covers

* Inclusion of this option will alter electrical specifications of the unit

Specifications

Top shall be one-piece 18-gauge stainless steel, with 0.65" (2cm) overhang around perimeter and die-stamped 19.87" x 11.87" (50cm x 30cm) openings with depressed edges. Formed well below each opening shall be 6.25" (16cm) deep. Each well shall be equipped with a 0.5" female N.P.T. drain located in right rear corner. All drains manifold to a 0.5" gate valve at the left. Exterior housing shall be 20-gauge galvanized steel. Unit shall be insulated on sides, bottom and between wells with 1.00" (2.5cm) fiberglass.

Energy Saving Power wells (ESP) provided with individual solid state digital temperature controls wired to one main control panel with 4' of conduit and wire. Each well is individually equipped with a 500 watt heated pad attached to bottom and sides of well. Unit shall have a three-wire electrical junction box to allow hard-wiring at installation. Electrical connections are 208-230V or 240V.



980 S. Isabella Rd.
 Mt. Pleasant, Michigan 48858

Phone: 800-733-8948 or 989-773-7981
 Fax: 800-669-0619

www.delfield.com



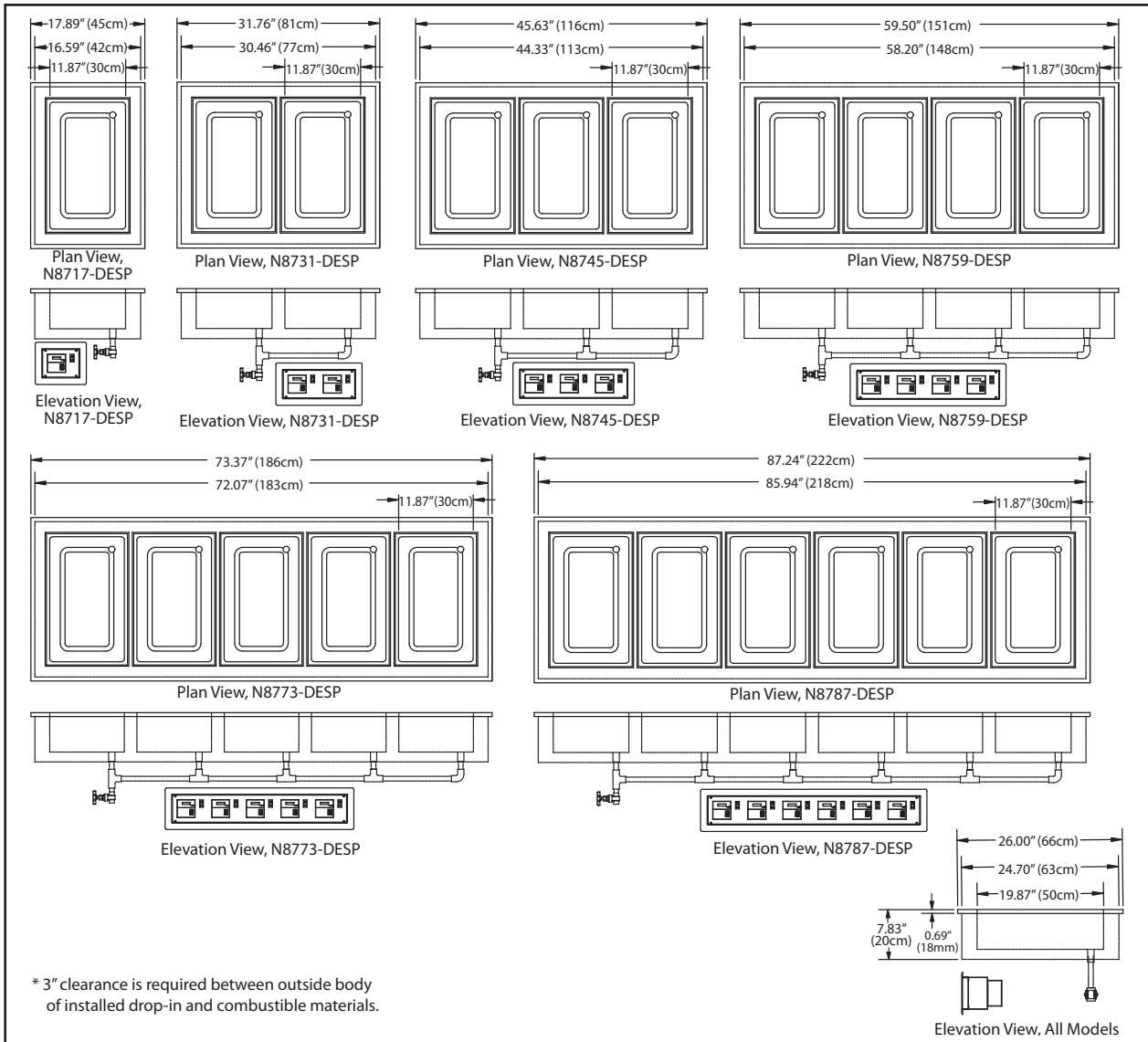

Specifications

Model	Counter Cutout Dimensions	Control Panel Cutout Dimensions	# Of Food Wells	V/Hz/Ph	Watts	Amps	Optional 240V Amps	Ship Weight
N8717-DESP	16.87" X 25.00" (43cm x 64cm)	5.00" x 6.88" x 7.50" (13cm x 17cm x 19cm)	1	208-230/ 60/1	500	2.4/2.7	2.1	41lbs (19kg)
N8731-DESP	30.75" x 25.00" (78cm x 64cm)	5.00" x 11.88" x 7.50" (13cm x 30cm x 19cm)	2	208-230/ 60/1	1000	4.8/5.4	4.2	99lbs (45kg)
N8745-DESP	44.62" x 25.00" (113cm x 64cm)	5.00" x 17.38" x 7.50" (13cm x 44cm x 19cm)	3	208-230/ 60/1	1500	7.2/8.1	6.3	134lbs (61kg)
N8759-DESP	58.50" x 25.00" (149cm x 64cm)	5.00" x 22.88" x 7.50" (13cm x 58cm x 19cm)	4	208-230/ 60/1	2000	9.6/10.8	8.4	166lbs (75kg)
N8773-DESP	72.37" x 25.00" (184cm x 64cm)	5.00" x 28.38" x 7.50" (13cm x 72cm x 19cm)	5	208-230/ 60/1	2500	12.0/13.5	10.5	186lbs (84kg)
N8787-DESP	86.25" x 25.00" (219cm x 64cm)	5.00" x 33.88" x 7.50" (13cm x 86cm x 19cm)	6	208-230/ 60/1	3000	14.4/16.2	12.6	236lbs (107kg)

Delfield reserves the right to make changes to the design or specifications without prior notice.

N8700-DESP

980 S. Isabella Rd.
Mt. Pleasant, Michigan 48858

Phone: 800-733-8948 or 989-773-7981
Fax: 800-669-0619
www.delfield.com

Printed in the U.S.A.
DSN8700D
08/13

