

**Commercial Kitchen Hoods**  
**Installation, Operation, and Maintenance Manual**

---



# **RECEIVING AND INSPECTION**

At time of delivery with driver present and before signing for your goods, check for damage and complete shipment. Damage can be obvious or hidden, it is imperative to confirm that all items are in good condition and all items are accounted for including parts and accessories. Checking for damage may require opening packaging. It is **YOUR** responsibility to inspect each item before signing the Driver's Bill of Lading. **DO NOT SIGN until you have thoroughly inspected all goods on all pallets/in boxes.** If damage is found, record all essential information on the bill of lading in detail as needed. Take pictures of packaging and damaged goods for supporting documentation. If you accept the delivery as received in good condition, you relieve the trucking company and North American Kitchen Solutions, Inc. of all claims for damaged and/or missing products. If you choose to accept the delivery with damage noted on the Bill of Lading it is your responsibility to file a claim with the final carrier.

## **Description of Assemblies**

### **HBOX/HBMUA – Hybrid Box Hood/Hybrid Box Makeup Air**

**Front and Rear of Equal Height, ranging from 18" – 24"**

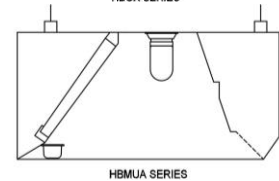
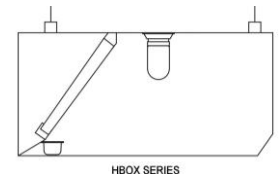

### **LBOX/LBMUA – Low Box Hood/Low Box Makeup Air**

**Front as low as 6", Rear ranging from 18" – 24"**

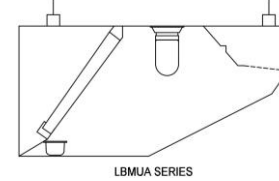
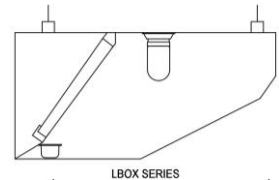

### **T – Tapered Hood**

**Front face 6", Front and Rear of Equal Height, ranging from 18" – 24"**

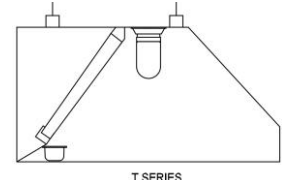

### **BS – Backshelf**

**Front down to 0", Rear 42" Tall**

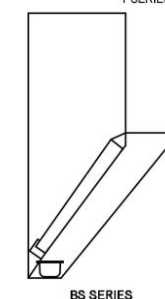

**Save these instructions.** This document is the property of the owner of the equipment. Leave this document with the owner when installation or service is complete.

---

## **WARNING!!**

**Installation of this equipment should only be performed by a qualified professional.**

**Please read this manual thoroughly before installing or servicing this equipment.**

## **LISTINGS**

This hood is UL710 and CAN/ULC S646-10 (Re-affirmed 2016) Listed when installed in accordance with these installation instructions and National Fire Protection Association Standard “NFPA 96, Removal of Smoke and Grease-Laden Vapors from Commercial Cooking Equipment.”

This hood is ANSI/NSF2-2015 Listed for the Standard for Food Equipment, Revised June 2016.

This hood is ANSI/NSF51-2014 Listed for the Standard for Food Equipment Materials, Revised March 2015.

## **INSTALLATION**

The equipment is required to be installed and operated with the designed airflow, filters and construction that are identified and explained within this manual. If there are any questions about any items, please call the service department at **1-800-715-1014** for warranty and technical support issues.

**WARNING: IMPROPER INSTALLATION, ADJUSTMENT, ALTERATION, SERVICE AND/OR MAINTENANCE CAN CAUSE PROPERTY DAMAGE, INJURY OR DEATH.**

**PLEASE READ THE INSTALLATION, OPERATION AND MAINTENANCE INSTRUCTIONS BEFORE INSTALLING OR SERVICING THIS EQUIPMENT.**

## **STORAGE**

If a kitchen hood system must be stored prior to installation it must be protected. Indoor storage is recommended. For outdoor storage, cover the hood and accessories with a tarp to keep it clean, dry, and protected from UV (Ultraviolet) Radiation damage.

Improper storage which results in damage to the unit will void the warranty.

## Site Preparation

1. Make sure that clearance is provided around the installation site to lift the hood into its final position.
2. Locate unit when possible so that the exhaust duct outlet will be in line with the exhaust fan to keep the duct run simple and direct to avoid long runs and excessive turns.
3. Review the project plans and drawings for the job.
4. Determine the exact location of the hood – consult your project plans and drawings. The area should be inspected to verify that there are no interferences which will prevent proper installation.
5. All overhead beams and angles must be of sufficient structural strength to support the weight of the hood. It may be necessary to reinforce the existing structural beams. Refer to the project spec drawing for hood weight(s).
6. Confirm that there is adequate room available to install the hood and all ductwork to provide proper clearances from combustible material.

IMC, NFPA96 and local authorities having jurisdiction may call for a minimum clearance (typically 18 inches for Type 1, grease rated hoods) between the cooking hood(s), exhaust ducts, and building materials which are combustible. However, IMC and NFPA96 do outline acceptable clearance reduction methods which most local jurisdiction authorities will accept along with the clearance reduction methods approved in the manufacturer's UL listing for Type 1, grease rated hoods.

SMACNA Guidelines should be followed when hanging and installing the hood system.

# Combustible Clearance

## Top Combustible Clearance

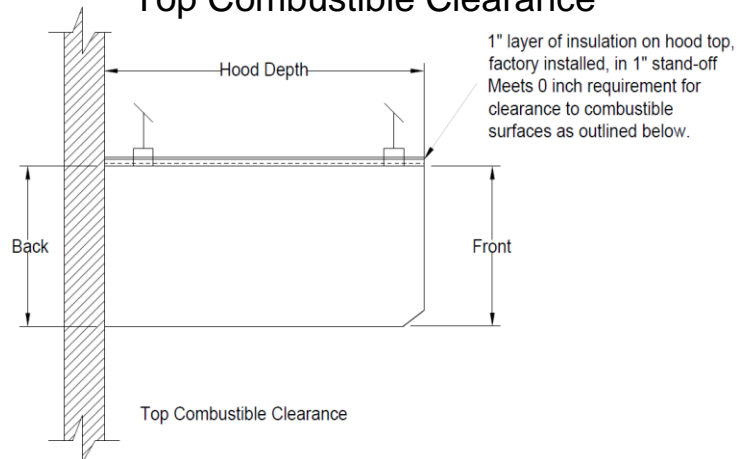

## End Combustible Clearance

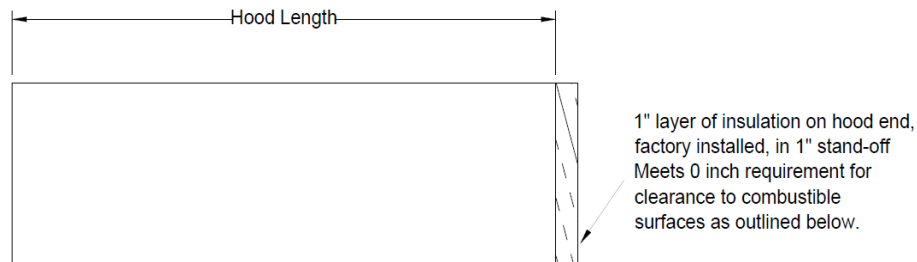

## Front and Rear Combustible Clearance

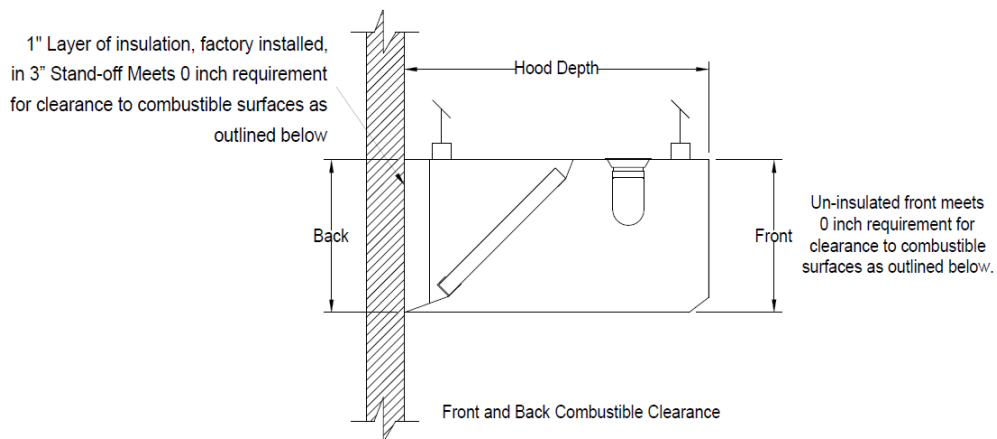

- If the Rear, Top or sides of the hood are insulated, then it may be in contact with a combustible surface. The Front of the hood does not require insulation to be in contact with a combustible surface.
- Hood surfaces which are perpendicular to the insulated surface do not need to be insulated in order to maintain the zero-clearance rating.

## Clearance Reduction Methods:

Clearance reduction methods have been evaluated and tested and are certified by UL. The method of test was derived from UL 710 with temperature criteria taken from appropriate standards.

The hood may be installed with a 0" clearance to combustible materials per UL if constructed in one of the following manners:

- 1" thick min. layer of insulation of type **Johns Manville 90005510, or similar insulation, or listed kitchen exhaust duct insulation.**
- Cooking surface must not exceed temperatures above 600°F.

### Wall or Single Island Canopy Hoods

#### Hood Installation Overview

1. When uncrating the hood please be careful not to bend or scratch the outer surface of the hood. Upon receiving your equipment, check for any interior or exterior damage. When the truck arrives at your location and the shipment is unloaded, it is **YOUR** responsibility to inspect each and every item for damage **BEFORE** signing the driver's delivery receipt/Bill of Lading. **DO NOT sign until you have thoroughly looked over everything.** Once you sign the delivery receipt/Bill of Lading, you relieve the trucking company and North American Kitchen Solutions, Inc. of any and all claims for damaged and/or missing items
2. If the hood is provided with filler panels, shipped loose, install them now.
3. If the hood is provided with hood/duct sensors or thermostats, install them now.
4. If the hood is provided with a back return plenum (BRP) install it now. See page 13, Installing the Back-Return Plenum.
5. If possible, connect ductwork to the hood before hanging or lifting into place, unless it prohibits the hood from being raised into place. For information on ductwork and duct collars, see page 10 and 11.
6. At this point, drill holes in the building structural support system or utilize uni-strut to match up with the hanging bracket holes. Then slowly and evenly raise the hood into position and insert ½" (12.7 mm) diameter threaded rod (provided by others) between the hanger brackets and structure.
7. If the hood was provided with any front or side ceiling supply plenums (other than the back supply plenum), install these now. See page 13 for Installing Front/Side Ceiling Supply Plenums.
8. Install the remainder of both the exhaust and supply ductwork. For further guidelines see page 10 and 11, Installing Ductwork.
9. If the hood is provided with any backwall panels, install them now. See page 18, Installing Backwall

Panels.

10. If the hood is provided with any side skirts, install them now. See page 19, Installing Side Skirts.
11. If the hood is a Type I hood, it will require a fire suppression system. Once the Type I hood(s) and ductwork are fully installed, equipment under hood is in place and walls are complete, the fire system should be completed. If the hood is provided with a factory-installed fire suppression system, a licensed and certified fire system installer should be contacted at this time to complete the final hookups, testing and system certification based upon manufacturer's specification and local fire codes.
12. If the hood is provided with a control package, it will need to be installed and wired by a licensed and certified electrician. This typically includes wiring the hood temperature sensors, hood lights and wiring the fire suppression micro-switches. If applicable, see wiring diagram provided with the control package.
13. If the hood is provided with enclosure panels, install them now. See page 20, Installing Enclosure Panels.
14. Install the rest of the hood accessories provided. This may include grease baffle filters or condensate mesh filters, grease cups, light bulbs (provided by others), light globes, and hem strips.

For Type I hoods, the hood hanging height requirements are listed on the UL label. Typical canopy hood hanging height will be 78" from the finished floor to the bottom of hood.

For questions regarding the supporting structure and its integrity, either the contractor or structural engineer must be consulted.

**WARNING: NEVER PUNCTURE THE HOOD'S GREASE CONTAINMENT AREA TO HANG THE HOOD OR TO HANG ITEMS FROM THE HOOD. PUNCTURING THE GREASE CONTAINMENT AREA WILL VOID THE WARRANTY AND LISTING ON THE HOOD.**

## **Backshelf Hoods**

A Backshelf style hood is designed to be mounted close to the cooking appliance and typically incorporates underhang instead of overhang as utilized with canopy style hoods. The proximity design, in addition to the hanging brackets, may include a back mounting flange.

Therefore, hanging the hood differs slightly from that of a wall canopy or single island canopy hood.

1. Locate the studs in the wall.
2. Drill  $\frac{1}{2}$ " (13 mm) diameter holes in the bottom hood mounting flange. Be sure to align to wall studs.
3. If using hanging brackets, lift the hood and level before installing the lag bolt to secure the hood (fasteners supplied by others).
4. Bolt  $\frac{1}{2}$ " threaded rod into the remaining hanging brackets.
5. Fasten threaded rod to the ceiling supports and/or uni-strut, then level the hood.

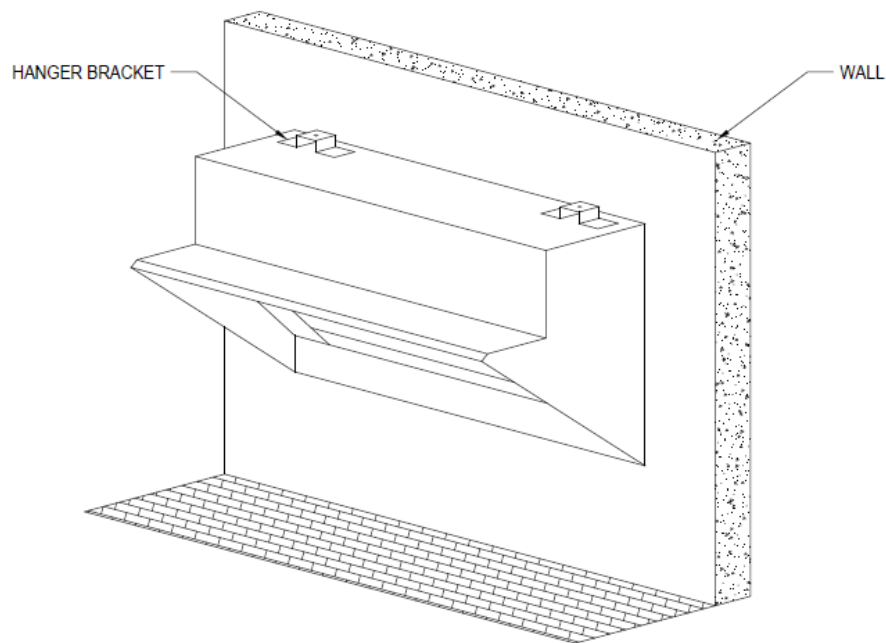

## Filler Panel Installation

1. Uncrate the hood and lay it on the floor with protective material between the hood



and the floor.

2. Position the filler panels to the back of the hood, and tack weld them into place.
3. To allow for ease of cleaning, caulk the external seams with NSF Approved silicone caulk. Caulk provided by others.

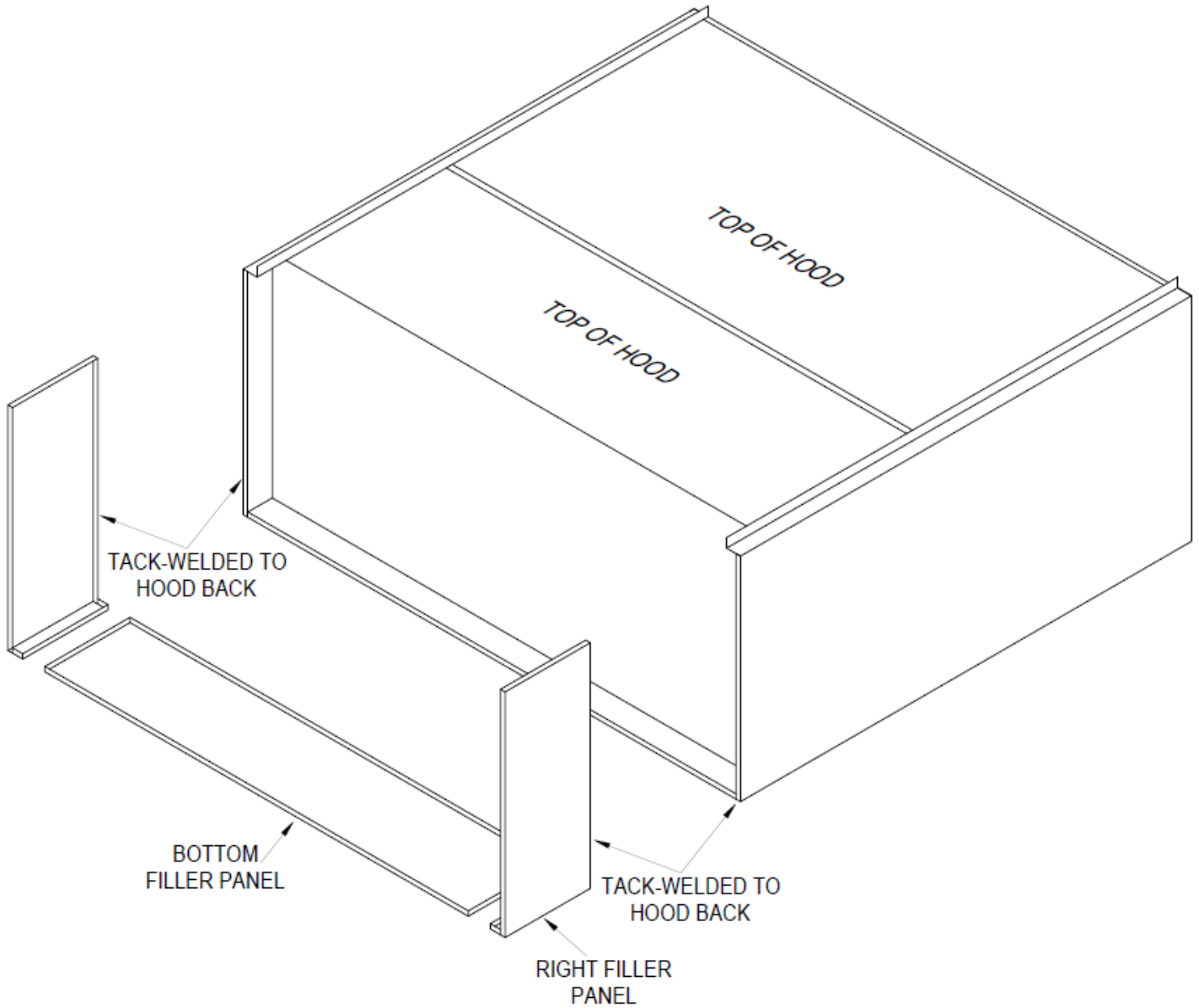

## Duct Collar Installation

### Exhaust Ducts

1. The exhaust duct connection needs to be located within shaded area as shown.
2. The exhaust duct connection is to be a continuous liquid-tight weld. Weld with a non-ferrous filler wire, such as silicon bronze or stainless-steel filler wire.

All stainless-steel areas are to be protected from weld splatter.

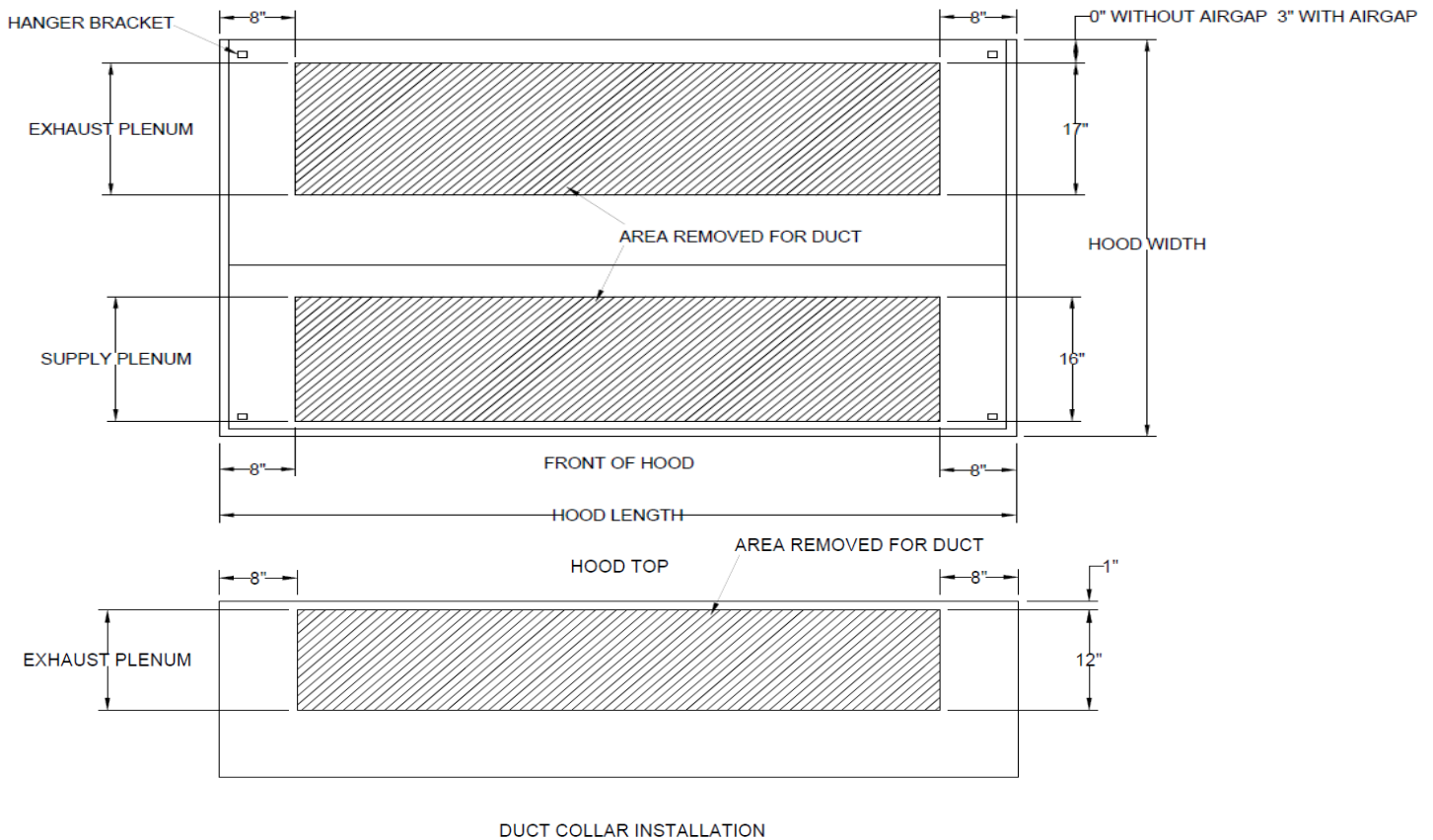

**ATTENTION:**

One (1) Exhaust Duct Connection to be located every 10'-0"

One (1) Supply Duct collar to be located every 7'-0"

**Ductwork**

Exhaust - As specified in NFPA 96, Ch. 7.5 (latest edition), exhaust duct systems must be constructed in the following manner:

Materials: Ducts shall be constructed of and supported by carbon steel not less than 1.37 mm (0.054") (No. 16 MSG) in thickness, or stainless steel not less than 1.09 mm (0.043") (No. 18 MSG) in thickness, UL listed Factory Made.

Installation: All seams, joints, penetrations, and duct to hood collar connections shall have a liquid-tight external weld. If you have an automatic fire damper, please refer to that manual for installation instructions now.

Supply - Supply ductwork (where applicable) should be connected to the hood in a manner approved by the local code authorities. If using prefabricated banded duct work, please refer to manufacturer's installation guide. It is recommended that a licensed HVAC installer or General Contractor completes the hood and ductwork installation.

### **Internal Perforated Supply (IPS) Screen Removal**

**Tools needed – 5/16” Nut Driver and proper Gloves to protect against metal edges**

1. Use 5/16” nut driver to remove #8 hex head screws from IPS.

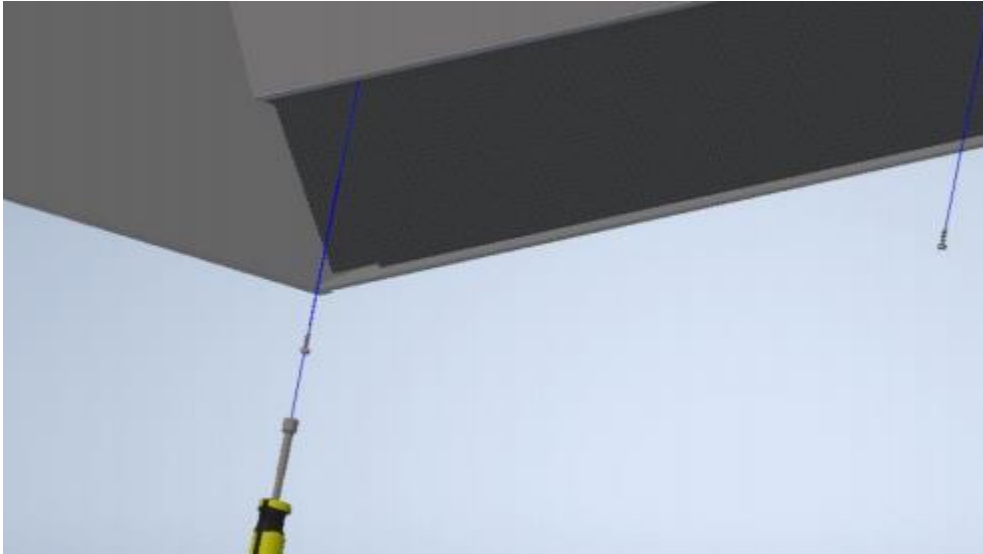

2. Rotate IPS down by pulling on trim strip where indicated (be cautious to avoid damage to hood and IPS)

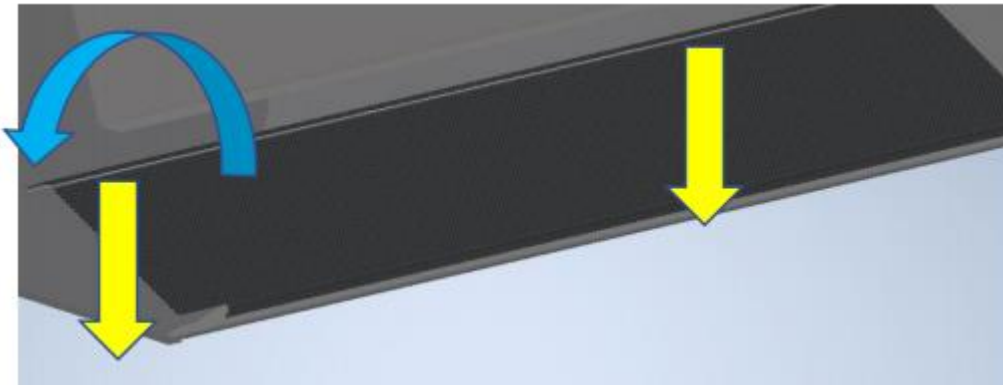

IPS Screen removal Continued

3. Push up on IPS where indicated to remove from front hem

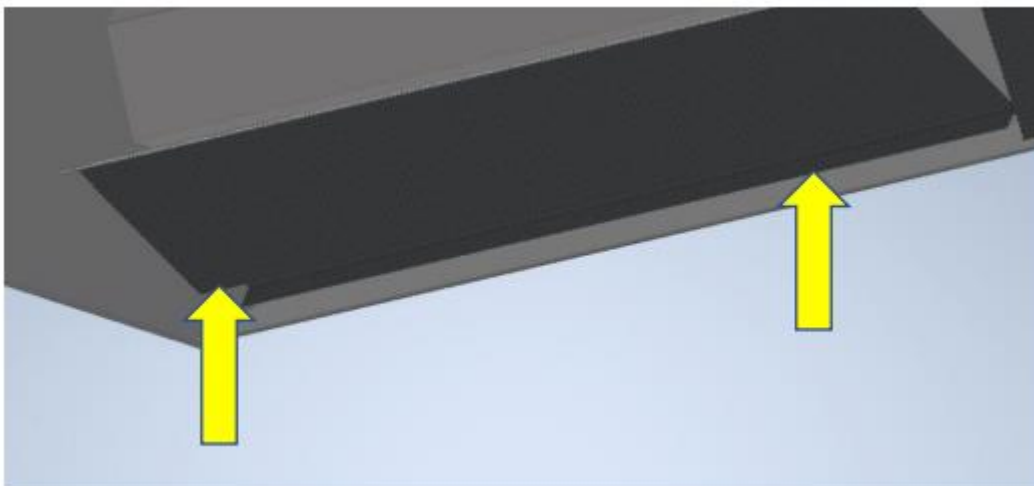

4. IPS is now free to be removed. Repeat if IPS is in two (2) pieces

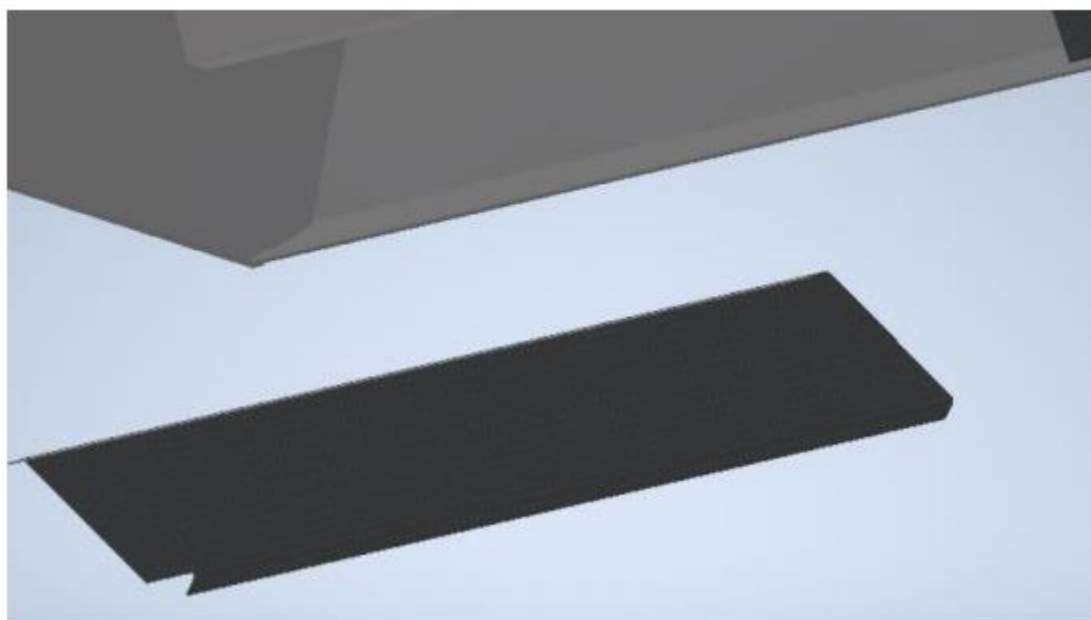

Installation is reverse of removal

## Installing the Back Return Plenum

## Supply Ducts

1. Find the center of the back return plenum.
2. If the back return plenum is to have one opening, cut the opening such that it is centered.
3. The supply duct connection is tack-welded at 1" to 2" intervals or sheet metal screws at 3" to 6" spacing to the hood.
4. When the back return plenums are insulated, the edges of the insulation must be taped after the hole is cut. (The insulation tape is provided by others).

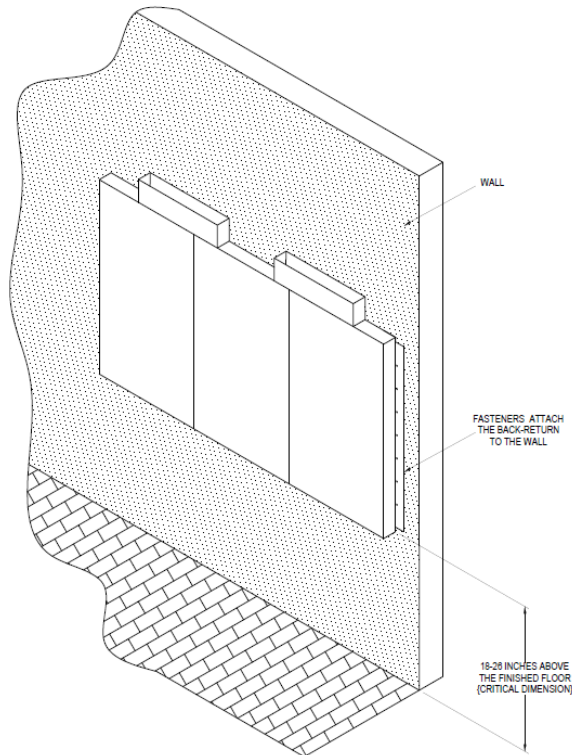

## Hanging the Plenum

5. The back return plenum needs to be mounted 18" to 26" above the finished floor. This is measured from the lowest rear edge of the back supply plenum to the finished floor.
6. Fasten the back of the plenum to the wall, going through the lower portion of the plenum back supply wall.
  - a. These fasteners supplied by others are to help maintain the location of the back supply and are intended to hold the weight of the back supply unit.
  - b. The fasteners should not interfere with the air diffusers.

## Installing Front and Side Plenum

### Hanger Bracket and Threaded Rod Installation

1. Insert  $\frac{1}{2}$ : (12.7 mm) diameter threaded rod (supplied by others) into hanger brackets on the ceiling supply plenum top. Raise and hang the ceiling supply plenum from adequate roof or ceiling supports.
2. The ceiling supply plenum should be resting lightly against the hood. The hood is only used to position the plenum; it is not intended to support the plenum. All hanger brackets on the ceiling supply plenum must be used and the plenum must be properly supported while lifting to prevent damage or distortion. The ceiling supply plenum must be level to operate properly.
3. It is recommended that caulk be applied at the mating seams and surfaces of the ceiling supply plenum, the hood, and the wall. If the ceiling supply plenum is next to a wall, you will need to caulk around the surface next to the wall. Caulk the joints with NSF Approved silicone caulk. Caulk is provided by others.

### Uni-Strut Installation

The uni-strut (supplied by others) supporting the hood may be cantilevered over the end of the hood. Utilizing the ceiling supply plenum's hanger brackets, securely fasten to the uni-strut.

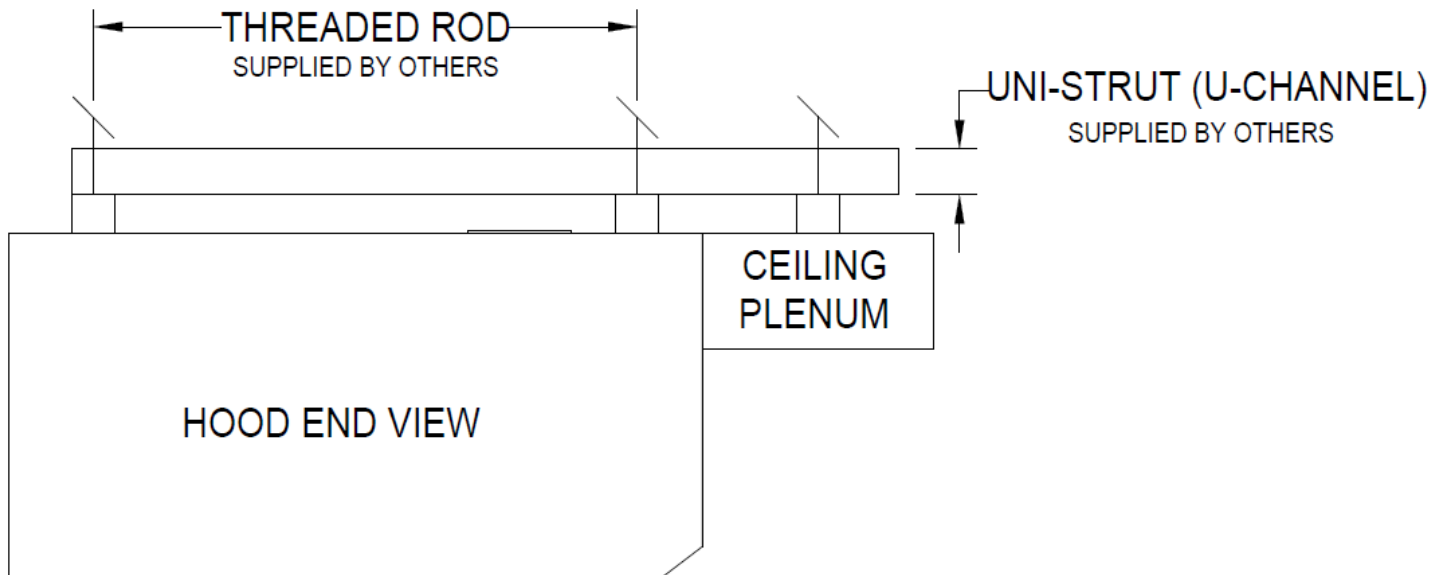

## Perforated Supply Plenum (PSP) Screen Removal

Tools needed – 5/16” Nut Driver and proper Gloves to protect against metal edges

1. Use 5/16” nut driver to remove #8 hex head screws from PSP Screen.

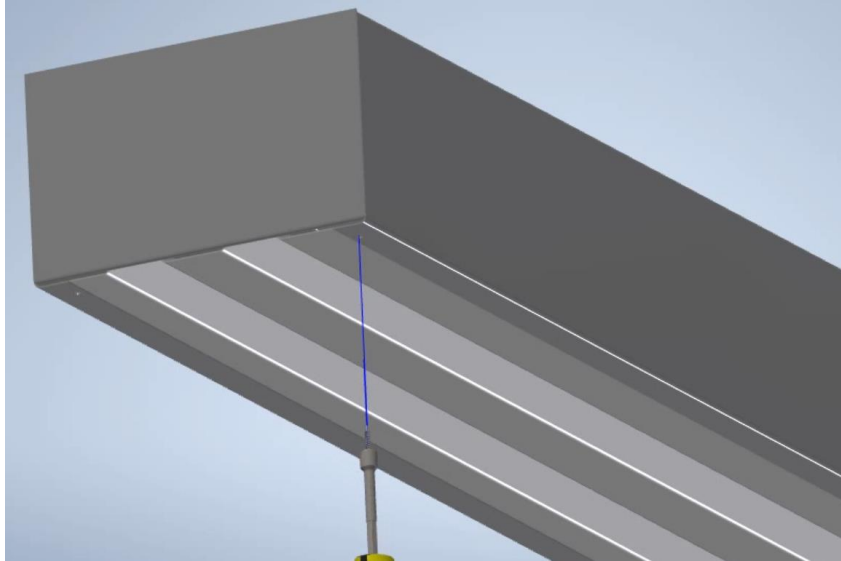

2. Push the screen away from the screw location to 'unlock' the screen.

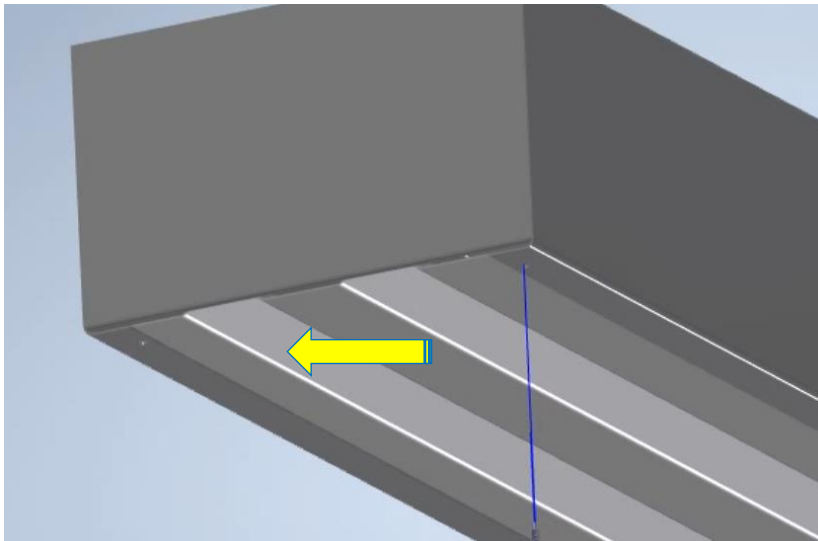

## PSP Screen removal Continued

3. Push up on PSP Screen and this will allow it to drop out easily (be cautious to avoid damage to PSP and Screen).

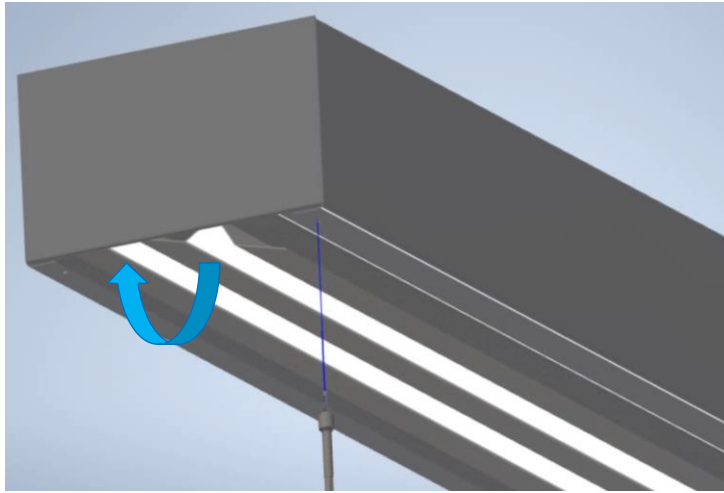

4. PSP Screen is now free to be removed. Repeat if PSP Screen is in two (2) pieces.

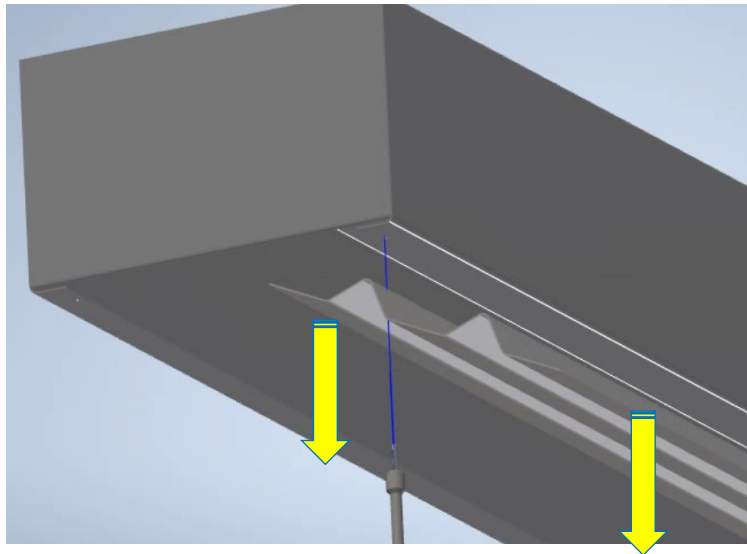

Installation is reverse of removal.



## Electrical Connections

### Hood Lights

If the hood is provided with lights, a junction box will be located on top of the hood for field connections. Use minimum 14 AWG copper wire. Light bulbs will not be provided. For incandescent fixtures, standard light bulbs up to 100 watts may be used.

For multiple hood systems that have more than 14 lights total, the hood lights must be wired to multiple circuits. Each circuit must have less than 14 lights total.

### Hood Light and Fan Switches

For hood systems provided with hood light and fan switches, a junction box will be located on top of the hood for field connections and must be connected in the field between the junction box and light switches. Use minimum 14 AWG copper wire for all 120 VAC field connections. Standard switches will be rated for 15 amps.

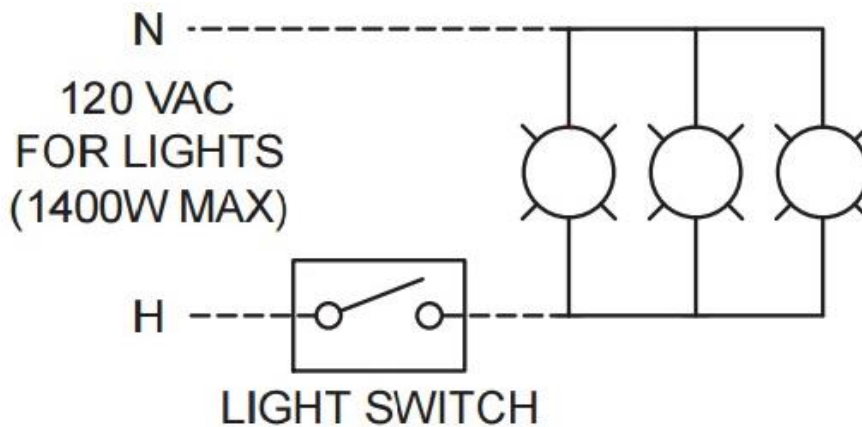

## Installing Backwall Panel

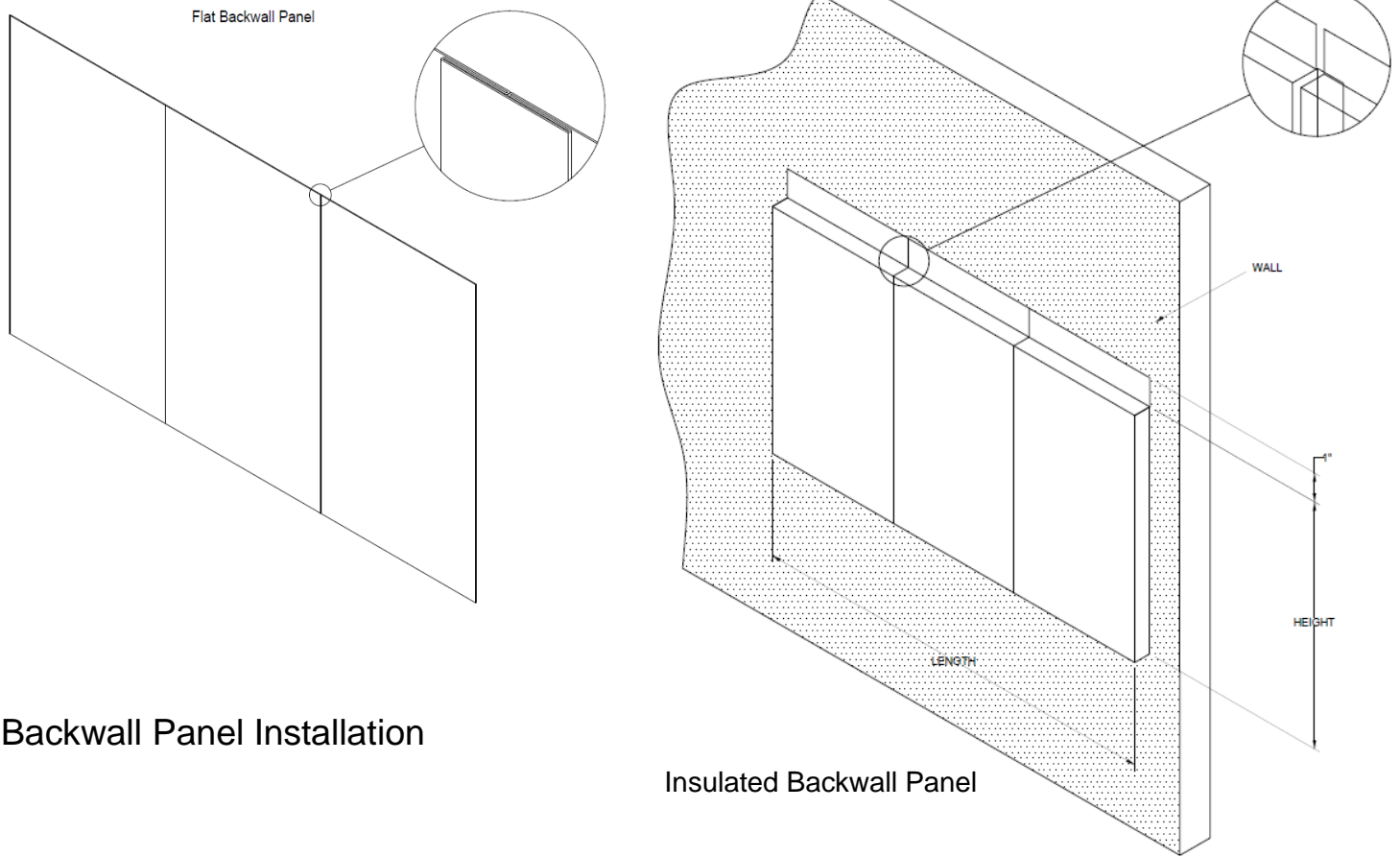

## Backwall Panel Installation

1. After hood is hung into position, slide the top of the backwall panel behind the back of the hood. If the hood is provided with flat backwall panels, seam strips will be provided. Install seam strips between panels as shown in the flat backsplash panel section view.
2. After the backwall panel and seam strips have been positioned, drill holes in the panel and fasten to the wall.
3. Caulk the joints between the hood and the backsplash panel with NSF Approved silicone caulk. Caulk provided by others.

## Installing Side Curtain

1. After the hood is hung in position, line up the top of each side curtain with the side of the hood.
2. Adjust side curtain to line up with back of the hood.
3. Install trim strip where the side curtain meets the side of the hood.
4. Caulk the joints between the hood and the side curtain with NSF Approved silicone caulk. Caulk provided by others.

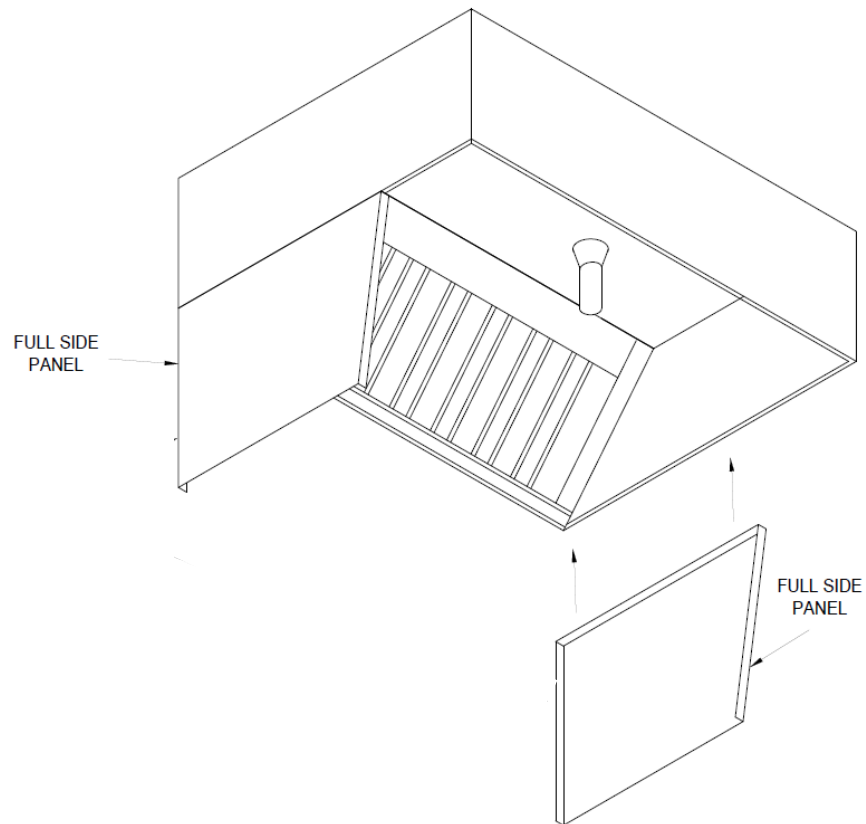

## Installing Ceiling Enclosure Panels

Prior to the installation of Ceiling Enclosure Panels, be sure that all ductwork, fire and electrical connections have been made.

1. Position the end enclosure panels on the hood, and clamp into place clamps provided by others and then tack-weld the panels into place.
2. Fasten the end enclosure panels to the wall (Fasteners provided by others).
  - a. If the hoods are mounted back-to-back (Island type), panels to be bolted to each other (Fasteners provided by others).
3. Fasten enclosure panels.
4. To allow for ease of cleaning, caulk the external seams with NSF Approved silicone caulk. The caulk is not provided.

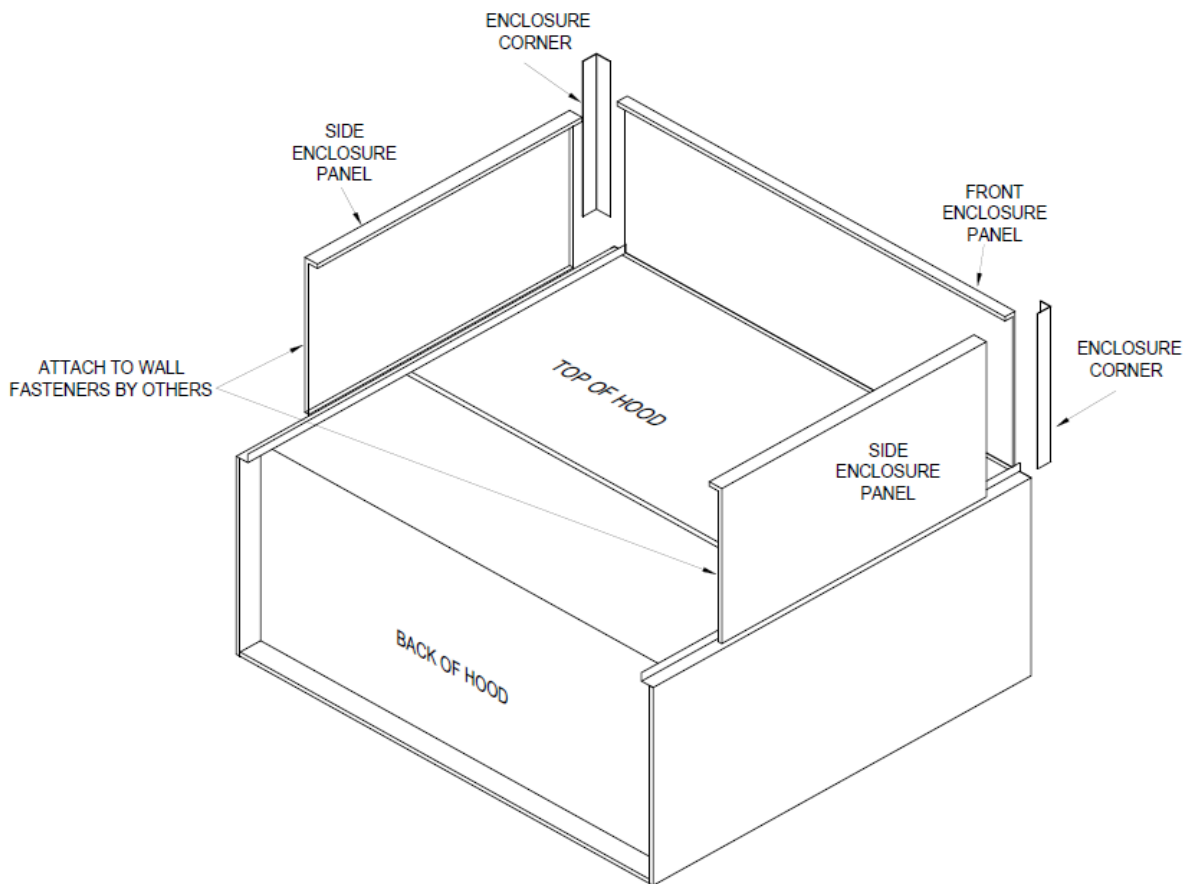

CEILING CLOSURE INSTALLATION

## Operation

Prior to starting up units, the following items must be verified:

1. Both Exhaust and Supply fans must be wired correctly and rotation must be verified. Direction can be confirmed by observation of the arrows stamped on them.
2. All filters must be in place with no gaps.
3. All Equipment located under the hood is in place and functioning.
4. HVAC systems are in place and operating as per manufacturer's recommendations.

Commercial kitchen ventilation hoods are intended to be used with ductwork and fans which have been properly sized and properly installed in accordance with manufacturer's specifications and local code requirements. NOTE: Use of a Licensed HVAC or General Contractor is recommended.

Before turning on cooking equipment, confirm that the makeup air and exhaust fans are on. Leave fans on for at least 30 minutes after cooking equipment is shut off.

Clean hood as needed to comply with local code requirements and as directed in the Maintenance section of this manual.

### **Guidelines before Start-up**

When referencing the airflow rates in UL file, please note:

- a) The exhaust and supply (when provided) air flow rates were established under controlled laboratory conditions
- b) Greater exhaust and/or lesser supply air (when provided) is required for complete vapor and smoke removal in specific installations.

Performing a test and balance of a system is needed to ensure proper and efficient operation of the system. Whenever there is effluent and hot air removed, a large amount of air must be replaced to balance the space. Any change in the pressure differential between inside and outside air will affect the operation of a system.

## **Guidelines before Start-up (continued)**

A test and balance report, as well as the simple performance test in International Mechanical Code Section 507.16.1, should be included in all jobs; code inspectors are increasingly enforcing these requirements. Requirements in the 2006 IMC, which is currently effective in most parts of the United States, are as follows:

*“507.16 Performance test. A performance test shall be conducted upon completion and before final approval of the installation of a ventilation system serving commercial cooking appliances. The test shall verify the rate of exhaust airflow required by Section 507.13, makeup airflow required by Section 508, and proper operation as specified in this chapter. The permit holder shall furnish the necessary test equipment and devices required to perform the tests.*

*507.16.1 Capture and containment test. The permit holder shall verify capture and containment performance of the exhaust system. This field test shall be conducted with all appliances under the hood at operating temperatures, with all sources of outdoor air providing makeup air for the hood operating and with all sources of recirculated air providing conditioning for the space in which the hood is operating. Capture and containment shall be verified visually by observing smoke or steam produced by actual or simulated cooking, such as with smoke candles, smoke puffers, etc.”*

## Troubleshooting Guide

Problem: Smoke blows away before reaching the bottom of the hood.	
Are there pass-thru windows near the hood?	Adjust amount and locations of makeup air to eliminate drafts through the pass-thru windows.
Is the makeup air part of the hood or an attached plenum?	Try turning off or reducing the amount of makeup air; block off portions of the supply to direct air away from the problem area (test with cardboard).

Problem: Pilot lights are being blown out or cooking equipment is being cooled by make-up air.	
Are there drafts from makeup air?	Try turning off or reducing the amount of makeup air; block off portions of the supply to direct air away from the problem area (test with cardboard first); remove any obstructions in front of supply that directs air toward cooking equipment.

Problem: Cold air can be felt by the cook at the hood.	
Is this a short circuit hood?	Turn off or reduce the amount of air supplied to short circuit.
Is the makeup air part of the hood or an attached plenum?	Try turning off or reducing the amount of makeup air; cool the supply air

Problem: Cooking odors in the dining area.	
Is the hood capturing?	Hood is not drawing enough air, see sections above on hood capture.
Is there a draft through doors between the kitchen and dining area?	Decrease makeup air in the kitchen; increase exhaust air through hood

<b>Problem: Grease is running off the hood.</b>	
Is there grease on top of the hood?	Exhaust duct is not correctly welded.
Is the caulk missing or damaged?	Clean problem area and re-caulk.
Is the grease cup inserted properly?	Put grease cup back in place.

<b>Problem: Hood is noisy.</b>	
Is the fan running in the correct direction?	See fan manufacturer's troubleshooting section.
Are the filters in place?	Replace missing filters.
Is the hood over exhausting?	Slow down fan (see fan troubleshooting section)



## Items which may affect Hood Performance

1. HVAC units are to supply outside air (OA) to the room to balance the system. If HVAC units are not supplying the proper amount of OA to the building, then negative pressure will exist, and the HVAC unit's economizers must be adjusted.
2. HVAC return grilles located very close to a hood can cause performance problems. The return grille competes with the hood to capture air in the room. If a return air grille is located within six feet (6') of the hood, it can have a serious effect on the hood's ability to capture.
3. HVAC diffusers located very close to a hood also can affect the capture ability of the hood. When the air from the HVAC diffuser deflects off the front of the hood, or along the hood, the air flow created can draw smoke and contaminants out of the hood.

Before calling your representative to report a problem, have the following information available:

1. Review / summary of troubleshooting section on (page 20) installation operation manual.
2. Hood model and serial number.
3. Current cooking equipment line-up.
4. Size of hood (length, width, and height).
5. Island or wall configuration.
6. Quantity of hoods on one fan.
7. Nature of spillage (one end; all around the edges).
8. Does the smoke make it to the hood?
9. Height hood is mounted above finished floor.
10. How makeup air is brought into the kitchen (hood, ceiling diffusers, separate plenum).
11. Is the hood system controlled by an automated system or VFD?
12. Is the fan making any unusual noise?

## **RECOMMENDED GUIDELINES FOR MAINTAINING YOUR HOOD SYSTEM**

According to NFPA, dirty hoods are the major cause of fire in commercial kitchens. Following these simple recommended guidelines can prevent that from happening.

### **Hood – Daily** (Recommended)

- Inspect grease filters checking for accumulated grease, clean if necessary (instructions stated below).
- Remove grease cup, empty contents and clean using mild detergent or degreaser if necessary.
- Wipe interior of hood to remove accumulated grease and debris using mild detergent if necessary. Do not use abrasive cleaners such as powdered cleaners, or abrasive cleaning cloths.
- Wipe globes on lights.

### **Hood – Weekly** (Recommended)

- Remove baffle grease filters and wash in dishwasher or sink with mild detergent.  
If application is in a heavy grease-producing environment, more frequent cleaning may be required.
- Clean entire interior of the hood prior to replacing baffle filters. Use mild detergent if necessary; do not use abrasive cleaners or cloths.

We suggest having a certified hood cleaning company inspect and professionally clean your hood system. Below are the recommended guidelines based on use.

- Hoods over non-grease applications/low volume cooking – **1-year cleaning requirement**
- Pizza restaurants and oven hoods – **180-day cleaning requirement**
- Typical restaurants, cafeterias and hotel or hospital kitchens – **90-day requirement**
- Hamburger and fast food restaurants, wood-burning or charcoal-burning stoves, restaurants open 24 hours – **30-day cleaning requirement**

#### **Exhaust Fan – Monthly (Recommended)**

- If belt drive system, check condition of drive belts for proper tension. Adjust belt tension if necessary, as belts tend to stretch during break in period.
- Check belts for fraying and wear, replace when necessary.
- Clean exhaust fan wheel and inside of fan housing. Heavy grease build up can be a fire hazard and can also cause exhaust wheel to become unbalanced, a condition that will result in premature bearing wear.

## TERMS AND CONDITIONS OF SALE

THESE TERMS AND CONDITIONS OF SALE (“*TERMS*”) CONTAIN VERY IMPORTANT INFORMATION REGARDING YOUR PURCHASE, AS WELL AS CONDITIONS, LIMITATIONS, AND EXCLUSIONS THAT APPLY TO YOU AND YOUR PURCHASE. PLEASE READ THEM CAREFULLY. YOUR PURCHASE IS EXPRESSLY LIMITED TO AND MADE CONDITIONAL UPON THE EXCLUSIVITY OF THESE TERMS. ANY PROPOSAL FOR DIFFERENT TERMS OR ANY ATTEMPT TO VARY, IN ANY DEGREE, ANY OF THESE TERMS IS EXPRESSLY REJECTED.

1. **Acceptance.** These Terms govern any purchase made from North American Kitchen Solutions, Inc. (“*North American Kitchen Solutions*”). These Terms, the Manual in which they are contained, installation and maintenance instructions, the applicable invoice, and any documents incorporated or referred to herein or therein, including any future paper or electronic releases issued by North American Kitchen Solutions, constitute the “Order.” The Order is the entire contract between you, the buyer, and North American Kitchen Solutions, the seller, for products purchased from North American Kitchen Solutions. These Terms apply to the Order unless expressly modified or waived in writing by an officer of North American Kitchen Solutions. An Order may only be cancelled by you upon payment of reasonable cancellation charges for expenses incurred or commitments made by North American Kitchen Solutions. Captions in these Terms are for convenience only.

2. **Pricing.** The price for North American Kitchen Solutions’ goods, material, equipment, or items (“*Products*”) is complete, and no deductions, credits, or offsets may be made without North American Kitchen Solutions’ express written consent. Prices are subject to change and surcharges in the event of cost increases in materials and transportation. All complete component accessory material manufactured by others and furnished with Products such as motors, drives, vibration equipment, controls, or other completely assembled component structures, are subject to adjustment to the price at time of shipment regardless of the date of original order entry.

3. **Sales and Similar Taxes.** North American Kitchen Solutions’ prices do not include sales, use, excise, or similar taxes. Present or future sales, use, excise, or other similar tax applicable to the sale of Products shall be paid you, unless an acceptable tax exemption certificate is provided to North American Kitchen Solutions.

4. **Payment.** North American Kitchen Solutions reserves the right to require full or partial payment in advance of any order. Pro-rata payments are due as shipments are made. Each shipment or delivery shall constitute a separate sale, and the default of any shipment or delivery shall constitute a separate sale, and the default of any shipment or delivery shall not vitiate the contract as to other shipments or deliveries.

5. **Return Policy – ALL SALES ARE FINAL.** Because we custom manufacture our hoods to each customer’s specifications, ALL SALES ARE FINAL. We may accept the return of non-custom goods at our discretion, but a restocking fee of 30% will apply and all shipping costs are the responsibility of the purchaser or end user. No merchandise may be returned without a Return Goods Authorization (RGA). Items returned for warranty replacement or exchange will not be eligible for credit if not received within 14 days of the issuance of a Return Goods Authorization.

6. **Free Shipping.** Free shipping offers are limited to standard shipping to the 48 contiguous United States.

5. **Delivery.** Shipping and delivery dates are estimates only. No delay in delivery will subject North American Kitchen Solutions to any costs, damages or fees for late delivery. Delivery of Products is made F.O.B. point of shipment, unless otherwise stated. North American Kitchen Solutions shall not be liable for

delay due to causes beyond its reasonable control (i.e., force majeure events). In the event of such a delay, the date of delivery shall be extended for a period equal to the time lost by reason of the delay.

6. **Changes.** North American Kitchen Solutions may make changes, including improvements and additions, in the technical requirements, specifications, designs, materials, packaging, and place of delivery, method of transportation, quantities, or delivery schedules of the Products by notifying you.

7. **Safety.** The Products may be designed to serve multiple applications. North American Kitchen Solutions offers a range of safety equipment, including guards and other devices, as may be required to meet customer specifications. Without exception, North American Kitchen Solutions recommends that all orders include applicable safety devices. Use of Products ordered without applicable safety devices are your sole responsibility. You warrant that you have determined and acquired any and all safety devices required for the Products. Weather covers and guards for motor and V-belt drives, couplings, shafts and bearings, along with inlet and outlet screens, are optional accessories noted in the price list.

8. **Title.** Title and right of possession of Products remains with North American Kitchen Solutions until all payments (including deferred payments whether evidenced by notes or otherwise) shall have been received to the satisfaction of North American Kitchen Solutions and you agree to do all acts necessary to perfect and maintain such title and right in North American Kitchen Solutions and not to subject any Products to any liens or encumbrances until such payment is made in full.

9. **Governing Law.** This Order shall be governed by and construed according to the laws of the State of Ohio (excluding the conflict of law provisions thereof). At North American Kitchen Solutions' discretion, any action relating directly or indirectly to the Order shall be brought exclusively in the Common Pleas Court of Cuyahoga County, Ohio or the United States District Court for the Northern District of Ohio, Eastern Division, and you irrevocably waive any objection to the jurisdiction of, or venue in, either of these courts and agree that the acceptance of the Order constitutes doing business in the State of Ohio.

12. **Compliance with Law.** You shall comply with all applicable laws, regulations and ordinances related to the Products, and you shall maintain in effect all the licenses, permissions, authorizations, consents and permits that you need with respect to the receipt, use and operation of the Products.

13. **Force Majeure.** NAKS shall not be liable or responsible to you, nor be deemed to have defaulted or breached these Terms, for any failure or delay in fulfilling or performing any terms herein, when and to the extent such failure or delay is caused by or results from acts or circumstances beyond the reasonable control of NAKS including, without limitation, acts of God, flood, fire, earthquake, explosion, governmental actions, war, invasion or hostilities (whether war is declared or not), terrorist threats or acts, riot, or other civil unrest, national emergency, revolution, insurrection, outbreak of disease, lockouts, strikes or other labor disputes (whether or not relating to either party's workforce), or restraints or delays affecting carriers or inability or delay in obtaining supplies of adequate or suitable materials, materials or telecommunication breakdown or power outage.

14. **Waiver.** No waiver by any party of any of the provisions hereof shall be effective unless explicitly set forth in writing and signed by the party so waiving. No failure to exercise, or delay in exercising, any right, remedy, power, or privilege arising from this Agreement shall operate or be construed as a waiver thereof; nor shall any single or partial exercise of any right, remedy, power, or privilege hereunder preclude any other or further exercise thereof or the exercise of any other right, remedy, power, or privilege.

10. **Arbitration.** At North American Kitchen Solutions' discretion, any dispute arising under or in connection with any Order may be submitted to binding arbitration administered by the American Arbitration Association under its Commercial Arbitration Rules, and judgment on the award rendered by the arbitrator may be entered in any court having jurisdiction thereof. The dispute shall be resolved by one neutral arbitrator who shall have no affiliation with either you as the buyer or with North American Kitchen Solutions and shall be selected by the American Arbitration Association office, and held in, Cleveland, Ohio.

**WARNING.** North American Kitchen Solutions' Products are designed and manufactured to provide reliable performance but they are not guaranteed to be 100% free of defects. Even reliable products will experience occasional failures and this possibility should be recognized by the buyer and all end users. If Products are used in life support ventilation systems where failure could result in loss or injury, the buyer and all end users should provide adequate back-up ventilation, supplementary natural ventilation or failure alarm system, or acknowledge willingness to accept the risk of such loss or injury. **DO NOT USE IN HAZARDOUS ENVIRONMENTS** where a fan's electrical system could provide ignition to combustible or flammable materials unless unit is specifically built for hazardous environments. Comply with all local and national safety codes including the National Electrical Code (NEC) and National Fire Protection Act (NFPA).

**CAUTION.** Guards must be installed when fan is within reach of personnel or within eight (8) feet (2.5 m) of working level or when deemed advisable for safety.

**DISCLAIMER.** North American Kitchen Solutions has made a diligent effort to illustrate and describe the Products accurately in all materials; however, such illustrations and descriptions are for the sole purpose of identification and do not express or imply any warranty.

#### **LIMITED WARRANTY**

**WARRANTY AND DISCLAIMER.** This limited warranty extends to you the original purchaser only with proof of purchase. North American Kitchen Solutions warrants that Products shall be free from original defects in workmanship and materials for one year from date of shipment (except for the warranty periods noted for products listed below), provided the Products have been properly handled, stored, installed, serviced, maintained and operated. This warranty shall not apply to Products which have been altered or repaired without North American Kitchen Solutions' express authorization, or altered or repaired in any way so as, in North American Kitchen Solutions' judgment, to affect performance or reliability, nor which have been improperly installed or subjected to misuse, negligence, or accident, or incorrectly used in combination with other substances. You assume all risks and liability for results of use of all Products.

Evaporative cooling pads are warranted to be free of defects in materials and workmanship for a period of one year from date of shipment provided same have been properly handled, stored, installed, serviced, maintained and operated; and further, not subjected to excessive heat, corrosive agents or chemicals, or mechanical abuse that may cause tearing, crushing or undue deterioration, nor used on a system or in a manner other than that for which it was designed as explained in the Order.

**LIMITATION OF REMEDY AND DAMAGES.** All claims under this warranty must be made in writing and delivered by U.S. Mail to:

North American Kitchen Solutions, Inc.  
172 Reaser Court  
Elyria, OH 44035  
Attn: WARRANTY CLAIMS DEPARTMENT

All Product claims must be made within 15 days after discovery of the defect and prior to the expiration of one year from the date of shipment. Claims made beyond that period are barred. Within 30 days after receipt of a timely claim, North American Kitchen Solutions shall have the option either to inspect the

Product at its location or request its return to North American Kitchen Solutions at your expense. North American Kitchen Solutions shall replace, or at its option repair, free of charge, any Product it determines to be defective, and it shall ship the repaired or replacement product to you F.O.B. point of shipment; provided, however, if in North American Kitchen Solutions' judgment circumstances are such to prohibit repair or replacement to remedy the warranted defects, your sole and exclusive remedy shall be a refund of any part of the invoice price, paid to North American Kitchen Solutions, for the defective Product or part.

North American Kitchen Solutions is not responsible for the cost of removal of the defective Product or part, damages due to removal, or any expenses incurred in shipping the Product, or the installation of the repaired or replaced Product or part.

The warranties set forth above do not apply to any components, accessories, parts or attachments manufactured by other manufacturers; such being subject to the manufacturer's warranty, if any. To the extent not prohibited by the manufacturer's warranty, North American Kitchen Solutions shall pass to you such manufacturer's warranty.

THIS WARRANTY IS IN LIEU OF ALL OTHER WARRANTIES, EXPRESS OR IMPLIED, ARISING BY LAW OR OTHERWISE, INCLUDING WITHOUT LIMITATION THE IMPLIED WARRANTIES OF MERCHANTABILITY AND FITNESS FOR A PARTICULAR PURPOSE, WHICH ARE HEREBY EXPRESSLY DISCLAIMED AND WAIVED. THIS WARRANTY CONSTITUTES NORTH AMERICAN KITCHEN SOLUTIONS'S SOLE AND EXCLUSIVE WARRANTY FOR DEFECTIVE GOODS AND PURCHASER'S SOLE AND EXCLUSIVE REMEDY FOR DEFECTIVE PRODUCTS.

No employee, agent, dealer, or other person is authorized to give any warranties on behalf of North American Kitchen Solutions or to assume for it any other liability in connection with any of its products except in writing and signed by an officer of North American Kitchen Solutions.

**LIMITATION OF LIABILITY.** North American Kitchen Solutions' cumulative liability to you and any other persons for all claims in any way relating to or arising out of the Products, including, but not limited to, any cause of action sounding in contract, tort, or strict liability, shall not exceed the total amount of the purchase price paid for those Products which are the subject of any such claim. This limitation of liability is intended to apply without regard to whether other provisions of this agreement have been breached or have proven ineffective even if North American Kitchen Solutions has been advised of the possibility of such claims or demands. In no event shall North American Kitchen Solutions be liable to you or any other person for any loss of profits or any incidental, special, exemplary, or consequential damages for any claims or demands brought by you or such other persons. BECAUSE SOME JURISDICTIONS DO NOT ALLOW THE EXCLUSION OR LIMITATION OF LIABILITY FOR CONSEQUENTIAL OR INCIDENTAL DAMAGES, THIS LIMITATION MAY NOT APPLY TO YOU.

North American Kitchen Solutions' maximum liability to you and to any end user is as set forth above. North American Kitchen Solutions makes no warranty to anyone for any products not manufactured by it and shall have no liability for any use or installation of any products (whether manufactured by North American Kitchen Solutions or other manufacturers) not specifically authorized by this sale. You acknowledge various warnings by North American Kitchen Solutions regarding the Products and its installation and use. If North American Kitchen Solutions incurs any claims, lawsuits, settlements, or expenses (including attorney fees) for any loss, injury, death or property damage including, but not limited to, claims arising out of your or any end user's installation or use of the Products, you agree to indemnify and hold North American Kitchen Solutions harmless.

**REPLACEMENT PARTS.** If replacement parts are ordered, purchaser warrants that the original components in which these replacement parts will be placed are in satisfactory working condition, and when said replacement parts are installed, the resultant installation will operate in a safe manner, at speeds and temperatures for which the original product was purchased.

**TECHNICAL ADVICE AND RECOMMENDATIONS, DISCLAIMER.** Notwithstanding any past practice or dealings or any custom of the trade, sales shall not include the furnishing of technical advice or assistance or system design. Any such assistance shall be at North American Kitchen Solutions' sole option and may be subject to additional charge(s).

North American Kitchen Solutions assumes no obligation or liability on account of any recommendations, opinions or advice as to the choice, installation or use of Products. Any such recommendations, opinions or advice are given and shall be accepted at your and the end-user's risk and shall not constitute any warranty or guarantee of such Products or their performance.

2021 © North American Kitchen Solutions, Inc. • 172 Reaser Court, Elyria, OH 44035

Toll Free: (800) 715-1014

[customerservice@naksinc.com](mailto:customerservice@naksinc.com)