

NE-17523

1700 Watt* Commercial Microwave Oven

Technical Specifications

- Power source:** 60Hz, Single phase
- Receptacle required:** NEMA 6-15/20R 
- Frequency:** 2,450MHz
- Required power:** 208: (16.6A); 230-240: (15.3A) Auto Switch
- Output*:** 1700 Watts
- Outer dimensions:** 16 5/8" w x 20" d x 13 3/8" h
- Cavity dimensions:** 13" w x 12" d x 6 7/8" h
- Net weight:** 68 lbs.
- Shipping weight:** 73 lbs.
- Shipping box size:** 19 15/16" w x 24 1/8" d x 16 7/8" h, 4.7 ft³
- Warranty:** 3 Year Parts, Labor and Travel/Shipping



To specify a Panasonic Commercial Microwave Oven:

The NE-17523 Commercial Microwave Oven meets or exceeds all safety performance and sanitation standards set for commercial food service microwave ovens by: UL, HHS, FCC and NSF.

Plus, oven shall have output power 1700 Watts*, Independently controlled top and bottom energy feed, Grab & Go door handle, Automatic Voltage Selector, patented Safety Door Seal System, 90 programmable memory pads, 5-stage cooking, 15 power levels, LCD digital display w/countdown, energy efficient LED cavity lighting, programmable lock, self-diagnostics, oven cycle counter, stackable, video training and Chef/Test Kitchen technical support.

** I.E.C. 705-88 Test Procedure. Specifications subject to change without notice.*

Receptacle Required

2 Pole
3 Wire

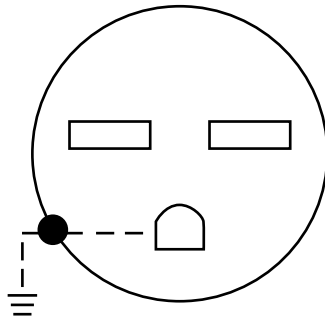

NEMA Reference:
Receptacle: 6-15/20R
Plug: 6-15P

ADA Compliance
§4.28.2 ((CFR) –
28CFR Part 36)
“For Alarms”.

§4.27 “For controls
and operating
mechanisms”.

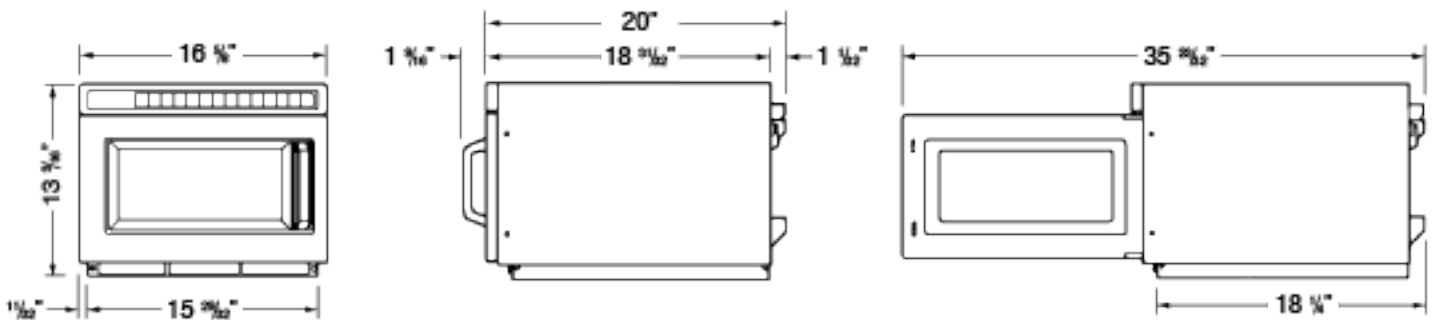

Panasonic Appliance & Commercial Group
Division of PNA
Executive Offices:
One Panasonic Way, Panazip 4A-1, Secaucus, NJ 07094
Toll Free: 1-888-350-9590
www.panasonic.com/cmo