

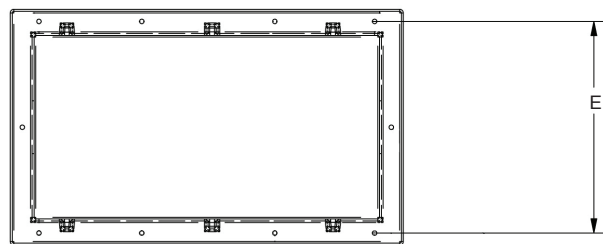

Use your smart phone to scan the above QR code to visit our website: www.bk-resources.com

Plastic Grease Traps

Model: PGT

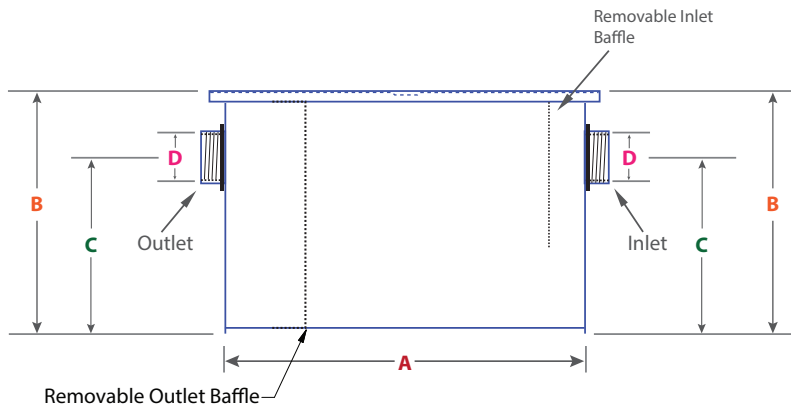
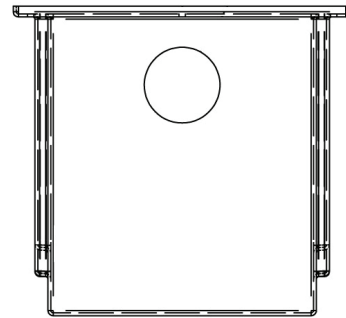

Product Specifications:

- Constructed of strong plastics which are known for superior resistance
- Removable Baffles for Ease of Maintenance
- Main Body of Grease Trap Suspended Above Floor to Avoid Corrosive Environment and Extend Life
- T-Vent Provided
- Includes threaded no hub connectors
- Designed for removing and isolating F.O.G. (Fat, Oil, Grease) from wastewater wherever food is prepared

Certifications:



Product Detail:

Model #	DIM. A	DIM. B	DIM. C	DIM. D	DIM. E
PGT-8	11.5"	10.375"	7"	2"	8"
PGT-14	15.125"	11.625"	7.6875"	2"	12.5"
PGT-20	17.5"	13.0625"	8.75"	2"	12.5"
PGT-30	18.125"	13.5"	10.375"	2"	17.375"
PGT-40	24.25"	14.5"	10.375"	3"	17.5"
PGT-50	28.5"	17.875"	13.3125"	3"	17.5"
PGT-70	32.625"	19"	13.5625"	3"	20"
PGT-100	37"	19"	13.75"	3"	23"

Due to our commitment to improving our products, specifications are subject to change without notice.

PRODUCT SPECIFICATION SHEET

