

# PPSL Heavy Duty Manual Slicer

**Model: PPSL-12HD**

PPSL-12HD

### Standard Features

- 12" special alloy knife (Rasspe®, high quality brand made in Italy), longer lasting and easier to sharpen
- 1/2HP powerful knife motor with permanently lubricated ball bearings, overload protection
- Aluminum alloy one-piece base with stain resistant and easy clean anodized finish
- Top mounted metal knife sharpener with two stones for a razor sharp cutting edge
- High quality metal index knob control gets 0 to 9/16"(14mm) precision slice thickness adjustment
- Permanent ring guard protects entire non-slicing portion of the knife, with removable cover and deflector
- Knife cover interlock prevents slicer from operating without knife cover in place
- Sealed splash zones for added sanitation and seamless edges and radius corners
- Large square food receiving plate
- Big carriage angle 42°, full gravity feed food chute
- Power switch secures no voltage release preventing inadvertent reactivation of slicer in the event of power or interlock interruption.



### Specifications

Model	Cheese Slicing Capacity	Overall Dimension				
		A	B	C	D	E
PPSL-12HD	Full Capacity	354 (14")	454 (18")	640 (25")	515(20-1/4")	850 (33-1/2")
Blade Diameter	Slicing Volume Per Day	Motor Power Watt/HP)	Slicer Thickness (mm)	Cut Capacity DxW (mm)	Net Weight KG/LBS	Package Size (cm)
300 mm/12" in)	All Day	370w/1/2HP	0-14	140x230	35/77	70x57x55



1 YEAR PARTS AND LABOR WARRANTY (US ONLY)



### PLAN VIEW

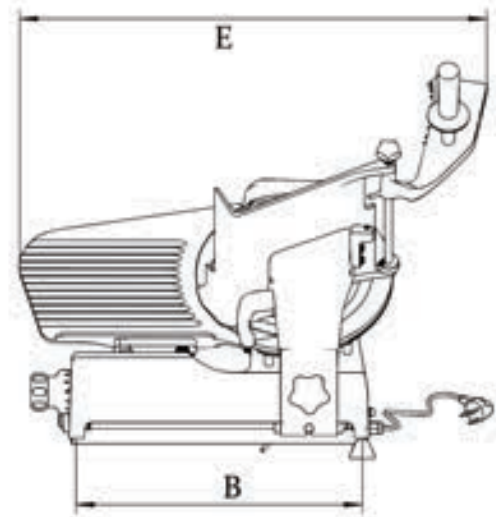
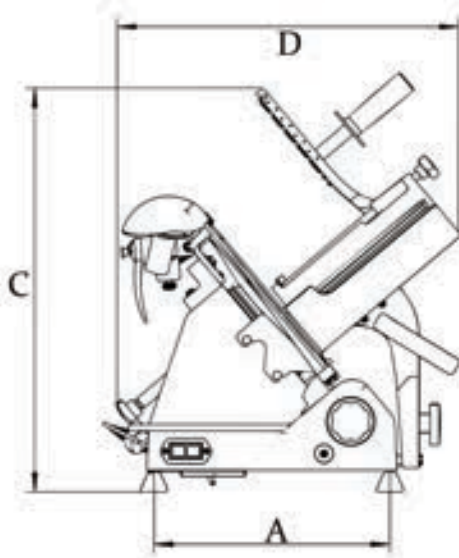

### SIDE VIEW



### Terms and Conditions

#### One Year Limited Warranty (wear items excluded)

Atosa Catering Equipment warrants its equipment against defects in materials and workmanship, subject to the following conditions:

Atosa Catering Equipment is warranted for one year, effective from the date of purchase by the original owner. A copy of the original receipt or other proof of purchase is required to obtain warranty coverage. This warranty applies to the original owner only, and is nontransferable.

Should any product fail to function in its intended manner under normal use within the limits defined in this warranty, at Atosa's discretion, such product will be replaced with a new unit by Atosa, after defective unit has been inspected. And defect has been confirmed. Atosa does not assume any liability for extended delays in replacing any item beyond its control. This warranty does not apply to plastic and non-metallic synthetic parts that may need to be replaced due to normal usage, or lack of preventative maintenance.

### ACCESSORIES

#### FINGER SAFETY GUARD



#### PLUG / RECEPTACLES

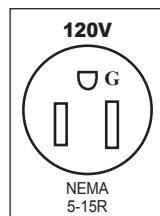

#### WHAT IS NOT COVERED BY THIS WARRANTY

Equipment that has not properly been maintained, damage from improper cleaning, and water damage to controls.

Equipment that has not been used in an appropriate manner, or has been subject to misuse, neglect, abuse, accident, alteration, negligence, damage during transit, fire, flood, or acts of God.

If the equipment has been changed, altered, modified, or repaired without express written permission from Atosa, then the manufacturer shall not be liable for any damages to any person or to any property, which may result from the use of this equipment thereafter.

For warranty and non-warranty related issues, technical support, purchase replacement parts contact Atosa toll free (855) 855-0399

\*In some cases, a 25% restocking fee may be charged to a buyer for returned items