

REFRIGERATOR MANUFACTURER
Turbo air
 more durable, efficient, beautiful

4184 E. Conant St.
 Long Beach, CA 90808
 Tel. 310-900-1000
 Fax. 310-900-1077
www.turboairinc.com

Project :	
Model # :	
Item # :	Qty :
Available W/H :	
Approval :	

Solid Door Freezer

Reach-In Top Mount
 Premiere Pro Series

Model : PRO-77F

FEATURES & BENEFITS

- **Self-cleaning condenser device** *Only at Turbo Air*
 The accumulation of dust in the condenser causes the failure or breakdown of refrigerators. Refrigerators run normally until they reach a certain level of accumulation. At some point, when they are over the limit, their performance drops quickly resulting in damage to, or disposal of the stored products in refrigerators. The self-cleaning condenser device keeps the condenser clean and prevents system failure by automatically brushing daily.
- **Digital temperature control & monitor system**

 - Keep food products safe by maintaining constant temperatures.
 - Alarms that sound when doors are not sealed shut; protect against food spoilage that originate from cold air leaks.
 - Digital display allows for easy monitoring.
 - Programs interpret the condition of refrigeration systems by self-diagnosis.
 - Smart fuzzy defrost system.
 - Automatic evaporator fan motor delays.
- **All stainless steel cabinet construction**
 The Turbo Air Premiere Pro model boasts all stainless steel interior and exterior (galvanized steel top, bottom and back). It guarantees the utmost in cleanliness and long product life. The Premiere Pro model can add a touch of style to the most refined setting.
- **Sturdy, clean stainless steel shelving**
Only Turbo Air models
 Shelves are the most important part of cleanliness as they come in direct contact with food. After a while, PVC coated wire shelves may peel, rust and lead to unsanitary conditions. Only the Turbo Air Premiere Pro series uniquely provides stainless steel shelving.
- **Hot gas condensate system** *Only Turbo Air models*
 Through Turbo Air's creative innovation, the condensate system surfaces have been specially treated to resist corrosion. This not only increases efficiency without the risk of refrigerant leakage from corrosion, but thoroughly prevents the overflow of condensate water.
- **Cold air distribution system**
- **Door pressure release device**
- **Efficient refrigeration system**
 Premiere Pro's solid door freezers are designed with oversized and balanced (CFC Free R-404A) refrigeration systems. These include efficient evaporators and condensers for faster freezing and greater efficiency.
- **High-density polyurethane insulation**
 The entire cabinet structure and solid doors are foamed-in-place using high density, CFC free polyurethane insulation.
- **LED interior lighting**
- **Top mount compressor**



**Self-Cleaning
 Condenser**



NO MAINTENANCE REQUIRED

**Freezer holds -10°F ~ 0°F for the best
 in frozen food preservation**



Model	Swing Door	CU./FT.	#of Shelves	HP	AMPS	Crated Weight (lbs.)	L x D x H † (inches)
PRO-77F	3	76	9	1 1/2	10.4	765	77 3/4 x 33 7/8 x 78

Solid Door Freezer

Reach-In Top Mount
Premiere Pro Series

Model : PRO-77F

ELECTRICAL DATA	
Voltage	115/208~230/60/1‡
Plug Type	Ⓢ NEMA L14-20 ‡
Full Load Amperes	10.4
Compressor HP	1-1/2
Feed Wires with Ground	4
Cord Length (ft.)	9
Refrigerant	R-404A
DIMENSIONAL DATA	
# of Doors	3
# of Racks Accepted	3
Net Capacity (cu. ft.)	76
Ext. Length Overall (in.)	77 3/4 (1976mm)
Ext. Depth Overall (in.)*	33 7/8 (860mm)
Ext. Height Overall (in.) †	78 (1981mm)
Int. Length Overall (in.)	73 7/8 (1876mm)
Int. Depth Overall (in.)	29 1/2 (750mm)
Int. Height Overall (in.)	58 3/4 (1493mm)
Net Weight (lbs.)	697
Gross Weight (lbs.)	765
# of Shelves	9
Shelf Size (L x D) (in.)	23 x 25 1/4 (Left/Right)
	25 1/3 x 25 1/4 (Middle)

Design and specifications subject to change without notice.

Actual shipping weight may differ due to extra packing materials for product protection.

* Depth does not include 1-1/8" for door handles.

† Height does not include 5" for caster height.

‡ PRO-77F requires 115/208-230/60Hz, single phase, 3 pole, 4 wire circuit. (NEMA L14-20)

■ WARRANTY : 3 Year Parts and Labor Warranty Additional 2 Year Warranty on Compressor

- Door locks standard
- Self-contained system
- Standard 4" dia. swivel casters with locks on the front set
- Easy replaceable one piece magnetic door gaskets
- Solid and sturdy grille design
- Legs available (optional)
- Full and half pan racks available (optional)

■ OPTIONAL ACCESSORIES :

- 5" caster, 1/2" diameter & 13 TPI: M726500100 (non-brake), M726500200 (w/ brake)
- 6" stainless steel leg: 30221M0600
- Additional stainless steel shelf: SP8F180100 (Left/Right), SP8F180200 (Middle)
- Half door bun tray rack: TSP-2224 (each holds up to six 18"L x 26"D sheet pans)
- Full door bun tray rack: TSP-2250 (each holds up to fifteen 18"L x 26"D sheet pans)

Ver.201602

PLAN VIEW

(unit : inch)

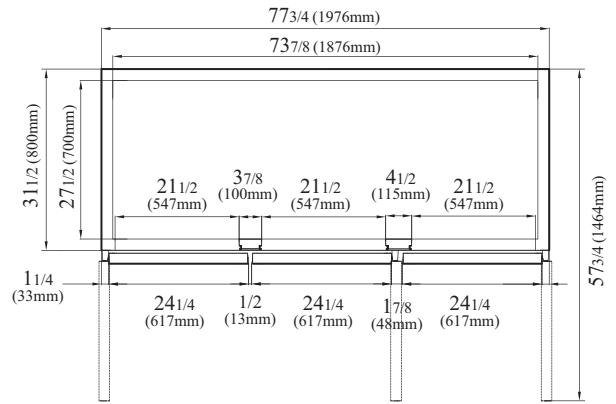

TOP VIEW

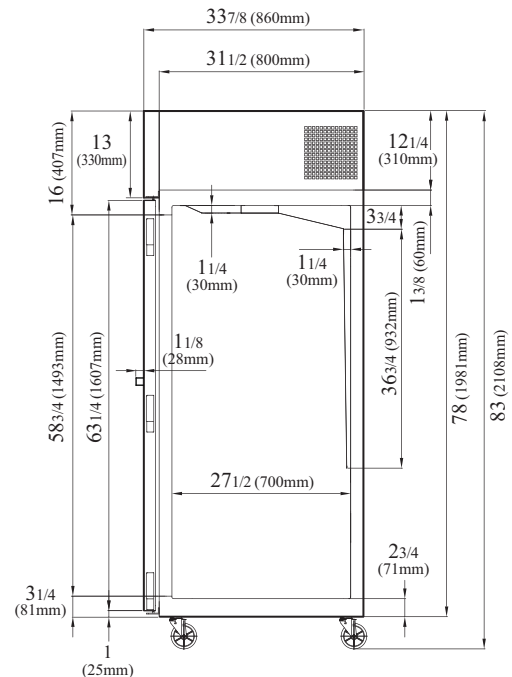

SIDE VIEW



ENERGY STAR®
Qualified

- Turbo Air : 800-627-0032
- GK : 800-500-3519
- Warranty : 800-381-7770
- AC : 888-900-1002

