



Project _____
 AIA # _____ SIS # _____
 Item # _____ Quantity _____ C.S.I. Section 114000



PW20eR advansys Pot, Pan & Utensil Washer



STANDARD FEATURES

- + Timed wash cycles; racks per hour: 13 (2 minute wash), 9 (4 minute wash), 7 (6 minute wash)
- + 2.8 gallons of water per cycle
- + Hot water sanitation machine
- + Ventless energy recovery
- + Sense-A-Temp™ booster heater capable of 70° rise
- + Front loading, split-door configuration
- + Chamber accepts 20 full-sized sheet pans, or 140 quart mixing bowl
- + Advanced service diagnostics
- + Advanced delime notification and cycle (includes booster)
- + 16 gauge stainless steel deep drawn tank
- + Microcomputer controls with advanced digital cycle/temperature display
- + Two revolving upper and lower interchangeable anti-clogging wash arms and rinse arms
- + Removable stainless steel scrap screens and scrap basket
- + Corrosion resistant pump
- + Automatic pumped drain
- + Pumped rinse
- + 33.79"h x 49.61"w door opening
- + Automatic fill
- + Delime pump standard (Advansys)
- + Electric tank heat
- + Spray hose (12')
- + Rack size: 48.8"w x 27.615"d x 4.813"h

SPECIFIER STATEMENT

Specified dishwasher will be Hobart PW20eR Advansys™ ventless pot/pan/utensil washer, front loading with split door design, (20) pan capacity, over/under rotating arms, 2/4/6 minute adjustable cycles, up to (20) racks/hour, includes: (2) flat grids, (2) tray racks & (1) flat bottom rack, pre-rinse spray hose, sanitizing with Sense-A-Temp™ 70° rise booster, pumped drain, stainless steel construction, 208-240v/60/3-ph, NSF, ENERGY STAR®.

1 year parts and labor warranty.

OPTIONS & ACCESSORIES (Available at extra cost)

- Pressure regulator valve 3/4"
- DWT-PW drain water tempering kit
- Steam pan rack (capacity for two racks)
- Flanged feet
- Water hammer arrestor kit
- Door height lowering kit
- 12 pan rack
- Combination rack

PW SERIES – PW20eR advansys

Approved by _____ Date _____ Approved by _____ Date _____



LEGEND

Electrical Connections	
E1	Electrical connection (including electric heat) 1-1/4" conduit hole, 7-1/16" AFF.
Plumbing Connections	
P1	Hot water connection incoming: 110°F water minimum. 3/4" female garden hose fitting on 6' long hose supplied with machine. 7-3/4" AFF.
P2	Drain connection: 7/8" barb fitting, 27-1/2" AFF. 6' long 7/8" hose supplied with machine.
P3	Cold water connection incoming: 90°F water maximum (65°F optimal), 3/4" female garden hose fitting on 6' long hose supplied with machine. 7-3/4" AFF.

WARNING: Plumbing and electrical connections should be made by qualified personnel who will observe all the applicable plumbing, sanitary, safety codes and National Electrical Code.

Plumbing Notes: Required flowing water pressure to the dishmachine is 15-65 PSIG. If pressures higher than 65 PSIG are present, a pressure regulating valve must be installed in the water line to the dishmachine (by others). Recommended water hardness to be 3 grains or less for best results. Pressure gauge not required on pumped rinse machines.

Miscellaneous Notes: Backflow prevention provided by NSF-approved air gap device. Single point electrical connection machines.

Electrical Specifications			
Voltage	Rated Amps	Minimum Supply Circuit Ampacity	Maximum Protective Device
208/240/60/3	58.6/64.0	70/80	80
480/60/3	35	45	45

Dishmachine not provided with internal GFCI protection.

Approximate Heat Gain to Space without Vent Hood		
Voltage	Type	BTU/Hr.
208	Latent	20,400
	Sensible	12,500
240/480	Latent	24,300
	Sensible	14,800

Vent hood is not required due to internal condensing system.

All dimensions taken from floor line may increase 1-1/2" depending on leg adjustment.

SPECIFICATIONS

Capacities

Wash Time Settings (minutes) 2, 4, 6
Racks per Hour 13 (2 min. wash), 9 (4 min. wash), 7 (6 min. wash)
Tank Capacity – Gallons 34

Motor Horsepower

Wash 4.0
Rinse 0.33

Water Consumption

U.S. Gallons per Cycle 2.8
U.S. Gallons per Hour (maximum use) 36.4
Peak Drain Flow – U.S. Gallons 26.0

Temperatures °F

Wash 150
Rinse 180
Incoming Water Temperature (minimum recommended) 45-65

Heating

Tank Heat, electric (kW) 16.4
Electric Booster (kW) 16.4

Shipping Weight (approximate) 815 lbs.

Crated Dimensions 90"H x 64"W x 40"D

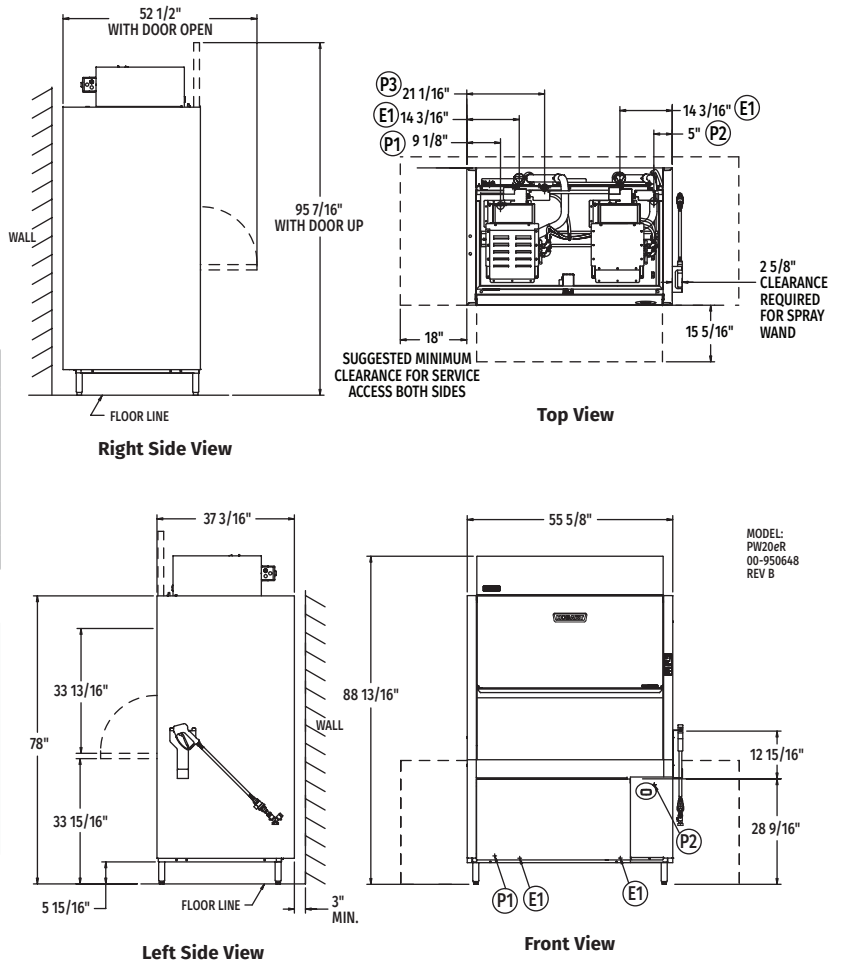

As continued product improvement is a policy of Hobart, specifications are subject to change without notice.

