



Quick Ship

Walk-In Coolers & Freezers
 With Self-Contained Refrigeration
 Systems



Equipped with
SELF-CONTAINED
 Capsule Pak™
 refrigeration
 systems

FEATURES

- Cooler or freezer models
- Sizes from 4' x 6' to 10' x 14'
- Three heights: 6'7" & 7'7" with floor; 7'4" floorless
- Indoor or outdoor models
- Two temperatures: +35°F, -10°F
- Ceiling mount Capsule Pak refrigeration system (ordered separately)
- Air-cooled condensing unit
- Electronic controller
- 26 gauge corrosion resistant stucco embossed coated steel on all surfaces except interior floor
- Smooth aluminum interior floor (on models with floor)
- Floorless models supplied with NSF listed vinyl sealers
- Full 4" thick panels foamed-in-place with EPA-compliant polyurethane insulation
- 26" wide, self-closing door
- Heavy duty adjustable cam-lift hinges
- Spring actuated door closer
- Deadbolt locking handle with independent key/padlock feature and inside safety release
- Magnetic gasket
- Digital thermometer and light switch
- Floor double sweep gasket
- Perimeter door heater wire
- High output low profile LED light positioned above the door to prevent interference with shelving or product
- UL, C-UL listing on complete Capsule Pak refrigeration systems**
- NSF, UL flame spread 25 or less on all foam cores; UL and CSA electrical listing on door sections ***
- City of Houston listed
- California State listed
- CN UL flame spread listed
- DOE compliant
- Oregon State listed
- USDA accepted
- 15 year panel warranty
- 18 months parts & labor warranty

- **INDOOR MODELS:**
 - Hot gas condensate vaporizer
- **OUTDOOR MODELS:**
 - White membrane roof and trim
 - -20°F ambient controls

OPTIONS

(Most options available two weeks from receipt of order. Please contact us for specific questions)

- Heights: 8'7" with floor, 8'4" without floor
- U-shaped shelving system
- Floor tread plate kit
- Exterior ramp
- Door hood (outdoor models)
- Heater kit for outdoor use with medium temp applications where ambient conditions may go below 32°F
- Leak detector/alarm (may be a requirement in some areas)
- Five year compressor warranty

* Some models ship in 5 or 10 days

** C-UL is Underwriters Laboratories Safety Certification Mark which indicates that UL has tested the equipment to applicable CSA Standards.

*** UL Sanitation is Underwriters Laboratories Sanitation Mark which indicates that UL has tested the equipment to applicable NSF Standards.



QUICK SHIP

WALK-IN COOLERS & FREEZERS WITH SELF-CONTAINED REFRIGERATION SYSTEMS

WALK-IN SPECIFICATIONS

Quick Ship walk-ins are built of modular panels and are insulated with foamed-in-place EPA-compliant polyurethane insulation. Each panel is designed to ensure ease of installation, long term reliability and high insulating efficiency.

A. All panels are manufactured with male and female mating rails to ensure proper alignment during installation. The polyurethane insulation wraps around the return bend metal seams on both section to create a lightweight panel of exceptional strength and durability. All panels are a full four (4) inches thick and provide a superior insulating value.

B. The foamed-in-place cam locking fasteners ensure an airtight seal for maximum energy efficiency.

C. Quick Ship panel gaskets located around the outer perimeter of the panel are continuous, without cuts or breaks at corners. The patented gasket design provides a foamed-in-place gasket as an integral part of the panel. Gaskets cannot fall off or pull off during shipment or installation.

D. Panels lock together tightly for an energy efficient walk-in.

E. Edge caps for ends of floor and ceiling panels are foamed-in-place rather than overlapped or mechanically fastened. Edge caps cannot come loose, and they stay in place through the life of the walk-in.

F. Panel Finishes: Interior and exterior panels are fabricated with 26 gauge corrosion resistant stucco embossed coated steel. Models supplied with a floor will include a smooth aluminum interior floor surface.

G. Insulation: Panels are four (4) inches thick, metal clad and foamed-in-place with HFO polyurethane insulation which is HFC free.

The R-values for 4" HFO panels are:

Cooler:

Walls/Ceilings R-value 25

Doors R-value 25

Freezer:

Walls/Ceilings R-value 32

Doors R-value 32

Floors R-value 28

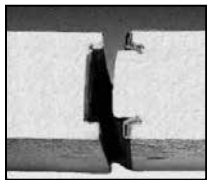

A.



B.

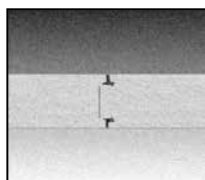

C.

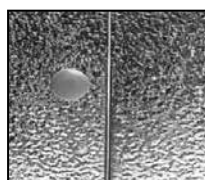

D.



E.

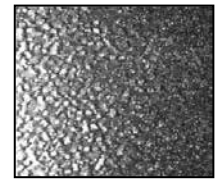

F.

AVAILABLE SIZES

The Standard Series of Quick Ship walk-ins are all 6'-7" high and are all supplied with a floor. The sizes available are as follows: 4' wide x 6' long, 6' wide x 6' long, 6' wide x 8' long, 6' wide x 10' long, 6' wide x 12' long, 8' wide x 8' long, and 8' wide x 10' long.

The 77 Series of Quick Ship walk-ins are all 7'-7" high and are all supplied with a floor. The sizes available are as follows: 6' wide x 6' long, 6' wide x 8' long, 6' wide x 10' long, 6' wide x 12' long, 8' wide x 8' long, and 8' wide x 10' long.

The 74 Series of Quick Ship walk-ins are all 7'-3⁵/₈" high and are all supplied without a floor. Wall panels are installed on top of NSF listed vinyl sealers provided. The sizes available are as follows: 6' wide x 6' long, 6' wide x 8' long, 6' wide x 10' long, 6' wide x 12' long, 8' wide x 8' long, and 8' wide x 10' long.

OUTDOOR MODELS

All Quick Ship walk-ins installed outdoors include a weather protection kit consisting of: One piece, 35 mill, white membrane roof material which requires no seaming or gluing to the top of the Quick Ship walk-in ceiling panels.

Metal trim for flashing the membrane roof material to the side of the Quick Ship walk-in wall panels is included.

Trim is secured to the Quick Ship wall panels with self-drilling and self-tapping TEK screws. In applications where the Quick Ship walk-in is installed next to a building, the trim can be used to secure the turned up membrane roof material to the building wall, with fasteners supplied. Door rain hoods are an option and should be included on installations where the door panels are exposed to the outdoor weather.

DOOR

Door sections are factory tested to assure proper fit, performance and alignment. All doors feature a stepped profile design that serves as a barrier to air flow which results in an energy efficient door system. Door sections are 4" thick, metal clad and foamed-in-place with EPA-compliant polyurethane insulation.

Each Quick Ship walk-in compartment is equipped with a 26" wide door opening. The height of the door opening varies with the series of Quick Ship walk-in ordered. The Standard Series (6'7" high) has a 66" high door opening and the 74 and 77 Series Quick Ship walk-ins have a 78" high door opening. The door is self-closing, flush mounted, infitting and constructed to incorporate heavy duty, molded ABS breaker which is permanently foamed-in-place.

Doors are available with right or left side hinges and include two field adjustable cam-lift hinges with locking set screw, top hinge spring loaded, spring actuated door closer, NL 9800 deadbolt locking handle with independent key/padlock feature and inside safety release. The doors are pre-hung in a four foot wide frame panel which is equipped with replaceable perimeter heater wire, magnetic stainless steel trim, digital thermometer, vapor proof LED light fixture and switch with exterior pilot indicator light.

The door section is completely pre-wired within concealed conduit inside the door frame panel. 120/60/1 electrical is field wired to a junction box which is surface mounted next to the interior frame above the vapor proof LED light fixture.

Hinges and door handle are mounted to 1/2" synthetic insulated tapping plates. Each door section is complete with a fiberglass reinforced plastic heated threshold.

DOOR OPENING SIZE		
W	H	MODEL
26"	66"	STD Series
26"	78"	74 Series
26"	78"	77 Series

These doors are designed and certified for use in walk-in cooler applications.

DOOR MODEL NUMBER	ENERGY CONSUMPTION (KWH/DAY)	DOOR SURFACE AREA (SQ. FT.)	ELECTRICAL	WATTS	AMPS
QS26X66	2.37	13.40	120/60/1	100.80	0.84
QS26X78	2.49	15.80	120/60/1	106.07	0.88



Deadbolt-locking handle



Spring actuated door closer



LED light fixture

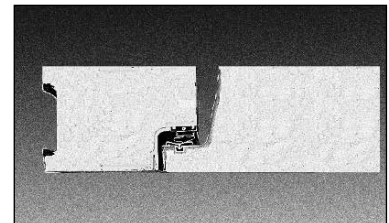

Doors feature a stepped profile design



Digital thermometer/light switch

These doors are designed and certified for use in walk-in freezer applications.

DOOR MODEL NUMBER	ENERGY CONSUMPTION (KWH/DAY)	DOOR SURFACE AREA (SQ. FT.)	ELECTRICAL	WATTS	AMPS
QS26X66	6.68	13.40	120/60/1	196.07	1.63
QS26X78	7.01	15.80	120/60/1	207.07	1.73



QUICK SHIP

WALK-IN COOLERS & FREEZERS WITH SELF-CONTAINED REFRIGERATION SYSTEMS

FLOOR CONSTRUCTION

Floor panels (when supplied) are similar in construction to the wall panels except they are made to withstand uniformly distributed floor loads of up to 800 pounds per square foot. The interior floor metal is smooth aluminum.

The 74 Series, floorless models, are supplied with a patented vinyl floor sealer to stop conductivity at floor level. This unique sealer sits flat on existing floors and fits tightly against the interior/exterior wall panels. The walk-in wall panel is supported on the shoulder of the sealer so the foam edge is free of compressing weight. The vinyl floor sealer is NSF listed.

SHELVING KITS

Shelving kits specifically designed for each Quick Ship walk-in configuration are offered as an optional extra. These kits are shipped with the Quick Ship walk-in and Capsule Pak refrigeration system so that all necessary components are at your location promptly when you need them. The shelving sets are coded to correspond to the Quick Ship walk-in configuration ordered and are offered in either three or four tier.

SHELVING SYSTEM TYPES

A. Green Kote™ Shelving: Electrostatically applied green baked epoxy over zinc steel and brite basic wire. Thickness: 2-3 mill. 15 year guarantee against corrosion.

B. Standard Chrome Kote™ Shelving: Plated quality wire and steel. Surface nickel chrome plated.

Select the shelving finish of your choice. Shelving posts are engineered for maximum strength. Shelves are adjustable on 2" centers. All shelves are NSF listed and are zinc coated with a heavy layer of Protoxy for a maximum life span under humid storage conditions. Special clips are utilized to gain the maximum square footage of storage space for each Quick Ship model. 14", 18" and 24" wide shelves are used as required for maximum storage capacity in each set. This wire shelving is ideal for storage of all refrigerated or frozen products.

SHELVES

Shelves to have #9 (.148") ga. crosswires spaced 3/4" on centers with crossbraces 1/4" (.192") minimum of 4-3/4" on center.

- **Shelf Frames:** Channel to be 9/16" x 1" x .075" thick.
- **Shelf Collars:** A round tapered 1-5/16" high steel collar to be welded at each corner.

POSTS

Posts to be .062" thick 1" O.D. round tubing notched every 2" on each corner of the post.

POST LEVELERS

Installed on the bottom of each post is nylon housing for a steel leveler 3/8"-16 x 1-3/4".

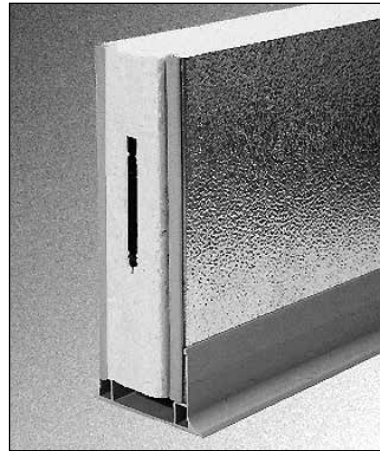

Floorless models are supplied with a patented vinyl floor sealer



Shelving system types include Green Kote™ and Chrome Kote™

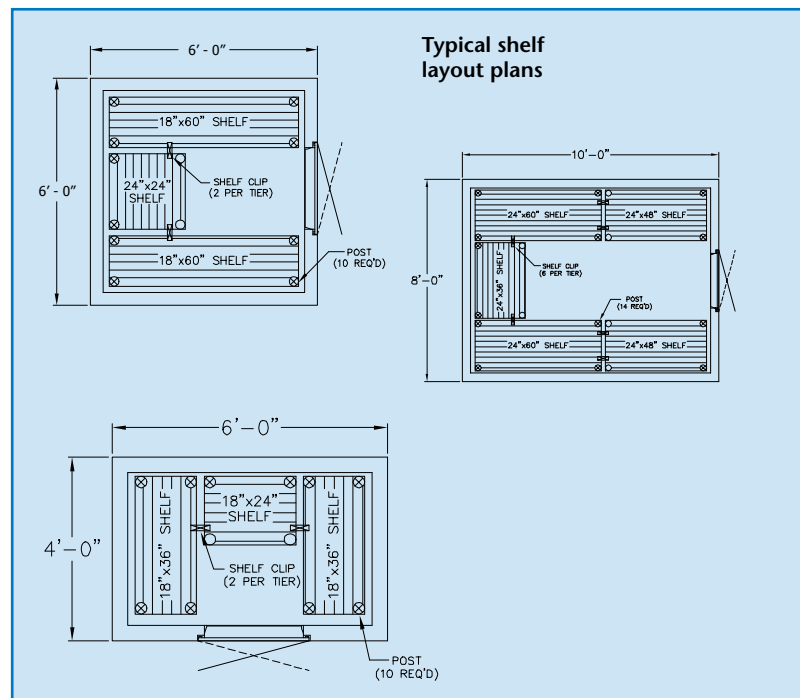

STANDARD CAPSULE PAK™ REFRIGERATION SYSTEMS

SELF-CONTAINED ONE-PIECE MODELS

A condensing unit and evaporator coil contained in a single housing ready to mount on top of your Master-Bilt walk-in.

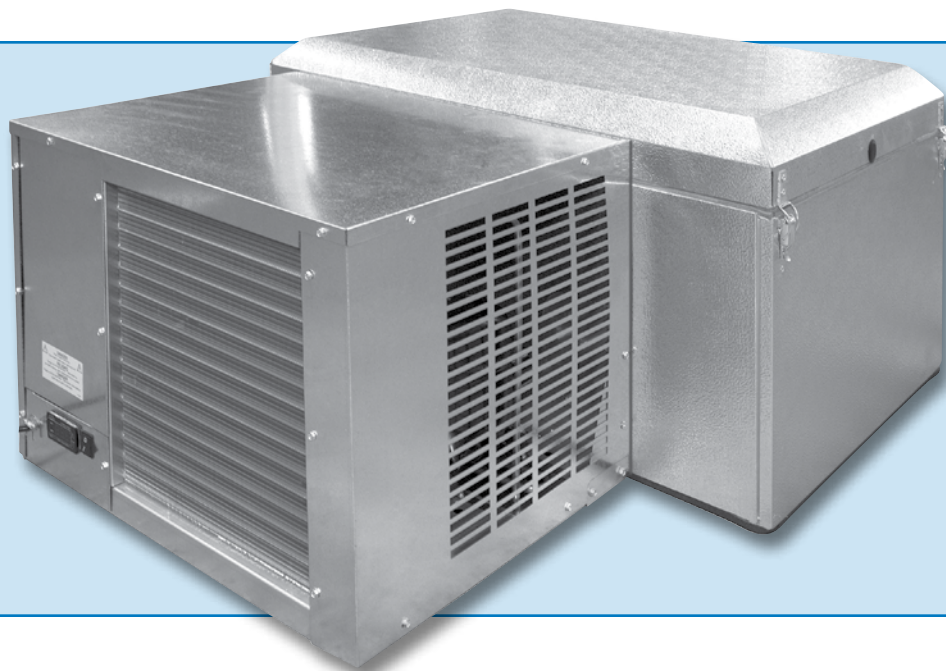

The evaporator coil is flush mounted in the walk-in ceiling panel for maximum interior storage space. The standard electronic controller system provides increased reliability, connectivity and food safety. Installation costs are also greatly reduced because there's no piping or other components requiring field installation. All models are factory assembled, wired, charged, tested and fully equipped for fast and easy insertion into a factory prepared walk-in ceiling opening.

FEATURES

- Available for coolers or freezers
- Two temperatures: +35°F and -10°F
- Indoor and outdoor ceiling mount models
- Air cooled condensing unit
- Scroll™ compressors on most models
- Automatic condensate evaporator (indoor models only)
- Electronic controller system
- Electronic control provided for automatic defrost on both coolers and freezers
- All models feature standard cord and plug eliminating the need for field connection
- UL and C-UL electrical listing on complete Capsule Pak refrigeration systems*
- AWEF compliant
- -20°F ambient controls (outdoor models)
- 18 months parts and labor warranty

OPTIONS

(Most options are available two weeks from receipt of order. Please contact us for specific questions)

- Heater kit for outdoor use with medium temp applications where ambient conditions may go below 32°F
- 5 year compressor warranty

* C-UL is Underwriters Laboratories Safety Certification Mark which indicates that UL has tested the equipment to applicable CSA Standards.



QUICK SHIP

WALK-IN COOLERS & FREEZERS WITH SELF-CONTAINED REFRIGERATION SYSTEMS

CAPSULE PAK™ REFRIGERATION SYSTEM SPECIFICATIONS

Capsule Pak refrigeration systems consist of a single assembly pre-charged condensing unit and evaporator coil factory assembled, wired, tested and ready for insertion into a factory prepared walk-in ceiling opening.

The Capsule Pak system has a flush coil which keeps all components outside the walk-in storage area, allowing more storage inside. Ceiling mount models are available indoor or outdoor installations. Models are available for interior compartment design temperatures of +35°F and -10°F. Installation is fast and easy with no plumbing required on indoor units.

The evaporator section is designed to be located entirely outside the walk-in with no intrusions into the refrigerated space. The evaporator enclosure is constructed utilizing foamed-in-place polyurethane insulation and equipped with a removable, gasketed access cover. Capsule Pak models use high efficiency EC evaporator fan motors to circulate air throughout the walk-in.

All indoor Capsule Pak models are equipped with either a discharge gas condensate vaporizer or an optional electric condensate vaporizer. All outdoor Capsule Pak models are equipped with low ambient controls consisting of crankcase heater and flooded condenser head pressure control.

All standard ceiling mount Capsule Pak refrigeration systems are UL and C-UL listed and AWEF compliant. Note: Allow minimum of 4" clearance above and 24" on each side of the Capsule Pak system for installation. Consideration should be given to accessibility for service and free condenser air flow. Consult factory with installation questions.



Self-contained Capsule Pak systems are conveniently located on top of the walk-in to maximize available floor space. Available in indoor and outdoor models for single or dual walk-in compartments.

STANDARD ELECTRONIC CONTROLLER ON SELF-CONTAINED CAPSULE PAK SYSTEMS



- More precise and reliable temperature control compared to all-mechanical systems
- Patented design saves up to 27% more energy than an all-mechanical system
- Demand Defrost technology initiates defrosts only as needed for further energy savings
- Online data for instant notification of error codes and settings

FLOOR PLAN LAYOUTS FOR SINGLE ROOM COOLERS OR FREEZERS

Model numbers indicate the door location on the standard Quick Ship layouts

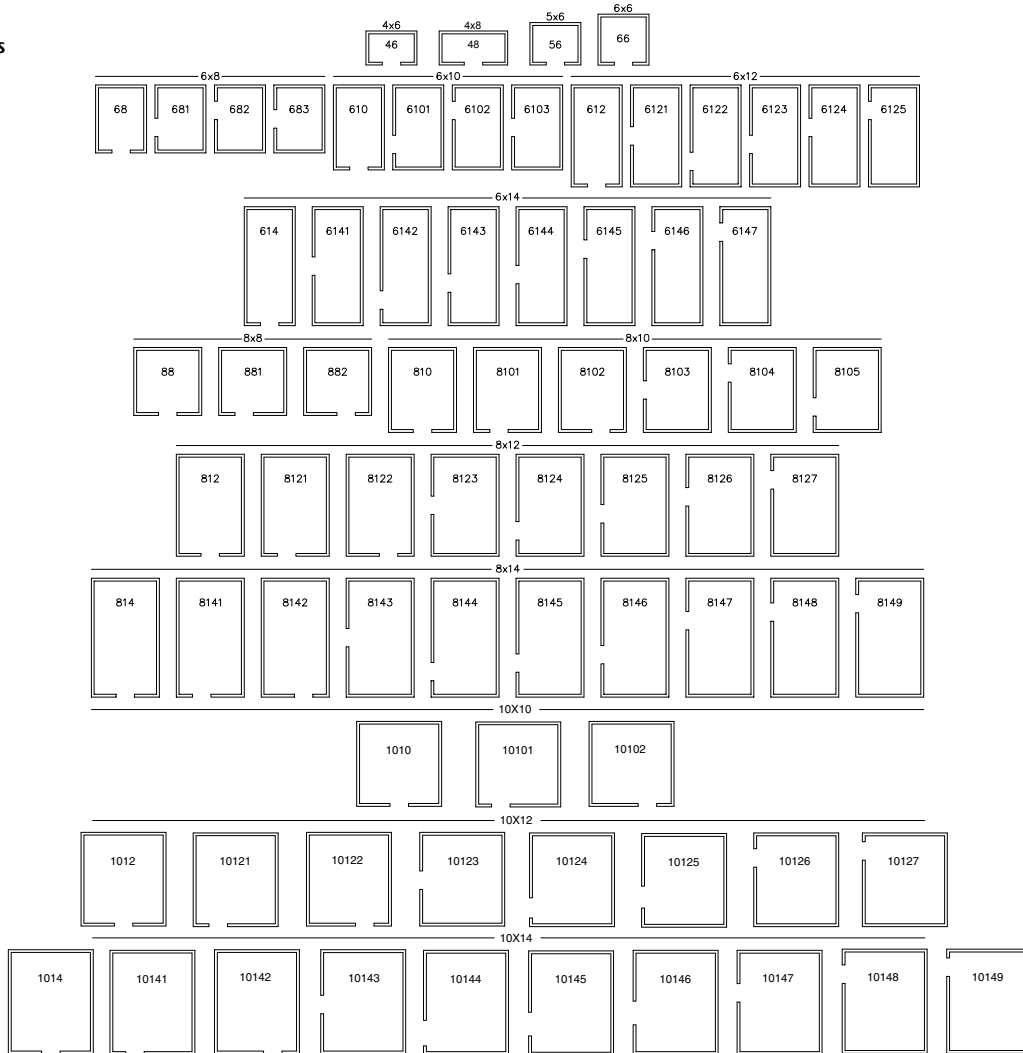

PHYSICAL SPECIFICATIONS

6'7" HIGH		7'4" HIGH & 7'7" HIGH	
MODEL	CAPACITY CU. FT.	MODEL	CAPACITY CU. FT.
QS46 (4' x 6')	105	QS7746	123
QS56 (5' x 6')	137	QS7756	159
QS66 (6' x 6')	168	QS7766	196
QS68 (6' x 8')	231	QS7768	270
QS610 (6' x 10')	295	QS77610	344
QS612 (6' x 12')	357	QS77612	418
QS614 (6' x 14')	420	QS77614	490
QS88 (8' x 8')	318	QS7788	372
QS810 (8' x 10')	404	QS77810	473
QS812 (8' x 12')	490	QS77812	574
QS814 (8' x 14')	578	QS77814	675
QS1010 (10' x 10')	515	QS771010	602
QS1012 (10' x 12')	625	QS771012	731
QS1014 (10' x 14')	736	QS771014	860



QUICK SHIP

WALK-IN COOLERS & FREEZERS WITH SELF-CONTAINED REFRIGERATION SYSTEMS

MATCHING CAPSULE PAK™ REFRIGERATION SYSTEMS

QUICK SHIP MODEL	SELF-CONTAINED ONE-PIECE CEILING MOUNT			
	-10°F		+38°F to +35°F	
MODEL	MODEL	BTUH*	MODEL	BTUH*
6'7" HIGH WITH FLOOR				
QS46	CPF060JC-S-4-EV	2250	CPB050JC-S-O-EV	4400
QS56	CPF075JC-S-4-EV	3130	CPB050JC-S-O-EV	4400
QS66	CPF075JC-S-4-EV	2637	CPB050JC-S-O-EV	4400
QS68	CPF100JC-S-4-EV	3500	CPB075JC-S-4-EV	6385
QS610	CPF100JC-S-4-EV	3444	CPB075JC-S-4-EV	6385
QS612	CPF150JC-S-4-EV	4509	CPB075JC-S-4-EV	6385
QS614	CPF200JC-S-4-EV	6725	CPB075JC-S-4-EV	6385
QS88	CPF150JC-S-4-EV	4509	CPB075JC-S-4-EV	6385
QS810	CPF150JC-S-4-EV	4509	CPB075JC-S-4-EV	6385
QS812	CPF150JC-S-4-EV	4509	CPB075JC-S-4-EV	6385
QS814	CPF200JC-S-4-EV	6725	CPB075JC-S-4-EV	6385
QS1010	CPF200JC-S-4-EV	6725	CPB075JC-S-4-EV	6385
QS1012	CPF200JC-S-4-EV	6725	CPB075JC-S-4-EV	6385
QS1014	CPF200JC-S-4-EV	6725	CPB100JC-S-4-EV	7300
6'7" HIGH WITH FLOOR OUTDOOR				
QOD46	CPF060JC-E-4-EV	2135	CPB050JC-E-O-EV	4115
QOD56	CPF075JC-E-4-EV	2875	CPB050JC-E-O-EV	4115
QOD66	CPF075JC-S-4-EV	2875	CPB050JC-E-O-EV	4115
QOD68	CPF100JC-S-4-EV	3210	CPB050JC-E-O-EV	4115
QOD610	CPF100JC-E-4-EV	3210	CPB075JC-E-4-EV	5802
QOD612	CPF150JC-E-4-EV	4362	CPB075JC-E-4-EV	5802
QOD614	CPF200JC-E-4-EV	6350	CPB100JC-E-4-EV	6884
QOD88	CPF100JC-S-4-EV	3210	CPB075JC-E-4-EV	5802
QOD810	CPF100JC-S-4-EV	3210	CPB075JC-E-4-EV	5802
QOD812	CPF100JC-S-4-EV	3210	CPB100JC-E-4-EV	6884
QOD814	CPF200JC-E-4-EV	6350	CPB100JC-E-4-EV	6884
QOD1010	CPF200JC-E-4-EV	6350	CPB100JC-E-4-EV	6884
QOD1012	CPF200JC-E-4-EV	6350	CPB100JC-E-4-EV	6884
QOD1014	CPF200JC-E-4-EV	6350	CPB100JC-E-4-EV	6884
7' 4" HIGH LESS FLOOR - INDOOR ONLY				
QS7446	N/A	N/A	CPB050JC-S-O-EV	**
QS7456	N/A	N/A	CPB050JC-S-O-EV	**
QS7466	N/A	N/A	CPB050JC-S-O-EV	**
QS7468	N/A	N/A	CPB075JC-S-4-EV	6250
QS74610	N/A	N/A	CPB075JC-S-4-EV	6250
QS74612	N/A	N/A	CPB075JC-S-4-EV	6250
QS74614	N/A	N/A	CPB075JC-S-4-EV	6250
QS7488	N/A	N/A	CPB075JC-S-4-EV	6250
QS74810	N/A	N/A	CPB075JC-S-4-EV	6250
QS74812	N/A	N/A	CPB075JC-S-4-EV	6250
QS74814	N/A	N/A	CPB100JC-S-4-EV	6250
QS741010	N/A	N/A	CPB075JC-S-4-EV	6250
QS741012	N/A	N/A	CPB100JC-S-4-EV	8484
QS741014	N/A	N/A	CPB100JC-S-4-EV	8484

*BTUH calculated using 16 hour design runtimes on coolers and 20 hour design runtimes on freezers

**Contact factory for information.

QUICK SHIP MODEL	SELF-CONTAINED ONE-PIECE CEILING MOUNT			
	-10°F		+38°F to +35°F	
	MODEL	BTUH*	MODEL	BTUH*
7' 7" HIGH WITH FLOOR				
QS7746	CPF075JC-S-4-EV	3130	CPB050JC-S-O-EV	4400
QS7748	CPF075JC-S-4-EV	3130	CPB050JC-S-O-EV	4400
QS7756	CPF075JC-S-4-EV	3130	CPB050JC-S-O-EV	4400
QS7766	CPF100JC-S-4-EV	3500	CPB050JC-S-O-EV	4400
QS7768	CPF100JC-S-4-EV	3500	CPB075JC-S-4-EV	6366
QS77610	CPF150JC-S-4-EV	4509	CPB075JC-S-4-EV	6366
QS77612	CPF150JC-S-4-EV	4509	CPB075JC-S-4-EV	6366
QS77614	CPF200JC-S-4-EV	6725	CPB075JC-S-4-EV	6366
QS7788	CPF150JC-S-4-EV	4509	CPB075JC-S-4-EV	6366
QS77810	CPF150JC-S-4-EV	4509	CPB075JC-S-4-EV	6366
QS77812	CPF200JC-S-4-EV	6725	CPB075JC-S-4-EV	6366
QS77814	CPF200JC-S-4-EV	6725	CPB100JC-S-4-EV	7300
QS771010	CPF200JC-S-4-EV	6725	CPB075JC-S-4-EV	6366
QS771012	CPF200JC-S-4-EV	6725	CPB100JC-S-4-EV	7300
QS771014	CPF200JC-S-4-EV	6725	CPB100JC-S-4-EV	7300
7' 7" HIGH WITH FLOOR OUTDOOR				
QOD7746	CPF075JC-E-4-EV	2875	CPB050JC-E-O-EV	4115
QOD7756	CPF075JC-E-4-EV	2875	CPB050JC-E-O-EV	4115
QOD7766	CPF075JC-E-4-EV	2875	CPB050JC-E-O-EV	4115
QOD7768	CPF100JC-E-4-EV	3210	CPB050JC-E-O-EV	4115
QOD77610	CPF100JC-E-4-EV	3210	CPB075JC-E-4-EV	5802
QOD77612	CPF150JC-E-4-EV	4362	CPB100JC-E-4-EV	6884
QOD77614	CPF200JC-E-4-EV	6350	CPB100JC-E-4-EV	6884
QOD7788	CPF150JC-E-4-EV	6350	CPB075JC-E-4-EV	5802
QOD77810	CPF150JC-E-4-EV	6350	CPB075JC-E-4-EV	5802
QOD77812	CPF200JC-E-4-EV	6350	CPB100JC-E-4-EV	6884
QOD77814	CPF200JC-E-4-EV	6350	CPB100JC-E-4-EV	6884
QOD77B814	CPF200JC-E-4-EV	6350	CPB100JC-E-4-EV	6884
QOD771010	CPF200JC-E-4-EV	6350	CPB075JC-E-4-EV	5802
QOD771012	CPF200JC-E-4-EV	6350	CPB100JC-E-4-EV	6884
QOD771014	CPF200JC-E-4-EV	6350	CPB100JC-E-4-EV	6884
8'4" HIGH LESS FLOOR				
QS8466	N/A	N/A	CPB050JC-S-O-EV	4400
QS8468	N/A	N/A	CPB075JC-S-4-EV	6366
QS84610	N/A	N/A	CPB075JC-S-4-EV	6366
QS84612	N/A	N/A	CPB075JC-S-4-EV	6366
QS84614	N/A	N/A	CPB100JC-S-4-EV	7300
QS8488	N/A	N/A	CPB075JC-S-4-EV	6366
QS84810	N/A	N/A	CPB075JC-S-4-EV	6366
QS84812	N/A	N/A	CPB100JC-S-4-EV	7300
QS84814	N/A	N/A	CPB100JC-S-4-EV	7300
8'7" HIGH WITH FLOOR				
QS8766	CPF100JC-S-4-EV	3500	CPB050JC-S-O-EV	4400
QS8768	CPF100JC-S-4-EV	3500	CPB075JC-S-4-EV	6366
QS87610	CPF150JC-S-4-EV	4509	CPB075JC-S-4-EV	6366
QS87612	CPF150JC-S-4-EV	4509	CPB075JC-S-4-EV	6366
QS87614	CPF200JC-S-4-EV	6725	CPB075JC-S-4-EV	6366
QS8788	CPF150JC-S-4-EV	4509	CPB075JC-S-4-EV	6366
QS87810	CPF150JC-S-4-EV	4509	CPB075JC-S-4-EV	6366
QS87812	CPF200JC-S-4-EV	6725	CPB100JC-S-4-EV	7300
QS87814	CPF200JC-S-4-EV	6725	CPB100JC-S-4-EV	7300
8'7" HIGH WITH FLOOR OUTDOOR				
QOD8766	CPF100JC-E-4-EV	3210	CPB050JC-E-O-EV	4115
QOD8768	CPF100JC-E-4-EV	3210	CPB050JC-E-O-EV	4115
QOD87610	CPF150JC-E-4-EV	4362	CPB075JC-E-4-EV	5802
QOD87612	CPF150JC-E-4-EV	4362	CPB100JC-E-4-EV	6884
QOD87614	CPF200JC-E-4-EV	6350	CPB100JC-E-4-EV	6884
QOD8788	CPF150JC-E-4-EV	4362	CPB075JC-E-4-EV	5802
QOD87810	CPF150JC-E-4-EV	4362	CPB100JC-E-4-EV	6884
QOD87812	CPF200JC-E-4-EV	6350	CPB100JC-E-4-EV	6884
QOD87814	CPF200JC-E-4-EV	6350	CPB100JC-E-4-EV	6884

*BTUH calculated using 16 hour design runtimes on coolers and 20 hour design runtimes on freezers
**Contact factory for information.



QUICK SHIP

WALK-IN COOLERS & FREEZERS WITH SELF-CONTAINED REFRIGERATION SYSTEMS

CAPSULE PAK™ PHYSICAL SPECIFICATIONS

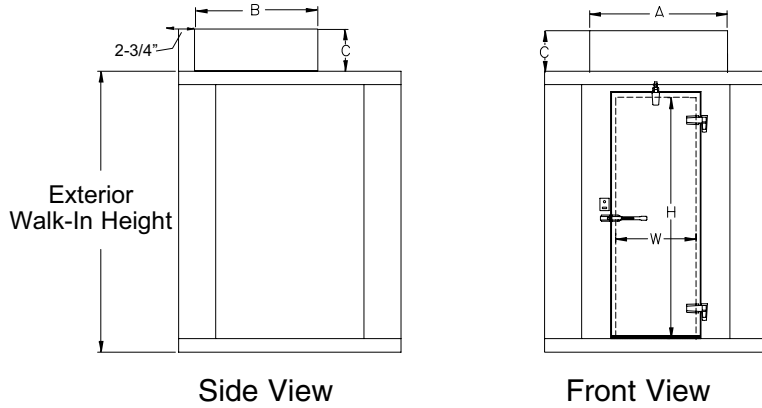

DOOR OPENING SIZE		
W	H	MODEL
26"	66"	STD Series
26"	78"	74 Series
26"	78"	77 Series

CEILING MOUNT MODEL NO.	"A"	"B"	"C"
CPB050JC-*.0-EV	41-1/8"	50-1/2"	20-5/8"
CPB075JC-*.4-EV	41-1/8"	50-1/2"	20-5/8"
CPB100JC-*.4-EV	41-1/8"	50-1/2"	20-5/8"
CPF060JC-*.4-EV	41-1/8"	50-1/2"	20-5/8"
CPF075JC-*.4-EV	41-1/8"	50-1/2"	20-5/8"
CPF100JC-*.4-EV	41-1/8"	50-1/2"	20-5/8"
CPF150JC-*.4-EV	45-3/4"	53-3/8"	24-3/4"
CPF200JC-*.4-EV	45-3/4"	53-3/8"	24-3/4"

* Insert "S" for indoor model and "E" for outdoor

NOTE:

- Consideration must be given to accessibility for service & free condenser air flow. Consult factory with installation questions. Proper condensing unit ventilation must be provided. The factory recommends 200cfm of fresh air in the surrounding area with ample clearance around the condensing unit.
- +90°F ambient or less and 50% RH
- Subject to change without notice

CAPSULE PAK™ SYSTEM ELECTRICAL DATA

INDOOR REFRIGERATION SYSTEMS (CORD AND PLUG CONNECTED)

MODEL	REFRIGERANT	ELECTRICAL	TOTAL SYSTEM AMPS	TOTAL DEFROST AMPS	NEMA PLUG	AWEF
CPB050JC-S-0-EV	R-449A	115/60/1	9.3	N/A	5-15P	5.61
CPB075JC-S-4-EV	R-449A	208-230/60/1	5.5	N/A	6-15P	5.61
CPB100JC-S-4-EV	R-449A	208-230/60/1	7.5	N/A	6-15P	5.61
CPF060JC-S-4-EV	R-449A	208-230/60/1	8.0	5.7	6-15P	1.99
CPF075JC-S-4-EV	R-449A	208-230/60/1	8.5	5.7	6-15P	2.08
CPF100JC-S-4-EV	R-449A	208-230/60/1	9.6	5.7	6-15P	2.11
CPF150JC-S-4-EV	R-449A	208-230/60/1	11.1	8.7	6-15P	2.22
CPF200JC-S-4-EV	R-449A	208-230/60/1	15.7	8.7	6-20P	2.43

OUTDOOR REFRIGERATION SYSTEMS (CORD AND PLUG CONNECTED)

MODEL	REFRIGERANT	ELECTRICAL	TOTAL SYSTEM AMPS	TOTAL DEFROST AMPS	NEMA PLUG	AWEF
CPB050JC-E-0-EV	R-449A	115/60/1	9.3	N/A	5-15P	7.60
CPB075JC-E-4-EV	R-449A	208-230/60/1	5.5	N/A	6-15P	7.60
CPB100JC-E-4-EV	R-449A	208-230/60/1	7.5	N/A	6-15P	7.60
CPF060JC-E-4-EV	R-449A	208-230/60/1	8.0	5.7	6-15P	2.89
CPF075JC-E-4-EV	R-449A	208-230/60/1	8.5	5.7	6-15P	2.92
CPF100JC-E-4-EV	R-449A	208-230/60/1	9.6	5.7	6-15P	2.95
CPF150JC-E-4-EV	R-449A	208-230/60/1	11.1	8.7	6-20P	3.03
CPF200JC-E-4-EV	R-449A	208-230/60/1	15.7	8.7	6-20P	3.15

Note:

- Consult factory for application specifics, pricing and ship date availabilities.
- All self-contained Capsule Pak systems require a single power supply.



QUICK SHIP

WALK-IN COOLERS & FREEZERS WITH SELF-CONTAINED REFRIGERATION SYSTEMS

REMOTE CAPSULE PAK™ SYSTEMS (ALL WITH R-449A REFRIGERANT)

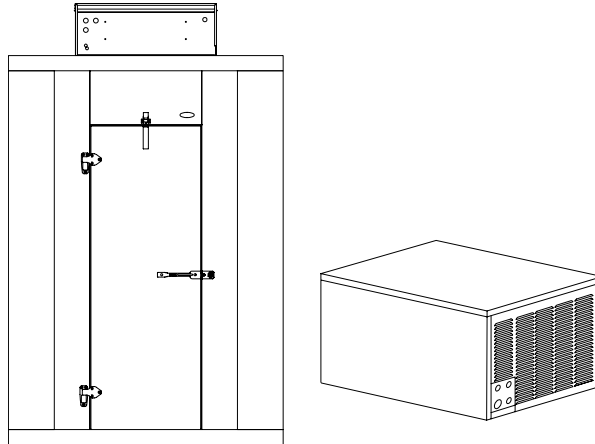

Optional Electric Condensate Vaporizer

Remote Capsule Pak Systems are available with an electric condensate vaporizer. This UL and C-UL approved product requires no drain lines on indoor applications, which makes installation fast and easy and allows equipment to be operational in a shorter time frame.